

---

# Lecture 11:

## Multipliers

Computer Systems Laboratory  
Stanford University  
horowitz@stanford.edu

Copyright © 2001 by Mark Horowitz

---

MAH/JZ

EE 371 Lecture 11

1

## Overview

- 
- Reading
  - Introduction
    - There are tons of papers written on multiplication. Unfortunately it is rare that the paper talks about the logic and circuit issues together. There are many 'logic' papers with describe clever ways of adding the partial products, but they rarely address the cost of the wiring. Other circuit papers talk about fast ways to build the basic adder cells. We will start with the multiplier organization, and look at both the logic and circuit issues.

---

MAH/JZ

EE 371 Lecture 11

2



# Main Issues

---

1. Create the partial products
  2. Sum them together
- For a fast multiplier
    - Reduce the number of partial products
    - Fast Adder cells
    - Tree adders
  - Talk about this stuff next

---

MAH/JZ

EE 371 Lecture 11

5

# Partial Product Generation

---

- In the simple form it is very easy:  
 $0 * A = 0$                        $1 * A = A$
- This is a simple AND gate at each bit
- But generate a PP for each multiplier bit
- We can generate a PP for every two multiplier bits
  - 0 0            0
  - 0 1            1\*
  - 1 0            2\* (this is easy to generate by a shift)
  - 1 1            3\* (yech -- but can make easy 4 -1, and delay the 4 into the next group)

---

MAH/JZ

EE 371 Lecture 11

6

# Modified Booth Coding

- Make it easy
  - When the MSB of the 2bits is 1 add 4 to next group up (2 = 4 -2)
  - Booth recoder looks at 3 bits
    - The two bits it is recoding, and the MSB of previous group

Table 1

MSB	LSB	Prev	Out
0	0	0	0
0	0	1	1
0	1	0	1
0	1	1	2
1	0	0	-2
1	0	1	-1
1	1	0	-1
1	1	1	0

# Booth Encoder

- For domino circuits
- Outputs are one hot
- Can be done in one 'gate'
- Need large output buffers to drive long wire to control all the mux that are connected to it.

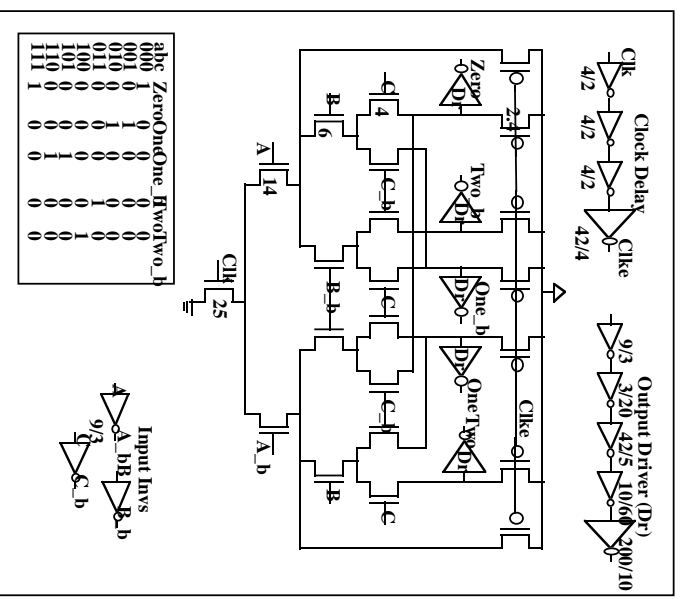

# Booth Mux

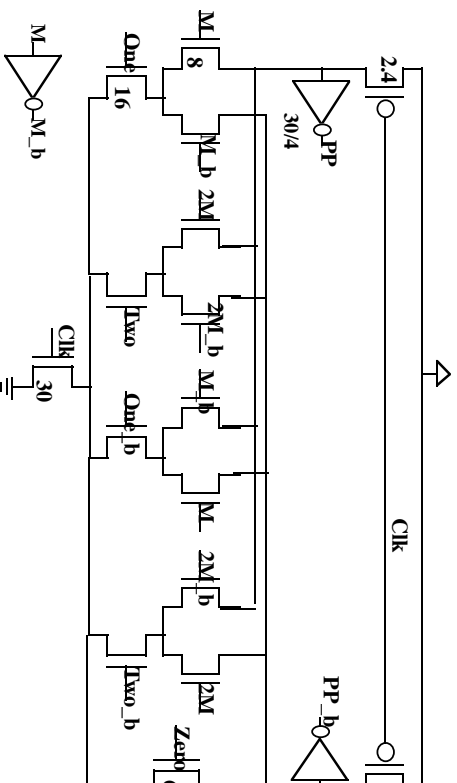

- Multiplicand is converted into dual rail partial products again by using local inverters, and is sent down to one significance higher booth mux, generating 2M.
- The adders get monotonic dual rail partial products from the booth mux.

MAH/JZ

EE 371 Lecture 11

9

# 3 Bit Booth

- Can recode 3 multiplier bits at a time
- Generates 1/3 of the partial products
- But you end up with needing 3\* Multiplicand
  - This takes an adder
  - So this is generally not done

Table 2

MSB		LSB	Out
0	0	0	0x
0	0	1	1x
0	1	0	2x
0	1	1	3x
1	0	0	-4x
1	0	1	-3x
1	1	0	-2x
1	1	1	-1x

Need to look at MSB of previous group and add 1 if it is 1. This still keeps the numbers between -4 and 4. The only hard one to generate is 3x

MAH/JZ

EE 371 Lecture 11

10

## Adding Partial Products

- If you want to add more partial products in a cycle you could use multiple adders
- This solution has two problems:
- Even fast adders are pretty slow
- 7+ FO4 delays
- Fast adders are pretty large
- Expensive in area

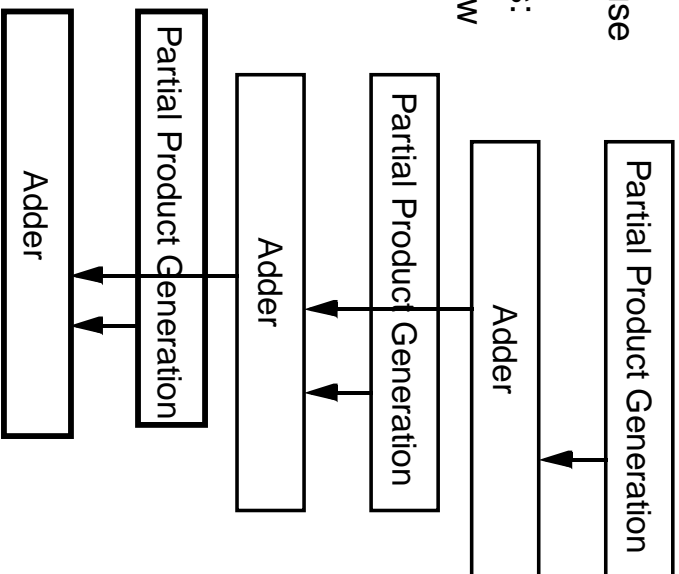

MAH/JZ

EE 371 Lecture 11

11

## Carry Save Adder

- To get a faster adder we will use a trick:
- Represent the result of adder (sum) in a redundant form
  - $\text{Sum} = \text{Sum}_1 + \text{Sum}_2$
  - That is when you add  $\text{Sum}_1$  and  $\text{Sum}_2$  together you get the right result. This is nice since we now don't need to propagate the carry in the adder.

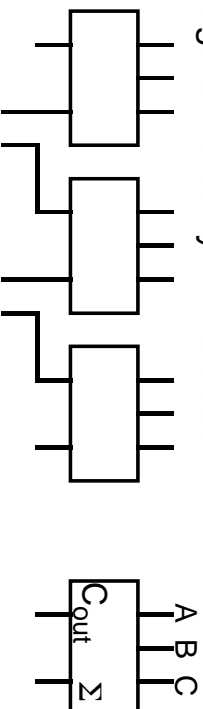

- Instead of rippling the carry, shift it left by one, and use it as the 'other' part of the sum. Each stage of the adder takes 3 inputs, and produces two outputs.

MAH/JZ

EE 371 Lecture 11

12

## Carry Save Adder

- Each adder can add one partial product to a redundant sum
  - Redundant sum takes two inputs, partial product takes the third
- Each adder is small and fast
  - Domino CSA is around 1.5 FO
  - CSA is pretty simple, it is just a full adder
- The problem is the output is really in an unusable form
  - At the end of the array you need to add two parts of redundant number together
  - This take a fast adder, but you only need one at the end of multiplier, not one for each partial product

MAH/JZ

EE 371 Lecture 11

13

## Multiplier Overview

- Block diagram of multiplier:

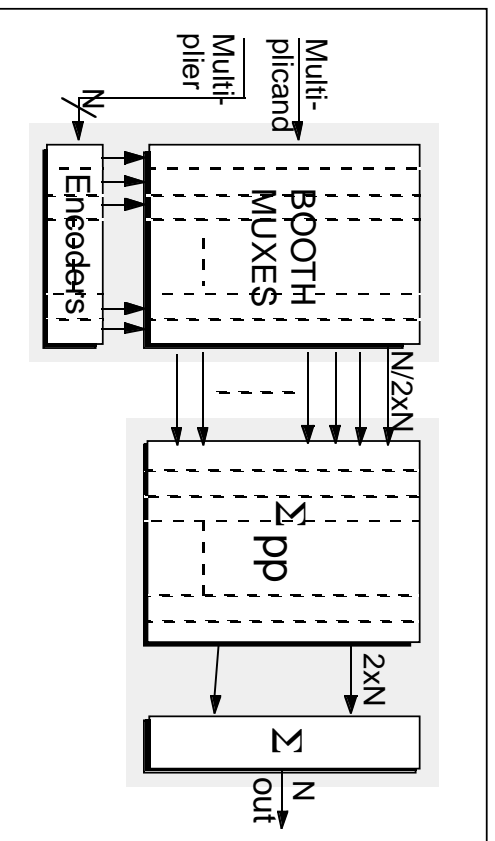

- The  $\Sigma$  array is in carry save adders, and final sum is a normal adder

MAH/JZ

EE 371 Lecture 11

14

# Array Multiplier

- For floating point numbers you have 53 bit numbers, which give 27PP

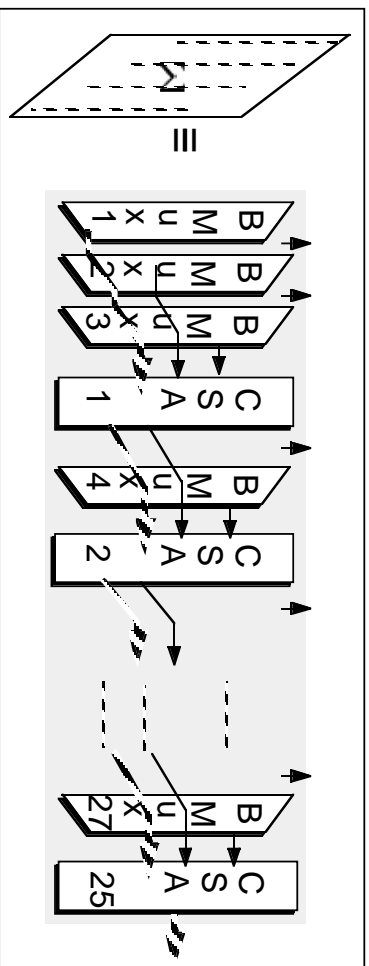

- 25 CSAs in datapath, all in critical path (First adder adds 3 PP)
- 56 bits tall regular datapath
- Short wires

MAH/JZ

EE 371 Lecture 11

15

# Tree Multipliers

- Can build faster  $\Sigma$  arrays but using tree adder



- Need to be careful since:
- Trees have longer wires (each adder is a row of adders)
- Drawn a binary tree, but CSA are 3 input 2 output devices
- Can build a 4:2 combiner using 2 CSA

MAH/JZ

EE 371 Lecture 11

16

## 4-2 Adder

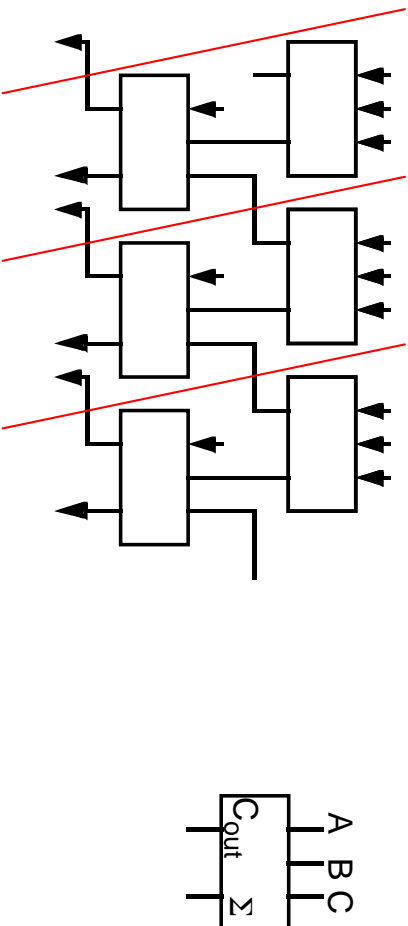

- If you ignore the side branches you get 4 inputs in each bit position, and two output at each bit position. This allows you to build binary trees. You can build 3:2 trees, Wallace Trees, (and it is a little faster) but the wiring is much more complex

## Tree Layout

- Full (4:2) Trees:

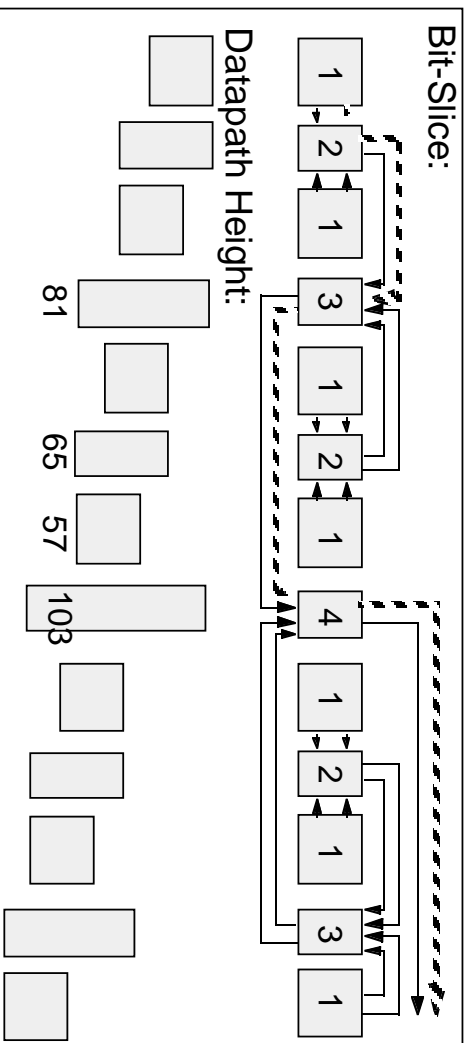

- 26 CSAs in datapath, 8 in critical path
- Increased datapath height
- Long wires, many cross-overs, wiring channels

# Interleaved Arrays

- Compromise solution

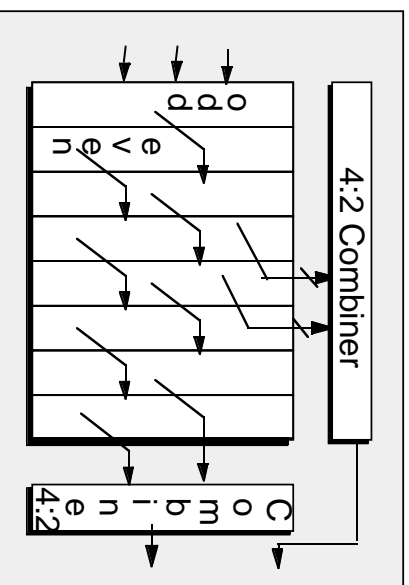

- Full-array critical path reduced by half for small area overhead
- Longer wires within the array
- Can we do even better?

# Array-of-Arrays

General Idea:

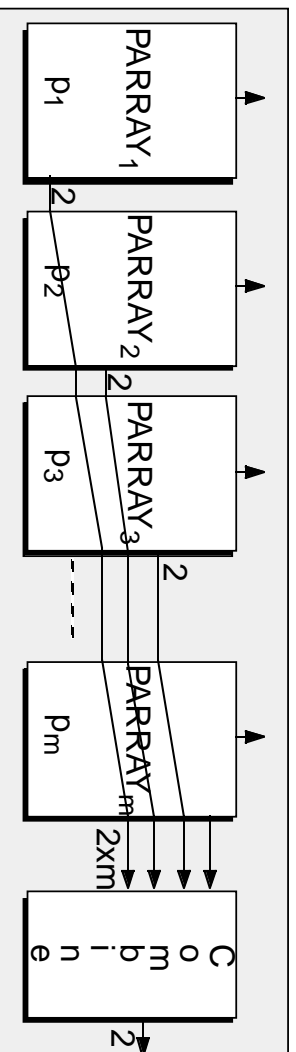

- More partial arrays: higher parallelism, wiring complexity, larger combining network
- Chose M depending on problem size

## Two Partial Arrays

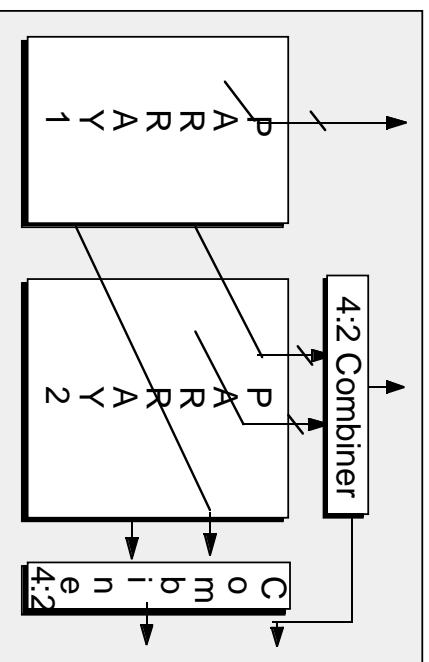

- Regular wiring, small number of cross-overs
- Maximum effective wire loading  $\sim 1.5 \times \text{CSA delays}$
- For optimal parallelism,  $p1=13 + p2=14$ .
- $\sim 14.5$  CSA delays in critical path

MAH/JZ

EE 371 Lecture 11

21

## Four Partial Arrays

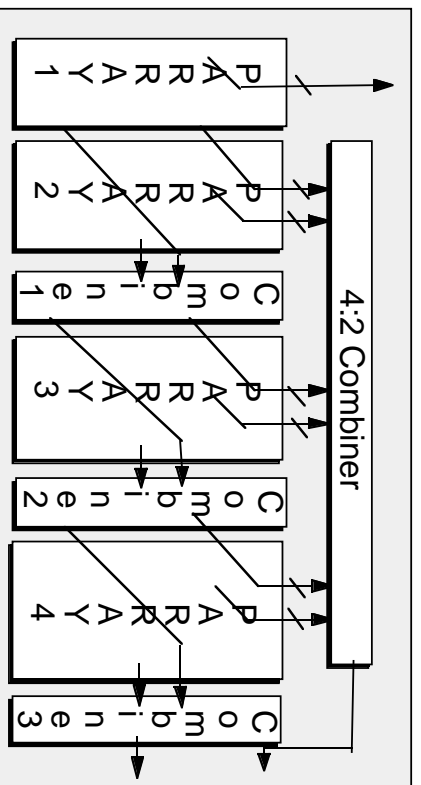

- Tree combiner: Wiring, area overhead
- Matching Array Delays:  $5+5+7+10$  pp.10 CSAs
- Optimal Parallelism:  $4+4+8+11$  pp. 11 CSAs
- More Partial arrays?: marginal returns

MAH/JZ

EE 371 Lecture 11

22

## Details

- There are two details that we still need to cover
  - Dealing with the bits that fall off the end of the array
  - In the array organization the datapath width remain constant
    - The ‘extra’ (LSB) bits fall off the top of the array
    - But these bits are still in redundant form
    - For rounding these bits need to be added too
  - Dealing with negative partial products
    - The problem is with sign extension
    - Need to extend the sign bits the full  $2N$  bits
      - This is  $N$  additional bits for the first PP

- Look at these issues next

MAH/JZ

EE 371 Lecture 11

23

## LSBs Falling Off the Array

- Speed through the array is one CSA delay

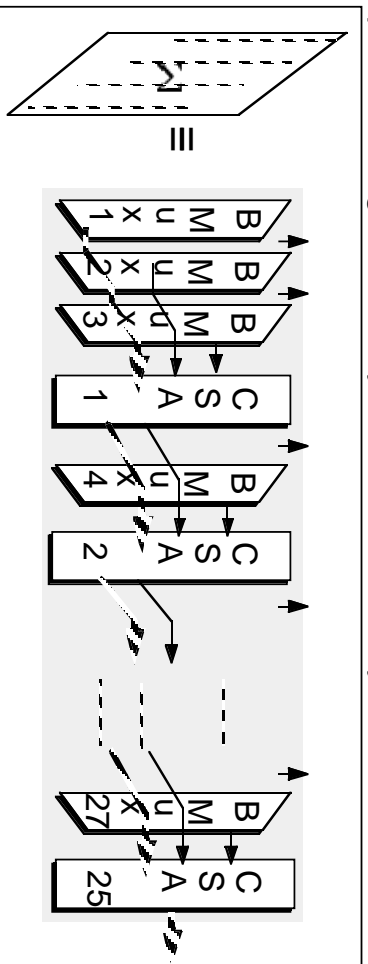

- But since the PP are booth coded, two bit positions fall off each stage
- Need to do a two bit carry propagate add in on CSA delay
- Build a small carry select adder
- Carry in to carry out is only a mux delay

MAH/JZ

EE 371 Lecture 11

24

## Faster Structures

- Do more adds in parallel, making dealing with the end bits harder
  - In tree adder, all the bits fall off the end at roughly the same time
  - Array of arrays has a similar problem
    - Need to build a complete carry propagate adder for these bits

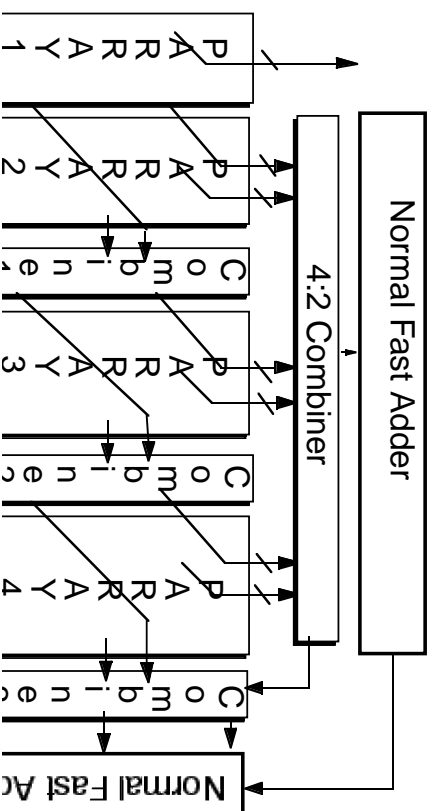

MAH/JZ

EE 371 Lecture 11

25

Courtesy D. Foley

## Sign Extension

- When the PP is negative, need to sign extend
  - This is bad since the fanout can be large
- Use a trick instead
  - Pre-add the triangle of 1's
 
$$\begin{array}{r} 11111111 \\ 11111111 \\ 11111111 \\ 11111111 \\ 11 \\ \hline 10101011 \end{array}$$
  - To clear out 1's add 1 to the row
 
$$\begin{array}{r} 11111111 \\ \hline 10101011 \end{array}$$

MAH/JZ

EE 371 Lecture 11

26

