Lecture 3

Transistor Models

Mark Horowitz
Computer Systems Laboratory
Stanford University
horowitz@stanford.edu

Copyright © 2002 by Mark Horowitz

Overview

Reading

Chen	Predicting CMOS Speed
Pelgrom	Transistor Matching
Lovett	Transistor Matching

Introduction

Transistors are not all the same, we need to have some model of the variations too. This comes both in local variations (matching), and run to run variations. In this lecture we will briefly review the transistor models, and spend most of the lecture talking about device variations.

There is also a struggle in doing simulations: on the one hand you would like the model to be accurate, and yet you need to understand the model to be able to reason about it and predict the results. This leads to a number of strategies of building simple models first and then building up the complete model. To do this it is helpful to 'calibrate' a technology, and use these simple models to help you reason about the technology, and circuit.

MOS Device Behavior

Assume you know MOS device issues from EE313

- Briefly review what the most important issues are:
 - Break into iV and CV curves
- Glasser (and most other books) covers this material in more detail if you want more info.

For iV curves need to understand:

basic shape, threshold voltage, mobility effects, velocity saturation, subthreshold leakage, scaling (and variations in these parameters)

For CV curves need to understand:

overlap capacitance, channel charge, junction capacitance

Basic Shape

Two plots are used, one vs. V_{ds} , and one vs. V_{gs}

- I_{ds} - V_{ds} plot
 - Two regions
 - Linear (low V_{ds})
 - Saturated (high V_{ds})
 - Linear region
 - Effective Resistance
 - Saturated region
 - Current
 - G_m
 - G_{ds}

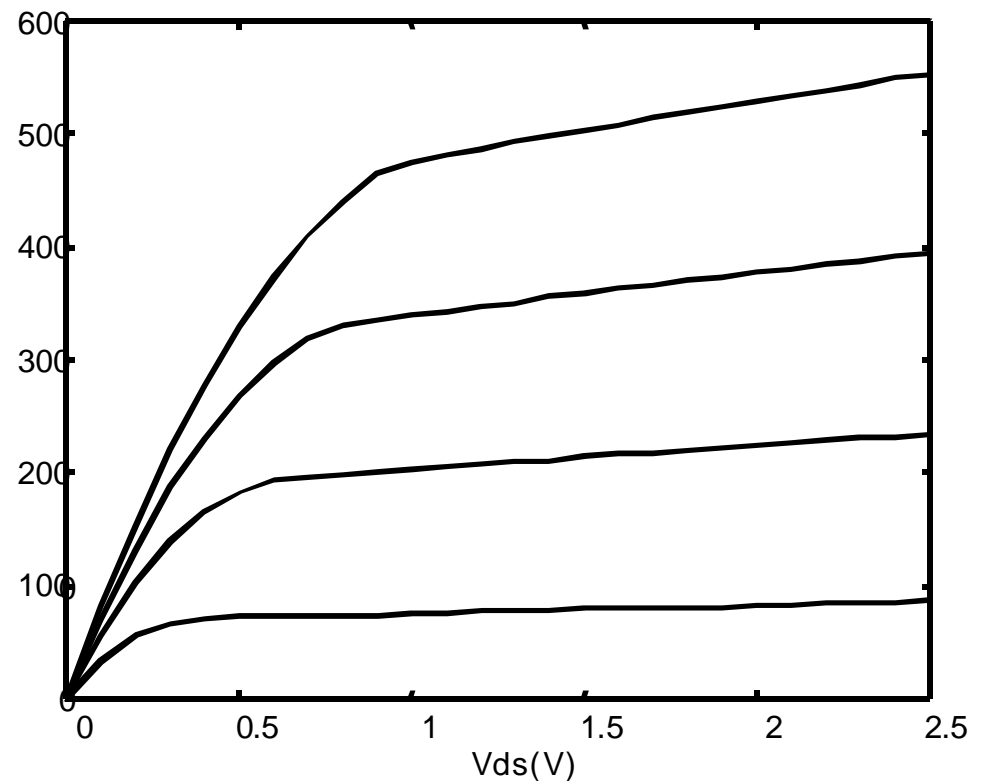

Basic Shape

I_{ds} vs. V_{gs}

–Two regions again

- Subthreshold
- Saturation

–Subthreshold

- Slope of line
- Threshold voltage

–Saturation

- Current
- G_m

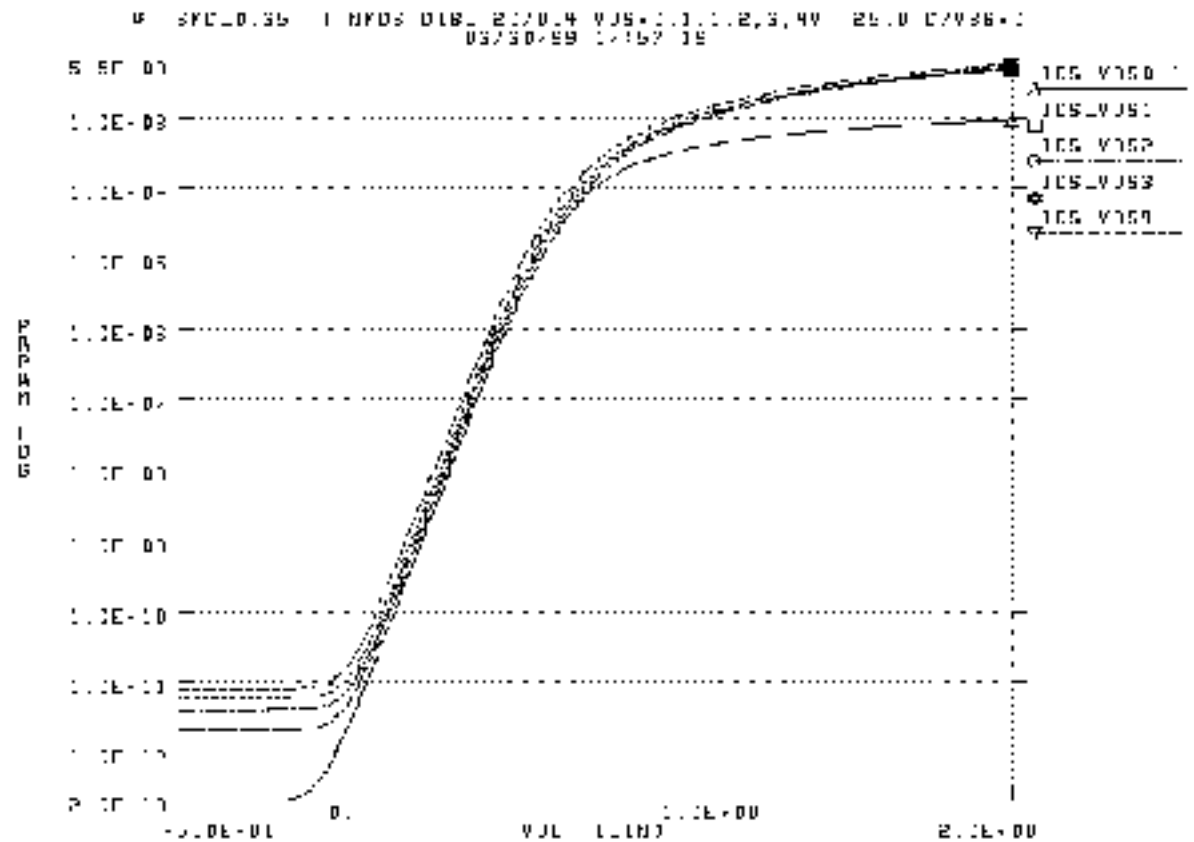

Mobility

Has a strong temperature dependence:

$$\mu = \mu_o \left(\frac{T}{T_o} \right)^{-3/2}$$

Temp change from 27o to 130o decreases current to 0.65. The circuit will run 1.6 time slower.

Also decreases with high vertical field, and channel doping

- New models say it is completely set by vertical field

$$\mu_e(V_{gs}, V_{th}, T_{ox}) = \frac{540}{1 + \left(\frac{V_{gs} + V_{th}}{0.54T_{ox}} \right)^{1.85}}$$

μ in cm^2/Vsec , T_{ox} in nm

Velocity Saturation

Mobility, μ , relates carrier velocity to electric field,

Relationship is not linear, max velocity is around 8×10^6 cm/s

Approx i_{dsat}

$$i_{dsat} = \frac{W v_{sat} C_{ox} (V_{gs} - V_{th})^2}{V_{gs} - V_{th} + \frac{2 v_{sat} L}{\mu_{eff}}}$$

Equation works in both limits.

When completely velocity saturated:

$i_{ds} = W C_{ox} (V_{gs} - V_{th}) v_{max}$
which is independent of L

i_{ds} for a 0.35μ technology

v_{max} L term around 2.3V

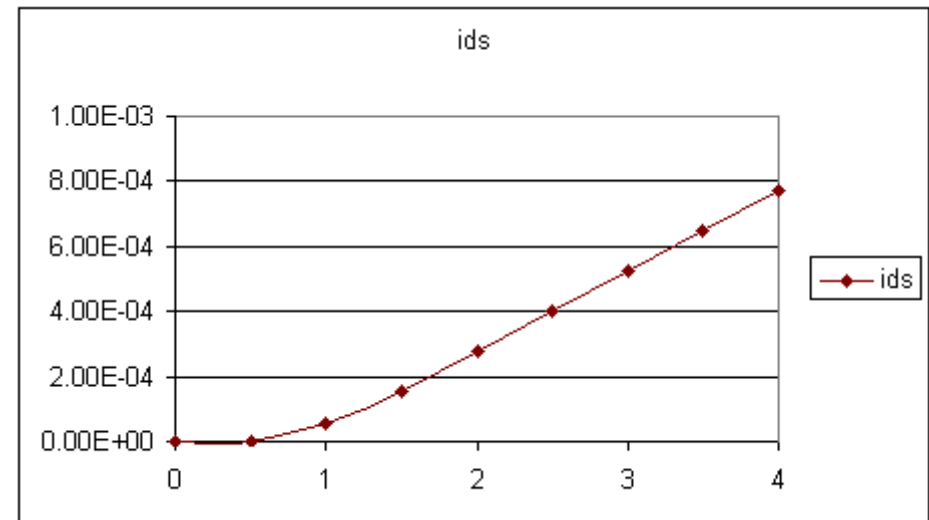

Subthreshold Conduction

The threshold voltage is not a magic place

- Voltage where the channel charge is roughly equal to the doping
- Have channel charge when V_{gs} less than V_{th}

Feedback is not as strong

Gate directly controls Φ_s , not channel charge

Channel charge exponentially related to Φ_s

$$I_{ds} = I_s \times e^{\frac{V_{gs} - V_{th}}{\alpha V_t}}$$

$V_t = kT/q = 26\text{mV @RT}$

I_s depends on definition of V_{th} , around $0.3\mu\text{A}/\mu$

α is from cap voltage divider, around 1.3

MOS Capacitance

There is a lot more to worry about than channel capacitance

For 0.25 μ m technology, 5nm gate oxide

- $C_{ox} = 6.9 \text{ fF}/\mu^2 = 1.7 \text{ fF}/\mu$ width
- Gate overlap cap $\sim 0.2 \text{ fF}/\mu$ (per edge)
- Diffusion cap
 - 1.0 fF/μ^2 bottom plate
 - 0.3 fF/μ sidewall
- Total

$$C_{\text{gate}} = 1.7 W$$

$$C_{\text{overlap}} = 0.4 W$$

$$C_{\text{bot}} = 0.7W$$

$$C_{\text{side}} = 0.6W + .4$$

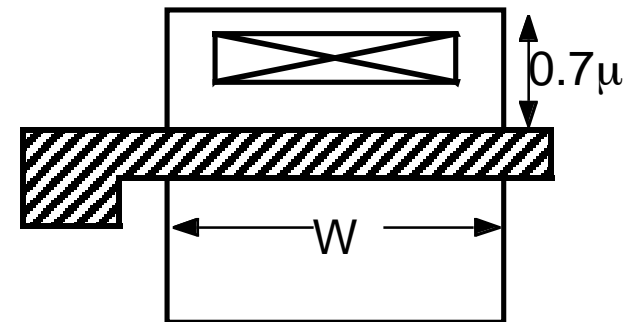

MOS Scaling

With high fields, quadratic model is not very accurate for estimating scaling effects. A better model is:

$$I_{\text{dsat}} = K W L_{\text{eff}}^{-0.5} T_{\text{ox}}^{-0.8} (V_{\text{gs}} - V_{\text{th}})^{1.25}$$

If L, T_{ox}, V all scale (note V scaling will be limited by V_{th} scaling)

- Current should remain constant per micron.
 - It will be 0.6 to 0.8mA/ μ
 - Current for a scaled transistor scales down by α
 - Voltage scaled down by α
 - Capacitance scales down by α
- $\forall \Delta t = CV/i = \alpha \Delta t$
- This assumes that V_{th} continues to scale, and this is not likely to happen

Parameter Variations

Talking about transistors like all transistors are the same

Not true -- no two are exactly the same

Parameters of a fabrication run are generally normally distributed

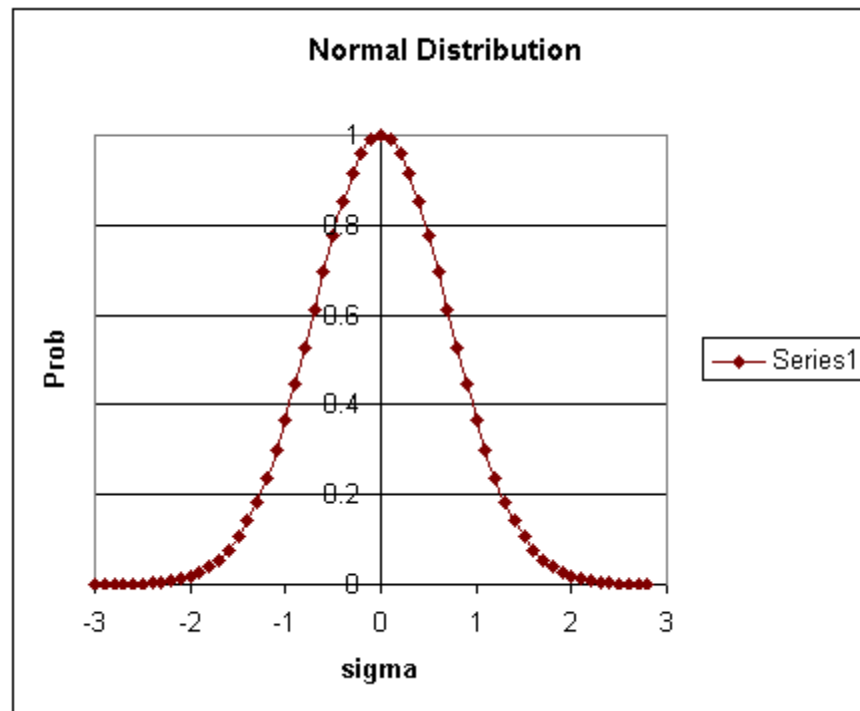

Variations

There are really many parameters:

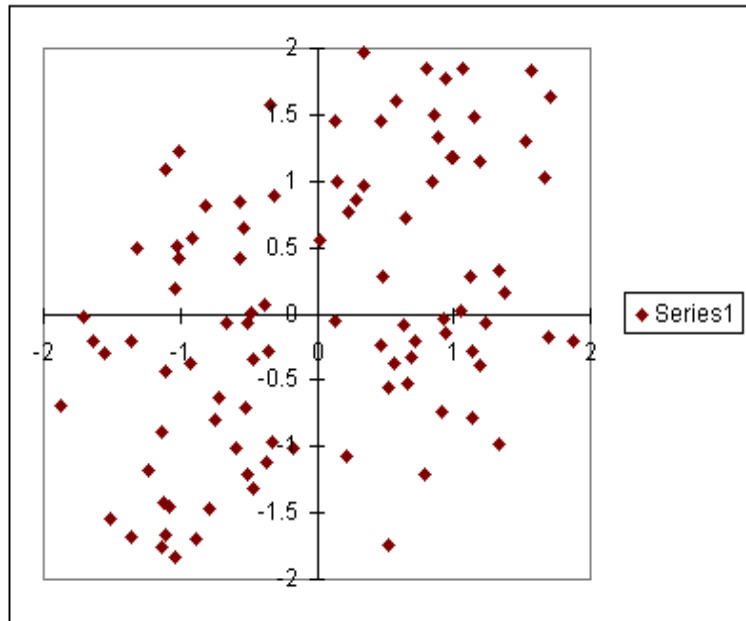
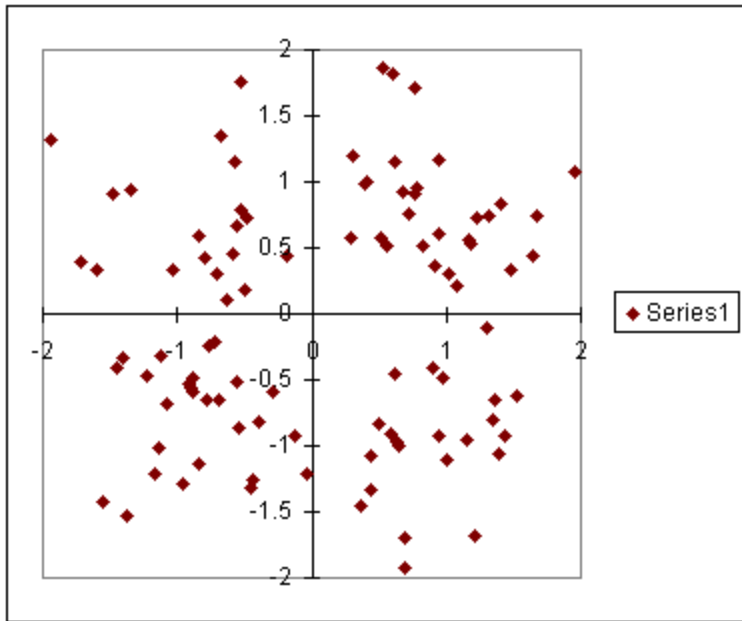

Sometimes they are correlated, and sometimes they aren't

Corners are the extreme points on the distributions

For correlated parameters corners are pessimistic

Process Corners

Extreme points in parameter distributions (spec limits)

- Probably stress circuits at these points
- Good place to test your design

Corners:

Process parameters:

Poly linewidth, nMOS V_t , pMOS V_t , T_{ox} ,
metal width, oxide thickness

Operating conditions

Temp (0-100 die temp)

Operating voltage (die voltage)

EE371 Corners

Group parameters into transistor, and operating effects

nMOS can be slow, typ, fast

pMOS can be slow, typ, fast

Vdd can be high, low

Temp can be hot, cold

Use library file to get models

- This file sets up the temp, device models parasitics and voltage
- file is `/usr/class/ee371/lib/opConditions.lib`
- Contains the following conditions

Library

Label is nMOS, pMOS, Temp, Voltage

TTTT = typ nMOS, typ pMOS, room temp, nominal supply

SSSS = slow nMOS, slow pMOS, hot temp, low supply

FSSS = fast nMOS, slow pMOS, hot temp, low supply

Note that wires are not included. We will either provide a separate wire model, or you will have to create your own.

The temp and voltages are the levels that the die sees, and this is worse than the package spec.

w.c. temp 110°C, w.c. voltage +10%, -15%

What To Look For

- TTSS Must meet timing specification for part
 - SSSS Sometime need to hit spec here too, signal collapse
 - FFFF Power issues, edge rates on IO outputs, pulse collapse
 - SFSS Failure of ratio circuit, race conditions
 - FSSS Failure of ratio circuits, race conditions
- etc.

Style, cont'd

To use library file:

```
.lib '/usr/class/ee371/lib/opConditions.lib' SSSS
```

- This calls out the set of models for the slow simulation case
- Could have used any of the others.

```
.lib '/usr/class/ee371/lib/opConditions.lib' TTSS
```

Can use `.alter` command to run simulation in many cases

- Device models are always `nmos`, `pmos`

```
Mname      drain gate source substrate nmos
```

```
Mname      drain gate source substrate pmos
```

Philosophical Struggle

How to analyze circuits?

- Use your intuition and your pencil and paper analysis. These are things that you understand. SPICE is prone to Garbage In / Very Pretty Garbage Out. Need to understand circuit to check SPICE, and not vice versa.
- There is enormous complexity and ugly nonlinearity in VLSI circuitry, making it potentially very difficult to do hand analysis. Also competitive market pressure requires sophisticated circuitry (which need SPICE) on short schedules or you will be steam rolled by your competitors

So you end up doing both

Calibrating a Technology

When you get a set of models for a technology, it is a good idea to run some simple simulations to get a feeling for the technology. Here are some things that I like to run:

- Run iV curves for a few device sizes.

Do the curves seem reasonable?

What do they say about:

velocity saturation, output conduction, V_{bb} sensitivity

subthreshold conduction, V_{th} effects (DIBL, $DV_{th}(W,L)$)

To get a feeling for these effects, you will need to do a few simulations:

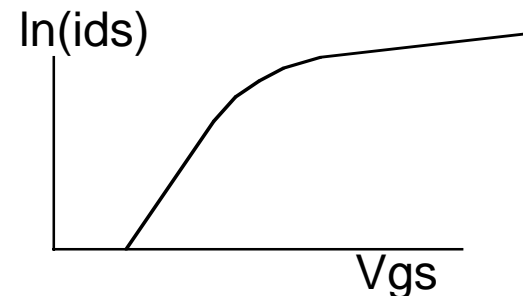
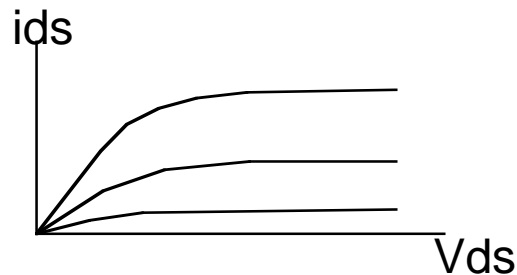

Ids vs. Vds

Look at different channel lengths (nMOS):

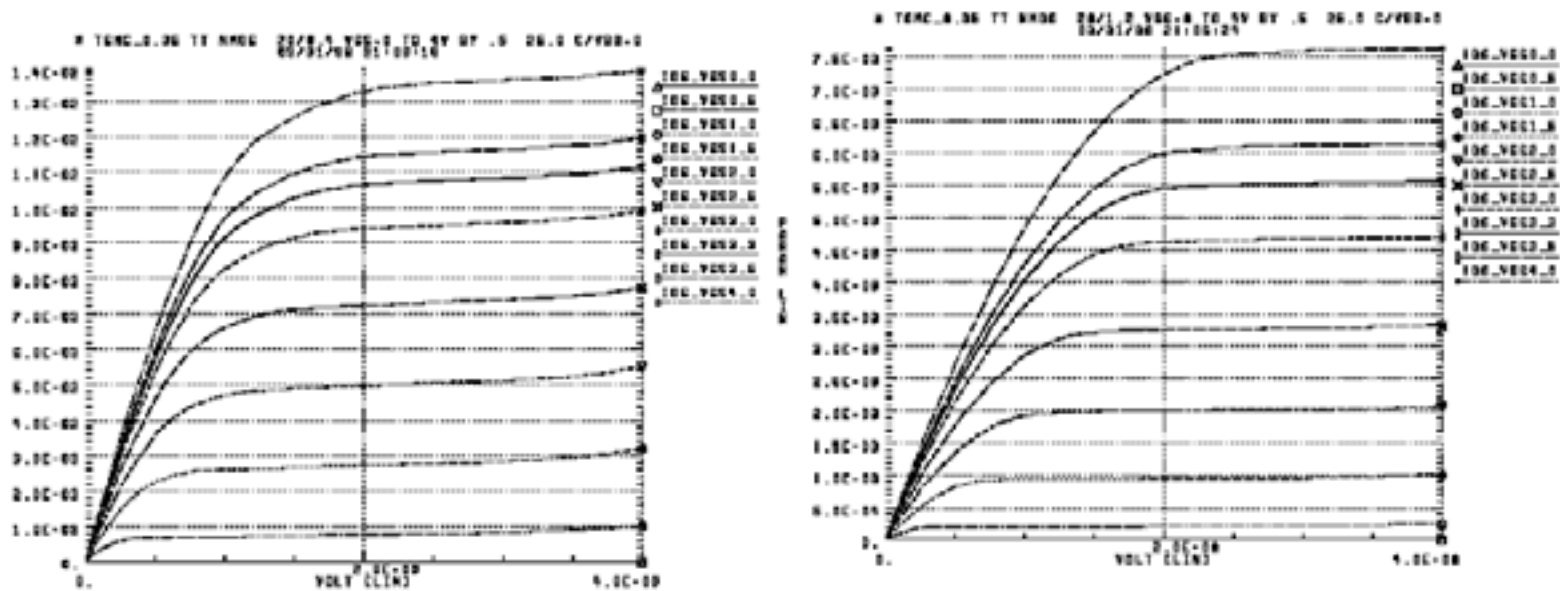

- Notice:
 - Difference in output slope
 - Linear gm in longer channel device

Ids vs. Vds

Look at different channel lengths (pMOS):

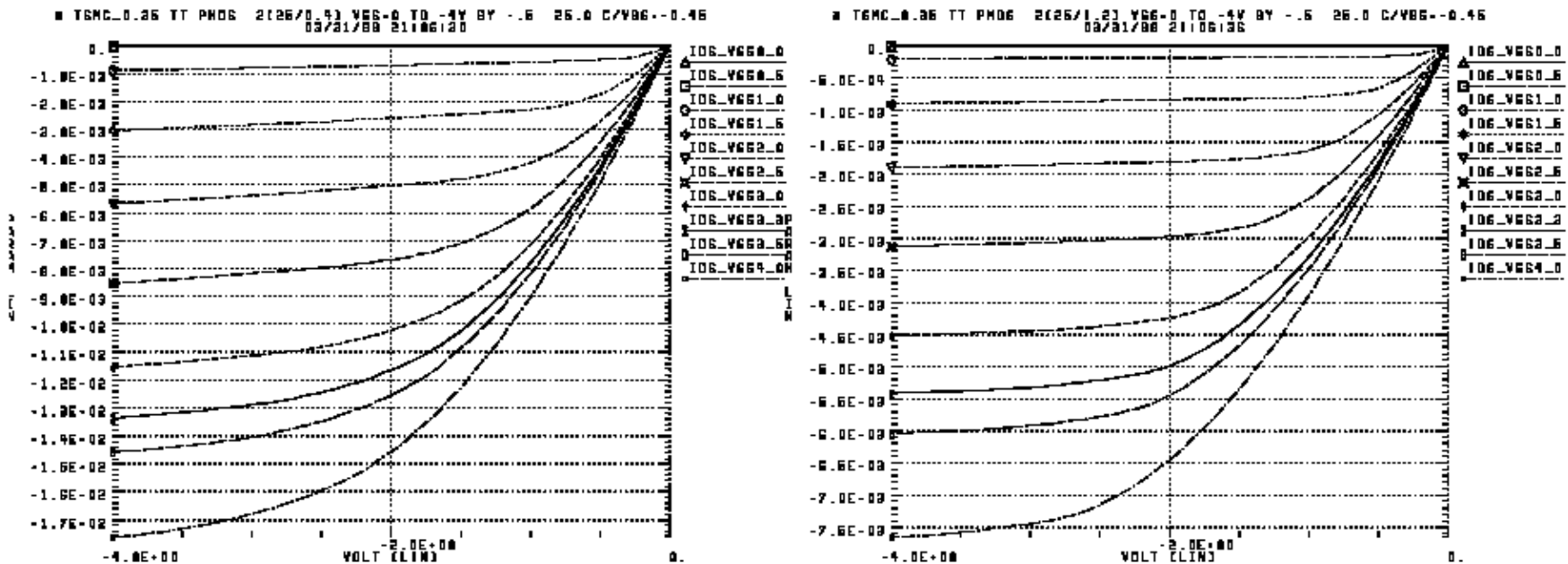

- Notice:
 - Difference in saturation voltage from nMOS
 - Linear gm in longer channel device, change in output slope

Ids vs. Vgs (nMOS)

Look at

Vds

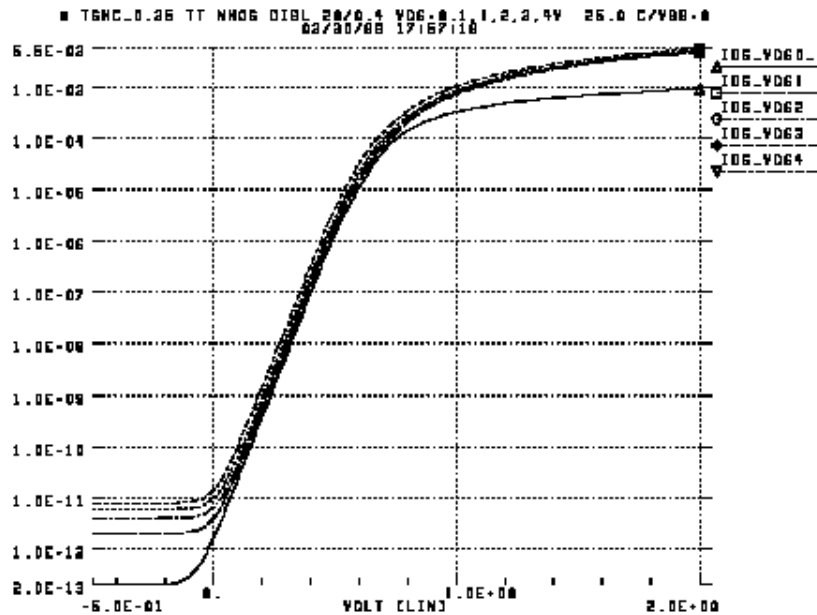

Vbs:

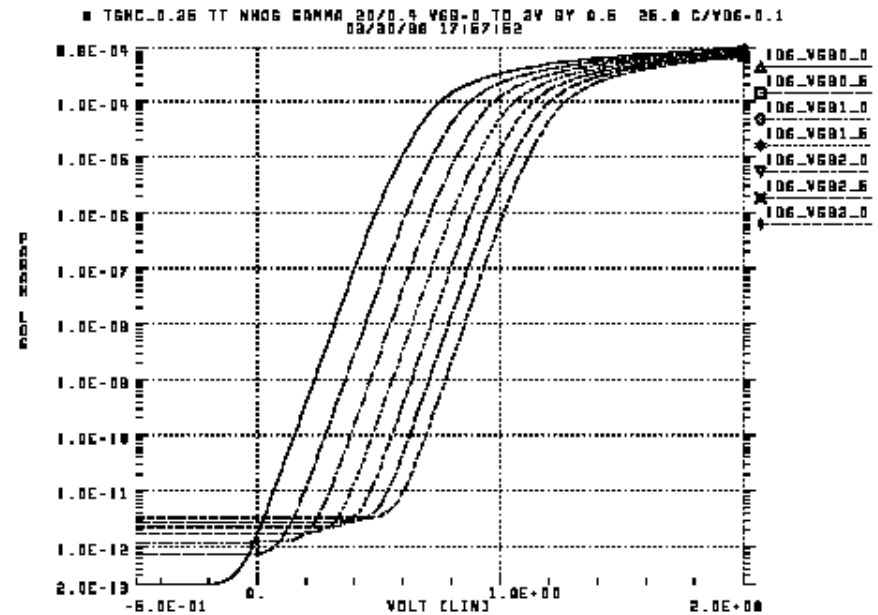

- One shows DIBL, and the other shows gamma:
 - DIBL is drain induced barrier lowering, it is when the voltage at the drain reduces the threshold voltage

Ids vs. Vgs (pMOS)

Vds

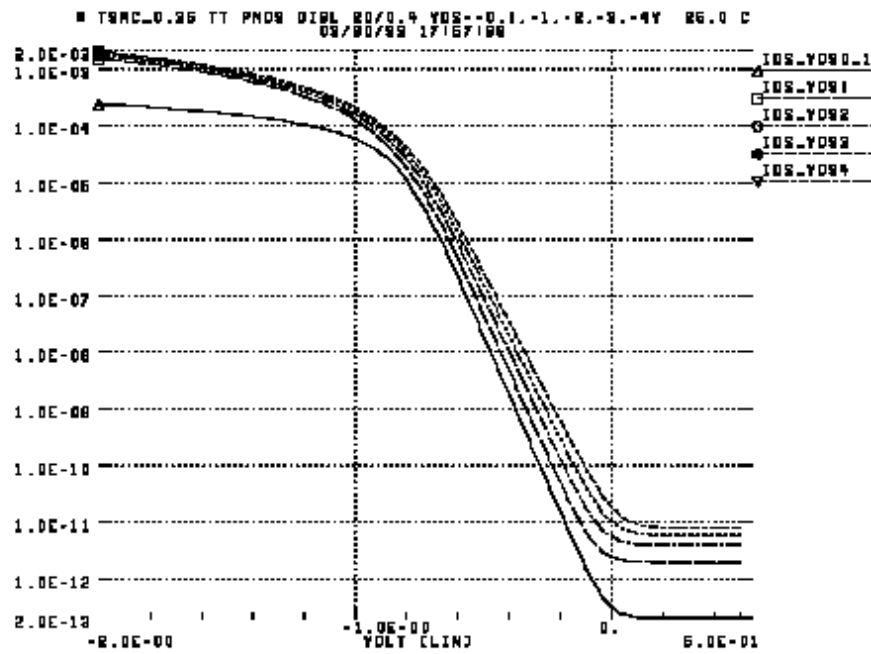

Vbs:

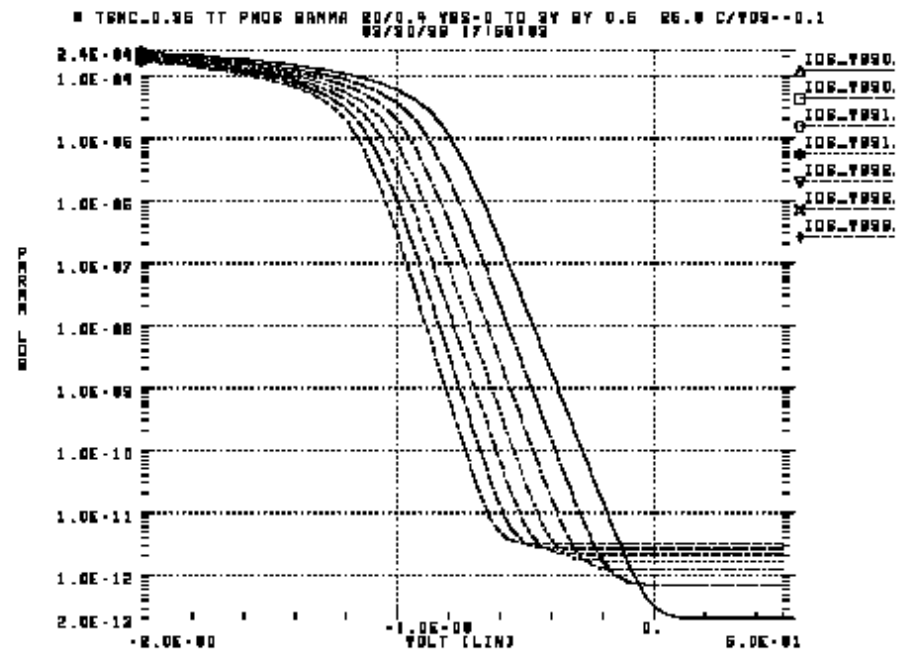

Gds vs. L

nMOS

pMOS

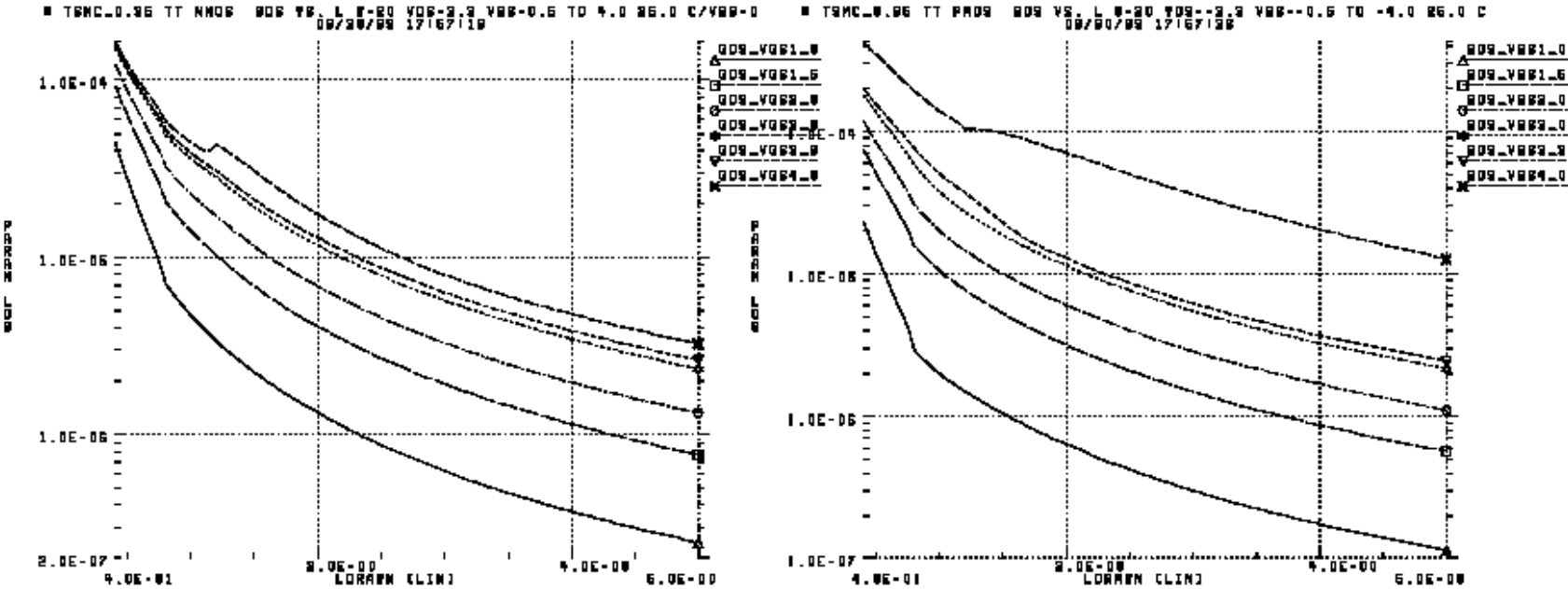

Threshold Voltage nMOS

Notice change with temp, channel length, width:

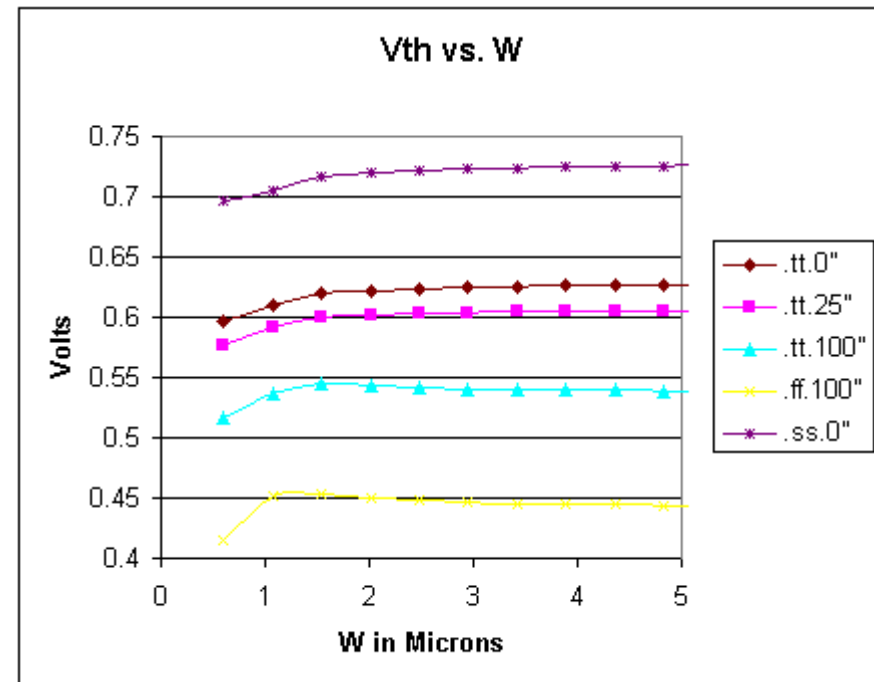
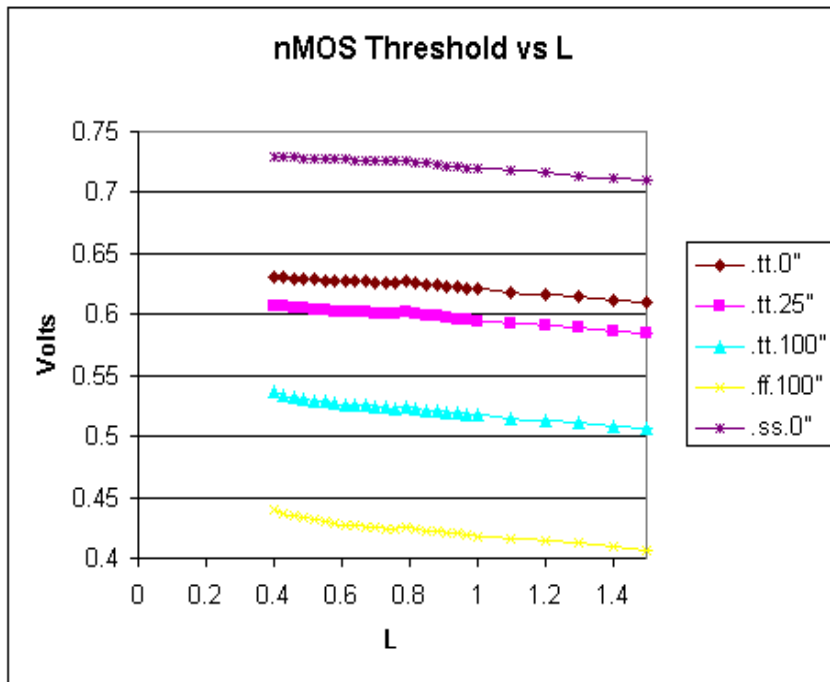

Threshold Voltage pMOS

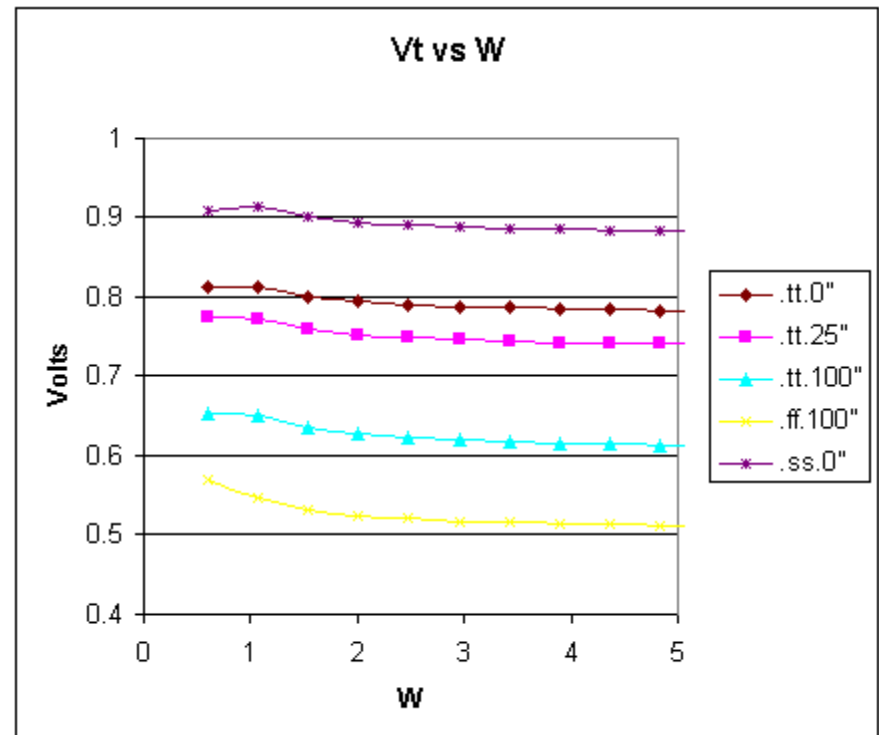
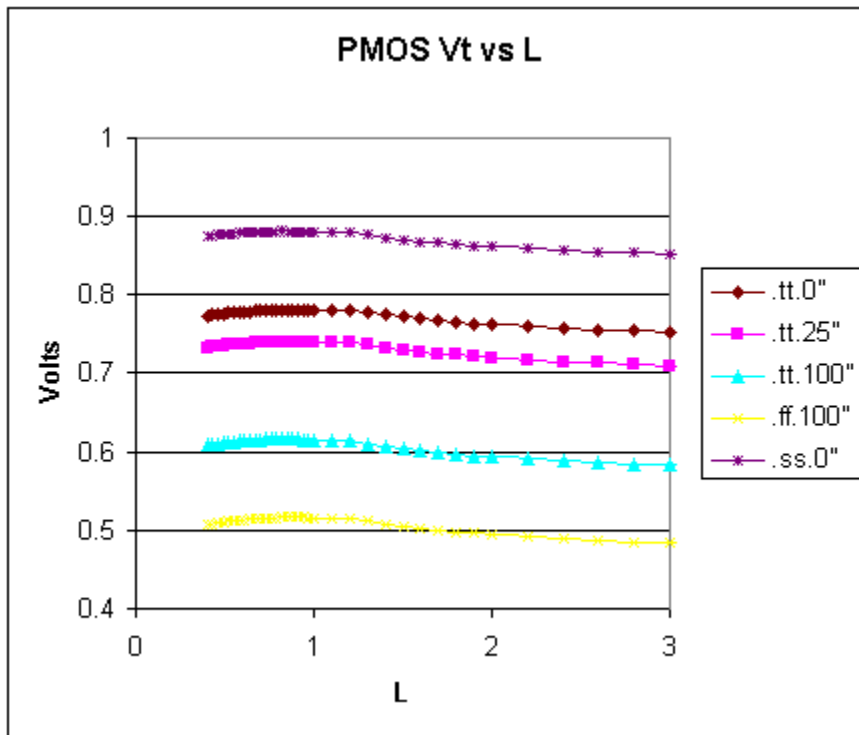

Calibration, cont'd

We like our RC model, so we need to figure out what R and C are

- Gate Capacitance -- fF/ μ

Used for two reasons, delay and power, and they are not the same

How does it depend on input slope, output slope, temp, V

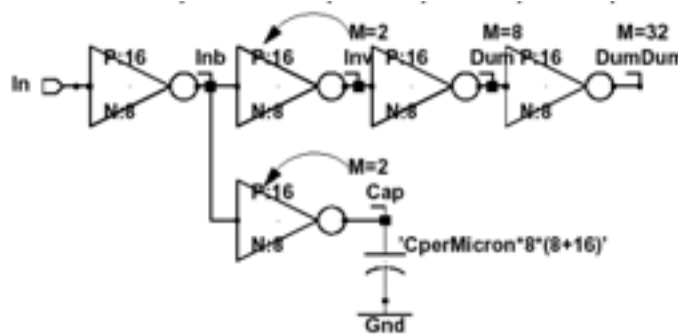

Why have so many gates?
M=8 gate is the one we are
trying to match. 1x is to
make input to 2 2x nominal.

Find C so the delay of 4x gate is the same in both paths

Can change pre/post gate to change input/output slope

Calibration, cont'd

Gate cap for power:

- Many options, and a little tricky
- If you measure current pulled by M=2 gate, $I(V_{dd})$
 - Includes short circuit current
 - Includes parasitic cap current
diodes, and gate overlap on M=2 gate!
- Measure the current going into M=8 gate
 - Add 0V voltage source between driver and gate
 $C = i/V_f$
 - I think this is the 'right' answer

Calibration, cont'd

Resistance of a transistor -- Ω_{μ}/W

Know gate effective cap, so $R = \Delta T/C$

How does R vary with Temp, input slope, V

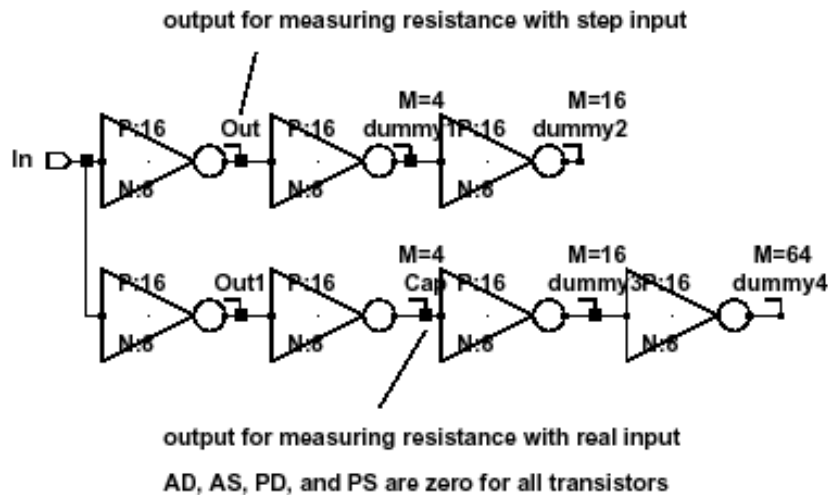

What for parasitic capacitance changing your measurement.

Since can't remove some parasitics, measure resistances will large load caps (large FO)

- How do R's add (two transistors in series)?
replace inverter with enable tristate inverter, but watch parasitic cap

Calibration, cont'd

Effective capacitance of transistor parasitics -- fF/μ or fF/μ^2

- Gate overlap, diffusion edge, area
 - Replace M=8 inverter with diode model
gate width, PS, AS control these parasitics
W, AS=0, PS=0 give gate overlap
W=0.4 μ m, AS= PS=0 might not give area component
If model has series resistance, it might effect measurement
 - For diffusion cap C for rising and falling transitions are different!

Wire parameters

- Cap fF/μ , ratio to gate cap
- Coupling
- Resistance, RC product

Now What?

Use your simple models to reason about circuit

- Look at different trade-offs
- Try to determine what is important
- If you need more information, do some sims to build new model
- Come up with 'good' first pass design

And then simulate it!

- First look at a few of the corners that might be interesting
- See if the results make sense
 - If not, check the circuit schematics
 - Check you models (where does it break down -- learn)
- Check it over many corners

Simulation Issues

Conflict:

- Simulation is cheap, silicon revs are VERY expensive
 - Don't scrimp when you construct a SPICE deck
 - Simulate the real stuff under real conditions
 - Include the real input waveform and load devices
- The more complex the deck, the more confusing the results
- will be
 - Easier to make mistakes in entry
 - Simulating the wrong thing
 - Interaction of lots of small mistakes
 - Hard to debug
 - Slow simulations / long revision times

Compromise

Start simple, and then add complexity

- Start with an understandable and predictable simulation deck
- Add more complexity, and check at each step that the results make sense
- End up with complete simulation file

Need to remember to add all the effects you need to model

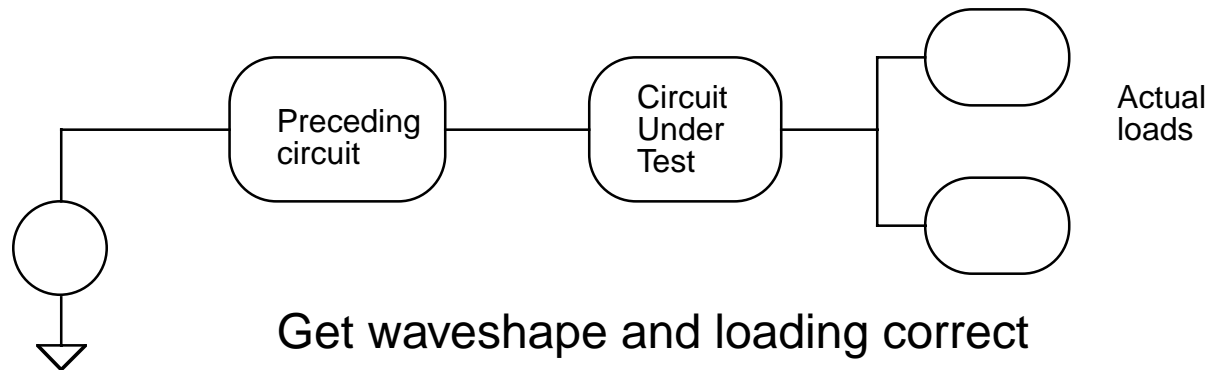

Matching

If you want two transistors to match you need to be very careful
Almost anything will make them different
In SPICE all transistors match perfectly,
You need to add mismatch explicitly to model problem

Things you need to avoid:

X, Y in silicon are not exact the same.

Match -> orient them the same way

Is this ok?

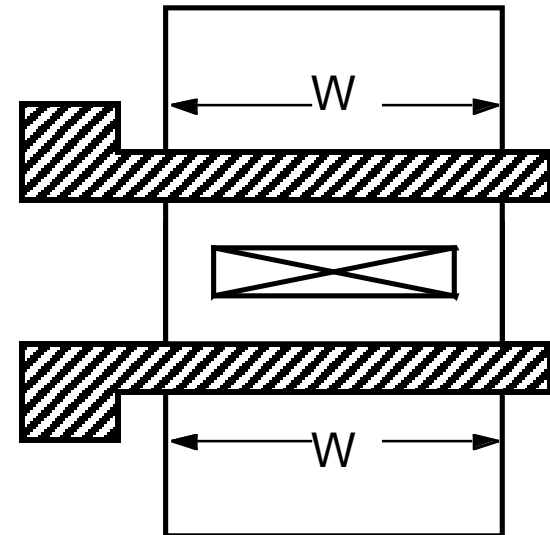
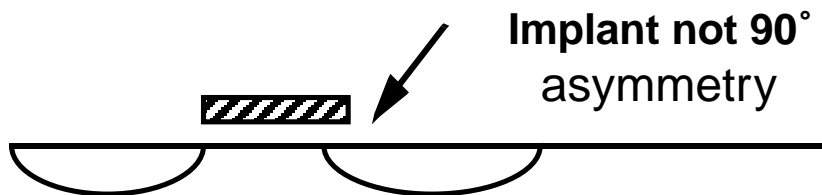

Matching

Need to worry about poly alignment

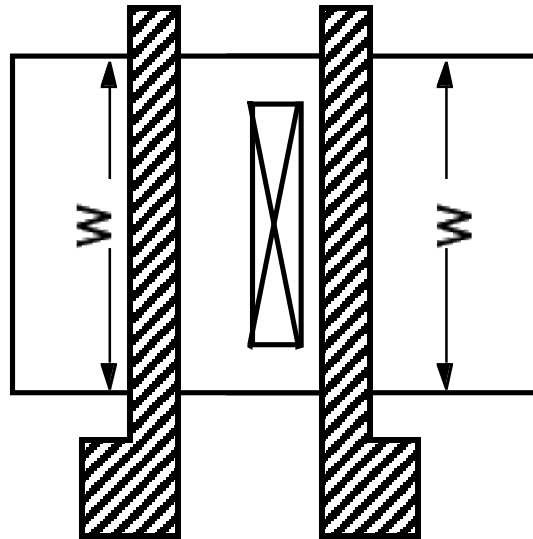

In this case diffusion resistance, and cap will not match

Solution:

Make sure current flow in the same direction in matched transistors

Easy if all the transistors are folded

Matching

Poly width needs to be carefully controlled

- Etch rate depends slightly on the local density of poly
- To match transistors local poly density needs to be the same.

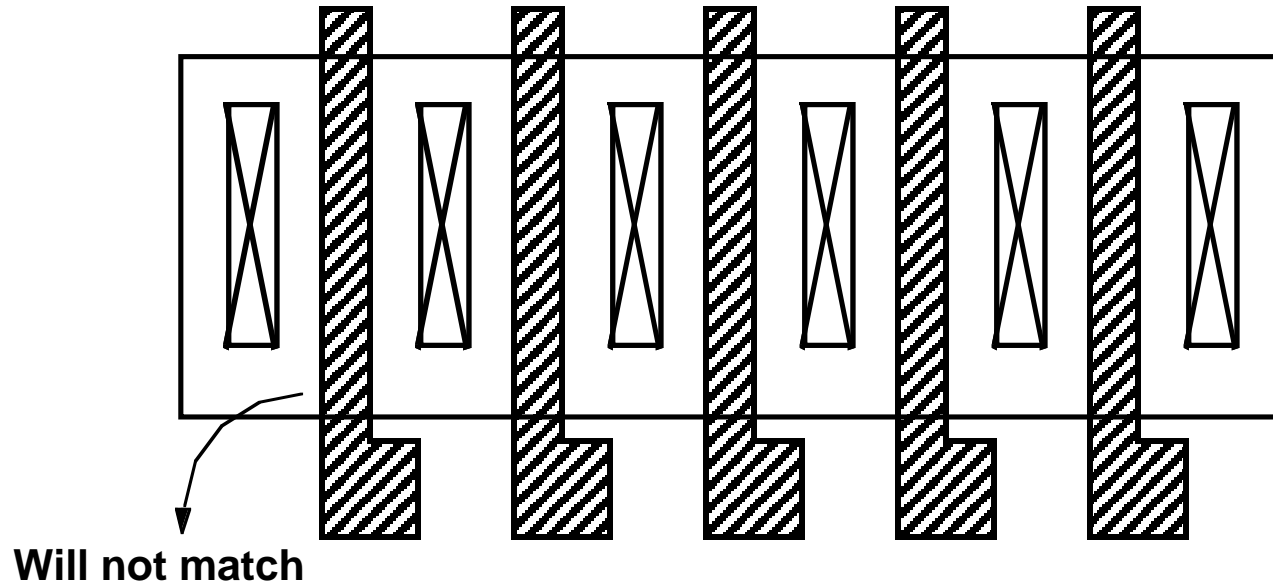

End transistors will be different, next to end might be effected too

Statistical Matching

Even when you do everything right, there are still random errors:

V_{th} errors

Current matching

Data indicates that the matching depends on the $\sqrt{L_{\text{eff}}W_{\text{eff}}}$

$$\sigma(V_{\text{th}}) = 0.6V^*T_{\text{ox}}/\sqrt{L_{\text{eff}}W_{\text{eff}}}$$

Need to measure T_{ox} and L, W in same units

$$\sigma(I_{\text{ds}}) = 2\% \mu / \sqrt{L_{\text{eff}}W_{\text{eff}}}$$