

3G EVOLUTION – AN OVERVIEW OF LTE FOR MOBILE BROADBAND

JAMES KEMPF*

RESEARCH AREA PACKET TECHNOLOGIES

ERICSSON RESEARCH

MAY 11, 2010

with thanks to Dr. Stefan Parkvall, Ericsson Research



MOBILE BROADBAND

Om du har en bärbar dator,
**varför har du
 fast bredband?**

Surfa trådlöst i hastigheter upp till 7.2 Mbit/s



mobil Sveriges
 Bästa
 3G-nät

3Bredband 3Bredband 3Bredband

- Sweden's sales Top 10
 for September 2007
- 1 **HSPA USB Modem**
 - 2 ...
 - 3 Sony Ericsson K530i
 - 4 ...
 - 5 Sony Ericsson T650i Blue
 - 6 Sony Ericsson W660i RoseRed
 - 7 ...
 - 8 Sony Ericsson W880i Black/Red
 - 9 Sony Ericsson W880i Silver/Black
 - 10 **HSPA DataCard**



HSPA

Turbo-3G

LTE

Kids who surf faster
 see more,
 learn more,
 do more.

maxis.broadband



Maxis Broadband

3Data.

Surfen ohne Ende -
 für Power User.

Bis zu 4 Monate gratis surfen!
 Kein Aktivierungsentgelt⁰

HSDPA
 bis zu
7,2
 Mbit/Sek.



MORE THAN 400* HSPA DEVICES!

- › 203 HSPA phones, media players, camera (50%)
- › 161 PC with embedded HSPA, PC cards, USB modems (40%)
- › 39 wireless routers (10%)

2010 – 3G iPad!



COURTESY: APPLE INC. *launched as of August 2007*



OUTLINE

- › Introducing Ericsson Research Silicon Valley
- › Basic Principles
- › 3GPP Long Term Evolution (LTE)
- › LTE Advanced
- › Standardization
- › Summary

INTRODUCING ERICSSON RESEARCH SILICON VALLEY



ERICSSON RESEARCH SILICON VALLEY

PART OF OUR GLOBAL RESEARCH ORGANIZATION



Ericsson Research

- ~600 people
- GSM, 3G and LTE technologies were invented here
- Leading IP competence in IETF
- Delivers concepts and pre-commercial prototypes
- Files over 50 % of all Ericsson patents

ER Silicon Valley

- Packet Networking
- Open Application environment
- Radio Access Tech & Signal processing
- Led by Jan Söderström V.P. Research USA

RESEARCH FOCUS SILICON VALLEY

IP, Routers & Networks

Applications & Mobile Internet

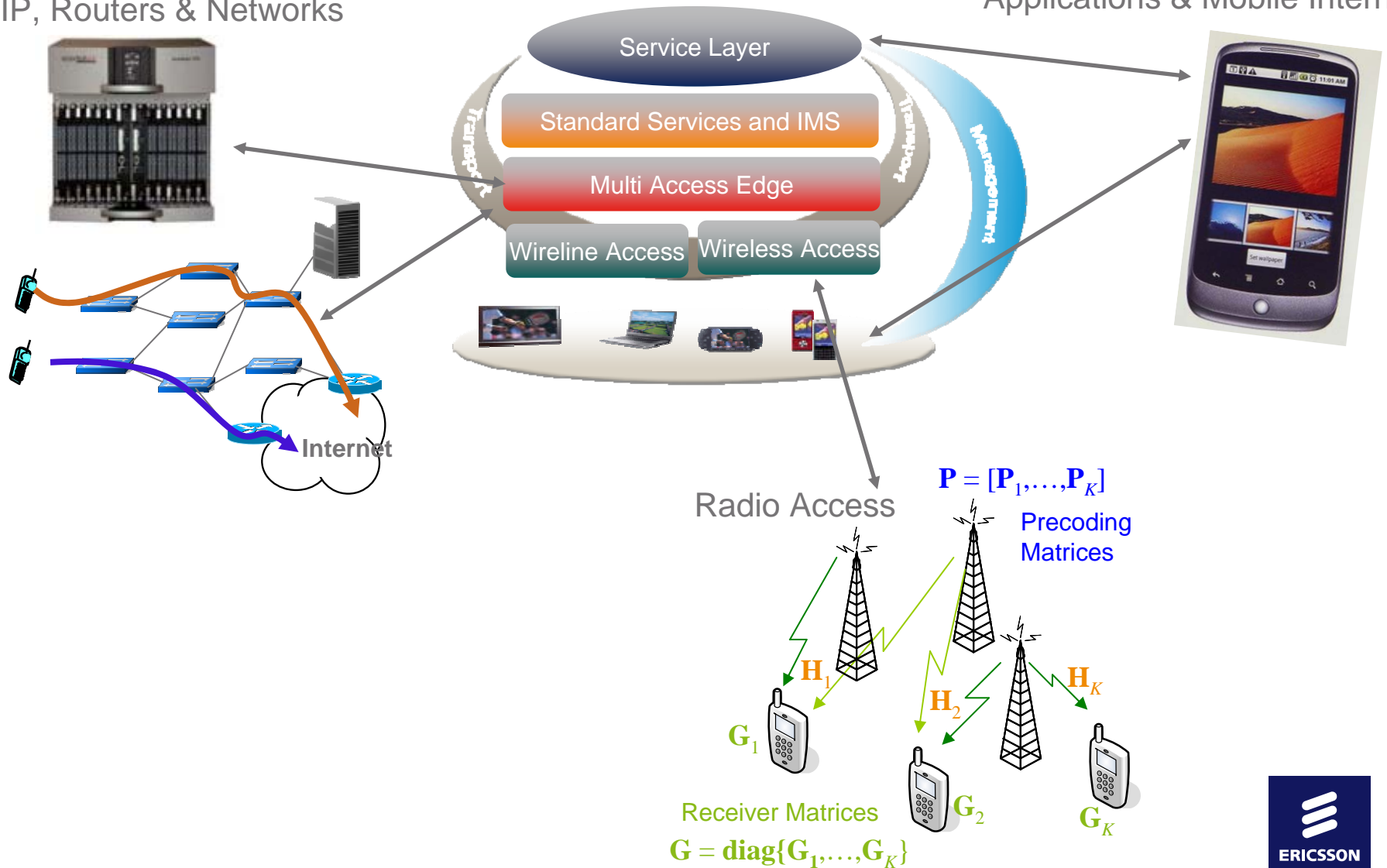

NEXT GENERATION INTERNET

Trends & Issues

Energy & heat



Security

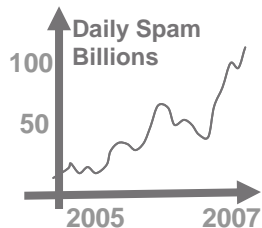

Botnets and Spoofing - Now an industry



Mobility

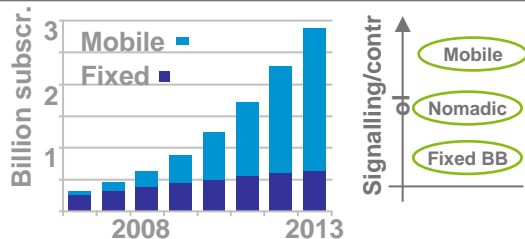

Lagging Deployment

Protocol X <--> Fully deployed
 >> 10 years
 Ex. IPv6, RSVP, HIP...

B-width & cost

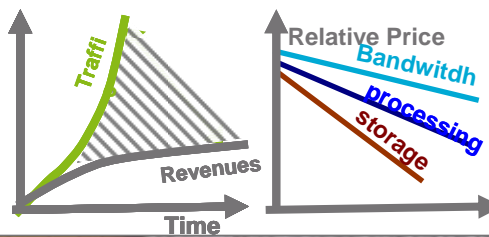

New Technologies

Cloud computing

SaaS

Google Apps (Gmail, MobileMe, Windows Live, SalesForce, Gliffy)

PaaS

Google AppEngine, Microsoft Azure, Sun Project Caroline, Force.com, Rollbase

IaaS

Amazon EC2, GoGrid, Joyent, Mosso, FlexiScale

NW Virtualization

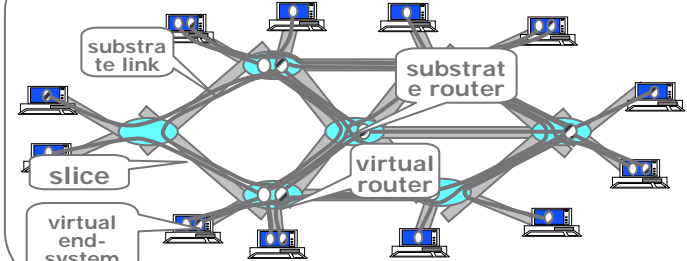

Mobile Broadband



A new network paradigm - without a clean slate deployment

BASIC PRINCIPLES



TREND – DATA IS OVERTAKING VOICE

- › Data is overtaking voice...
...but previous cellular systems designed primarily for voice

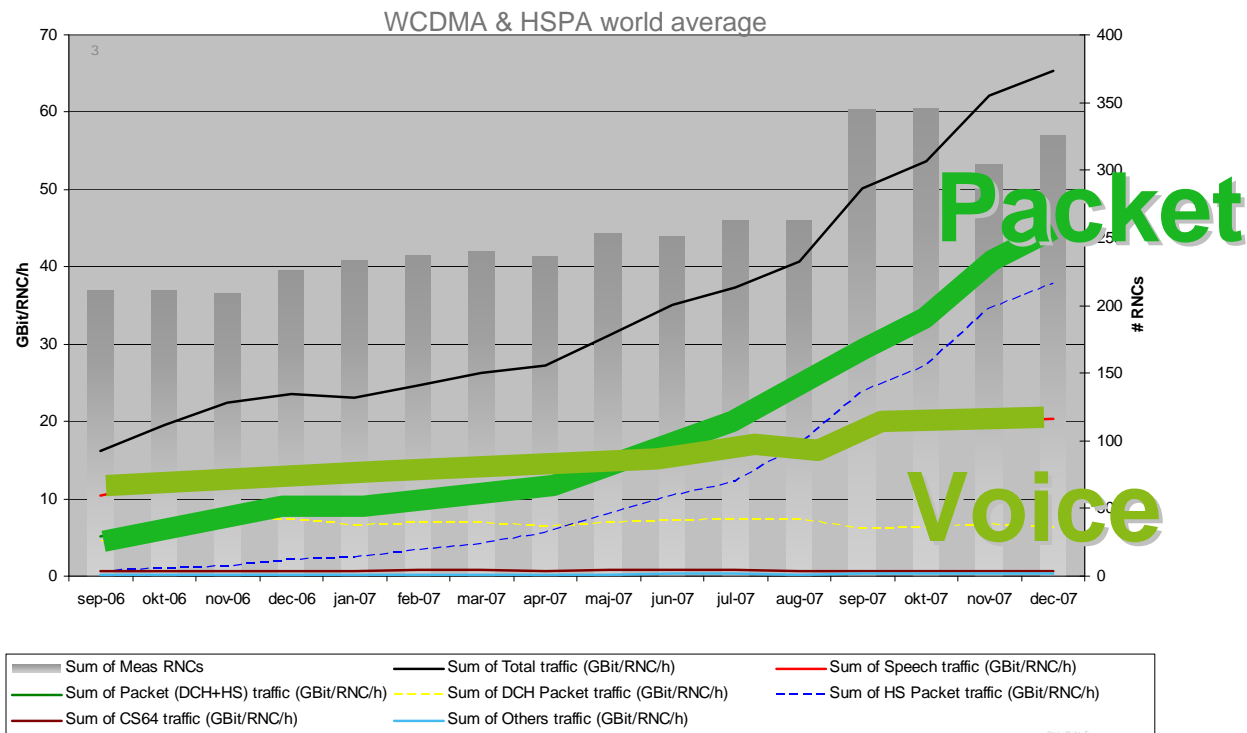

Source: NetQB



HISTORY

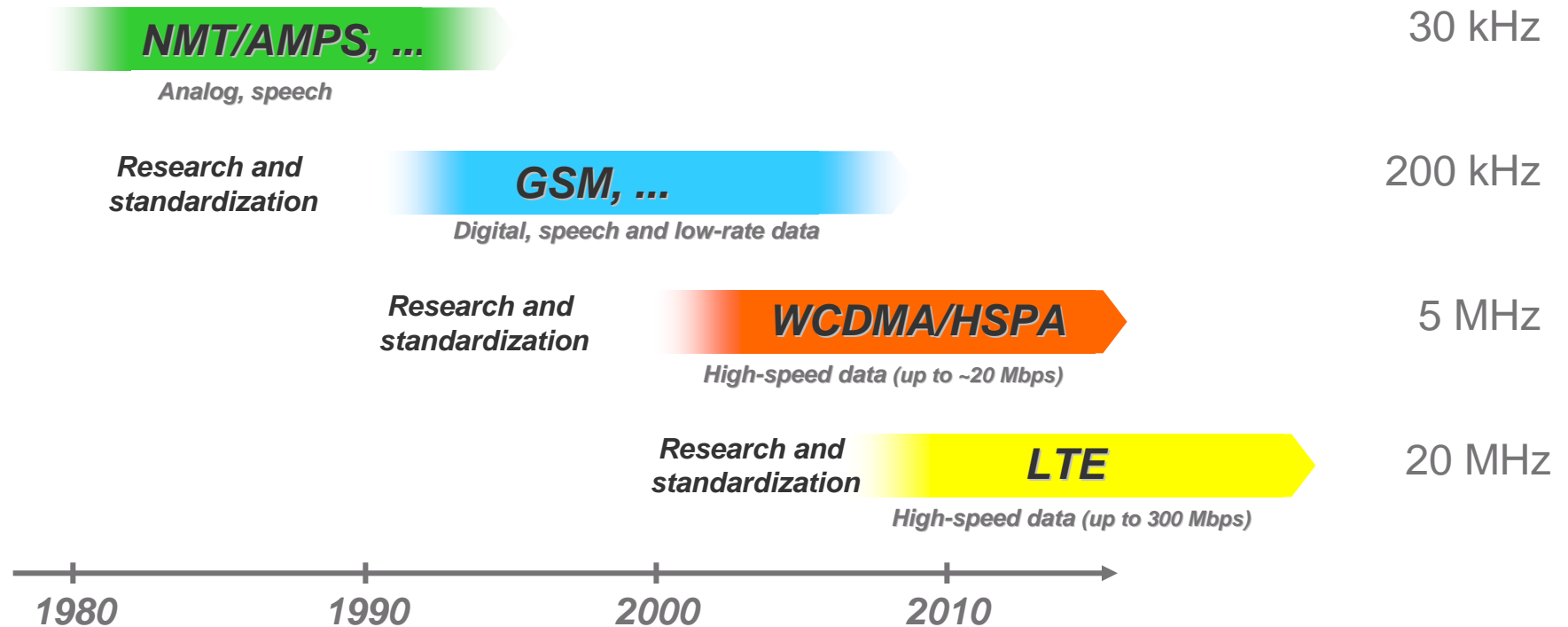

HSPA AND LTE = MOBILE BROADBAND

› HSPA – *High-Speed Packet Access*

- Evolution of 3G/WCDMA
- Gradually improved performance at a low additional cost
- Data rates up to ~40 Mbit/s in 5 MHz

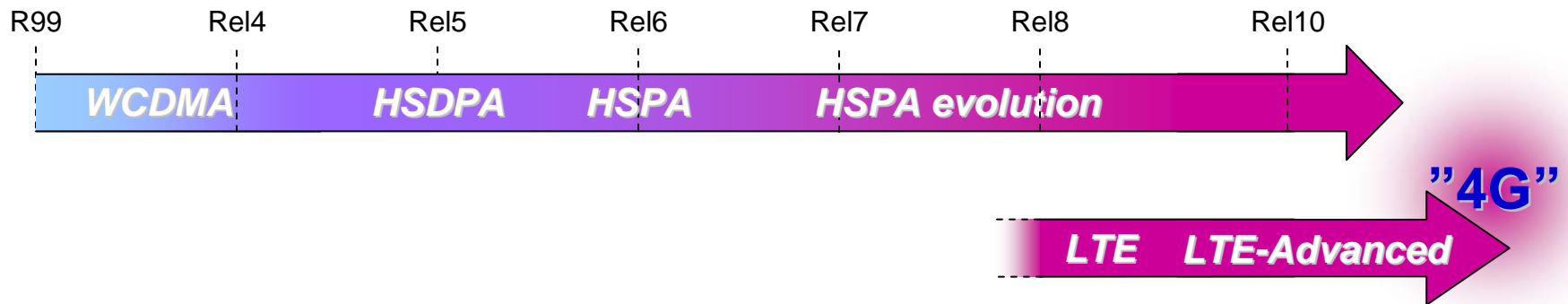

› LTE – *Long-Term Evolution*

- Significantly improved performance *in a wide range of spectrum allocations*
- Data rates up to ~300 Mbit/s in 20 MHz
- First step towards IMT-Advanced ("4G")

Extending broadband data networking from wired to wireless



WIRELESS VS WIRELINE

- › Many aspects are similar...
...but there are some fundamental differences!

Wireline

- › Cable
- › “No” spectrum limitation
 - over-provisioning
- › Relatively static channels
 - No fading
- › Congestion ⇒ lost packets
- › No mobility

Wireless

- › No cable 😊
- › Spectrum is scarce
 - Radio-resource management
- › Time-varying radio channel
 - Fast fading
- › Fading ⇒ lost packets
- › Mobility

RADIO-CHANNEL VARIATIONS

- › Transmitted power P_{Tx} ➔ received power $P_{Rx} < P_{Tx}$

- › Path loss
 - Given by Tx-to-Rx distance

- › Log-normal fading
 - Due to random variations in terrain (large scale)
 - Received signal strength in dB given by normal distribution

- › Fast fading
 - Random variations in environment
 - Often modeled by a Rayleigh distribution

Slow

Fast

RADIO-CHANNEL VARIATIONS

- › Transmitted signal reflected in numerous objects
 - multiple delayed signal copies received
- › 'Large' delay difference
 - components can be processed separately
- › 'Small' delay difference
 - components add constructively...
...or destructively
 - Large number of components
 - ➔ central-limit theorem
 - ➔ Gaussian-distributed amplitude
 - ➔ Rayleigh-distributed power (Rayleigh-fading, fast fading)

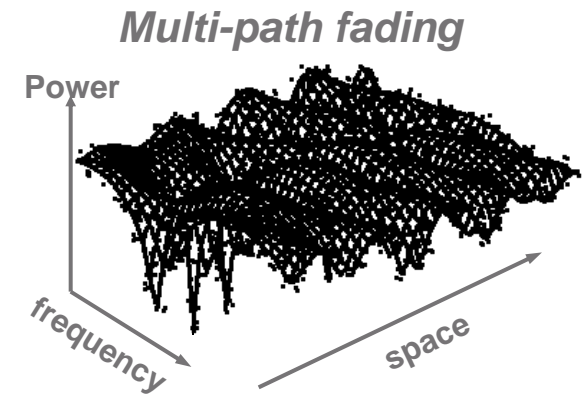
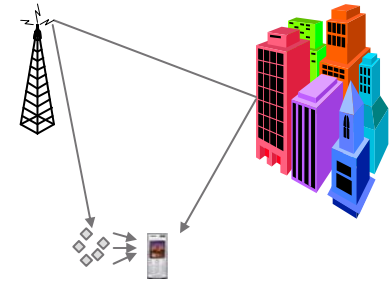

Radio-channels – rapidly varying signal quality

TRAFFIC VARIATIONS

- › Traditional voice services
 - Low, ~10 kbit/s, data rate
 - Fairly constant during the call
- › Packet-data services
 - Behavior depends on type of service
 - Typically rapidly and randomly varying rate requirements ('all-or-nothing' resource requirement)

} ➔ circuit-switched ok!

} ➔ packet-switched NW

Packet-data systems – rapidly varying data rates



TCP BASICS

- › TCP – Internet’s end-to-end transport layer protocol (non-real time)

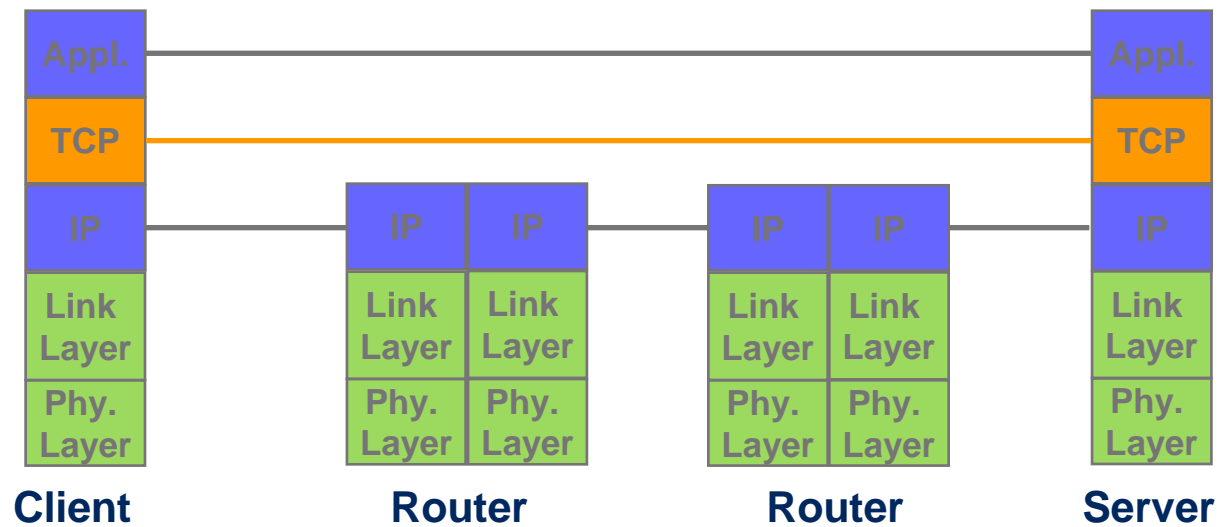

- › Main responsibilities of TCP:
 - provide reliable data transport
 - avoid congestion in the network

← Interaction with wireless links requires attention!

TCP BASICS

- › Error recovery and congestion control are intertwined
 - lost packets are used as congestion signal by TCP
 - ➔ radio-link errors should be 'hidden' from TCP
 - Lost packets ➔ timeout ➔ slow start

- › TCP congestion management

- Window = not-yet-ACKed packets in transmission
- Phase 1: Slow start
 - › Increase window by one on each received ACK
 - › window grows exponentially
- Phase 2: Congestion avoidance
 - › Increase window by $1/\text{window_size}$ on each ACK
 - › window grows linearly

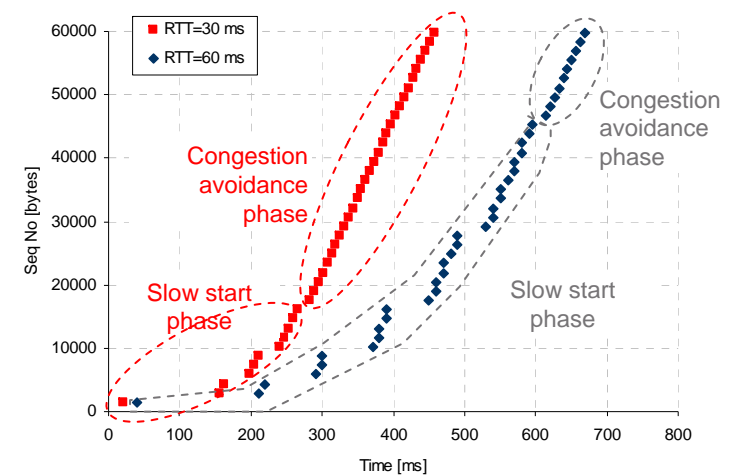

TCP BASICS

- › TCP performance determined by data rate *and* latency
 - High data rate alone not sufficient – need low latency as well
 - Delay-bandwidth product

Length of the pipe: Latency



Width of the pipe:
Data Rate

High data rate *and* low latency

RADIO CHANNELS AND PACKET DATA

- › Radio-channel quality varies...

- ...distance to base station
- ... random variations in the environment

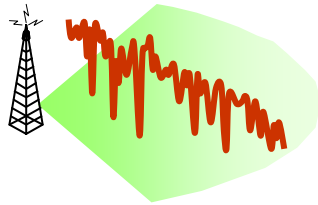

- › Traffic pattern varies...

- ...user behavior
- ...server load



Adapt to and ***exploit*** channel and traffic variations!

3GPP LONG TERM EVOLUTION (LTE)



LTE – BACKGROUND

› LTE – Long-Term Evolution

- Significantly improved performance [compared to HSPA]
in a wide range of spectrum allocations
- Data rates up to ~300 Mbit/s in 20 MHz
- First step towards IMT-Advanced ("4G")
- Packet-switched services only

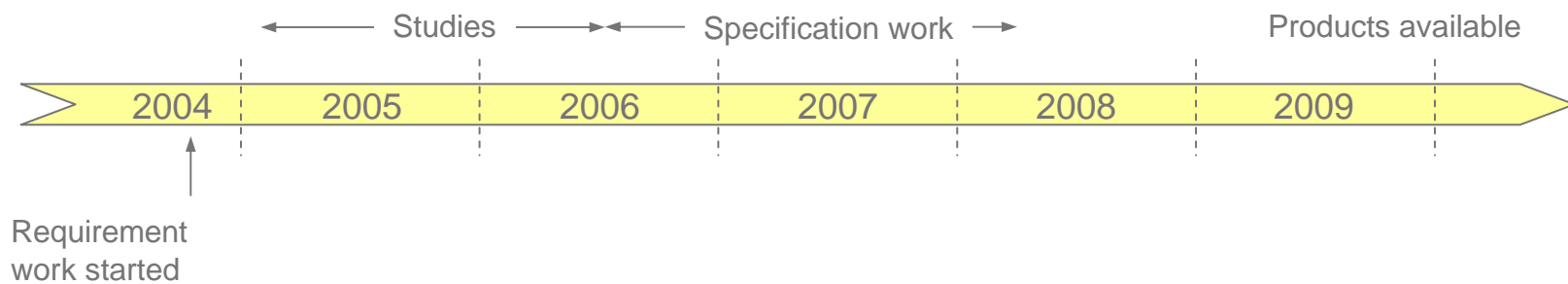

SPECTRUM FLEXIBILITY

- › Spectrum flexibility ➔ operation in differently-sized spectrum allocations

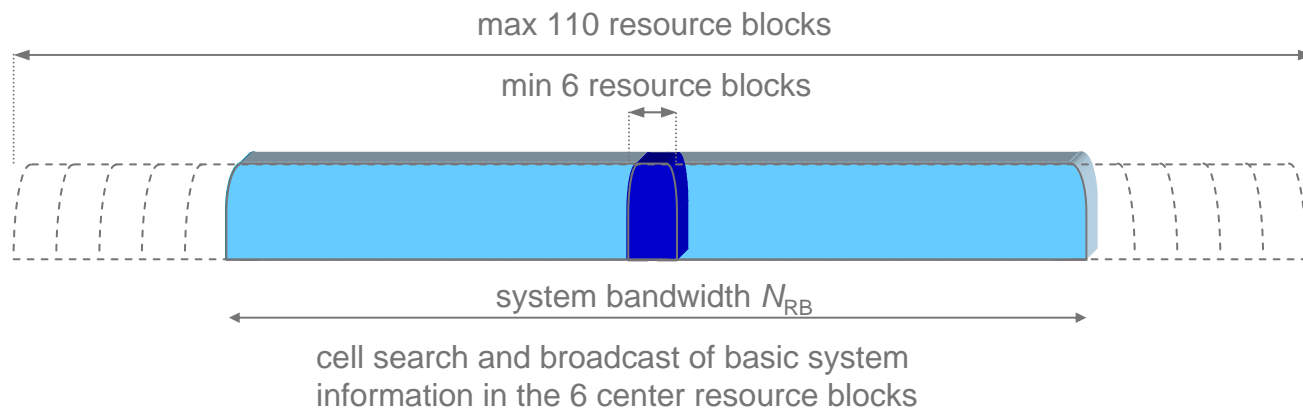

- › Support for paired *and* unpaired spectrum allocations

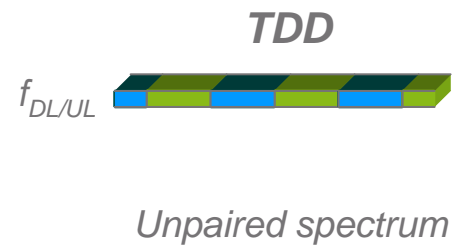
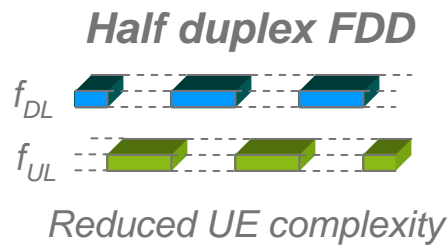
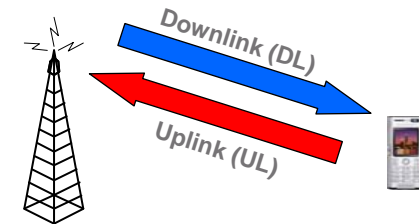

LTE RADIO ACCESS

Downlink: OFDM

- › Parallel transmission on large number of narrowband subcarriers

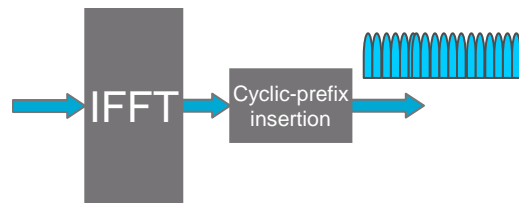

- › Benefits:
 - Avoid own-cell interference
 - Robust to time dispersion
- › Main drawback
 - Power-amplifier efficiency

Uplink: DFTS-OFDM

- › DFT-precoded OFDM

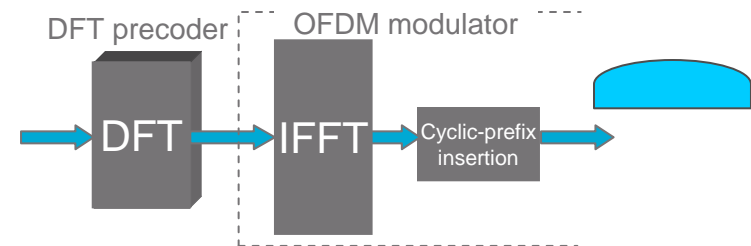

- › TX signal has single-carrier properties
⇒ *Improved power-amplifier efficiency*
 - Improved battery life
 - Reduced PA cost
 - **Critical for uplink**
- › Equalizer needed ⇒ *Rx Complexity*
 - **Not critical for uplink**

BASIC PRINCIPLES

› Shared-channel transmission

- Packet-data only
- No CS support

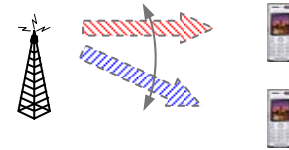

› Channel-dependent scheduling

- In time *and* frequency

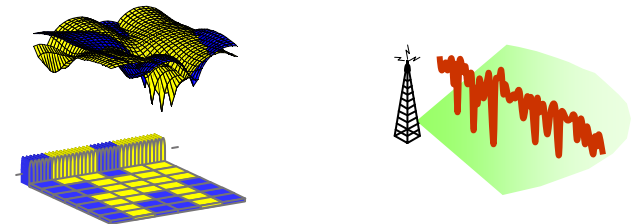

› Hybrid-ARQ with soft combining

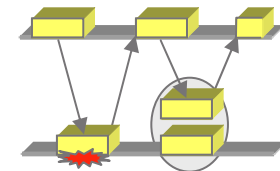

MIMO, ICIC, AND MBSFN

WHO SAID YOU WERE TIRED OF ABBREVIATIONS?

- › Multi-antenna support
 - Integral part of LTE
 - All terminals support at least 2 Rx antennas

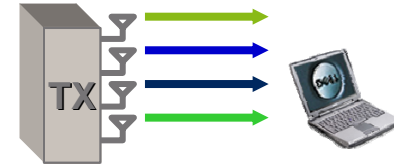

Multi-layer transmission
("MIMO")

- › ICIC
 - Inter-Cell Interference Coordination
 - To improve cell-edge performance

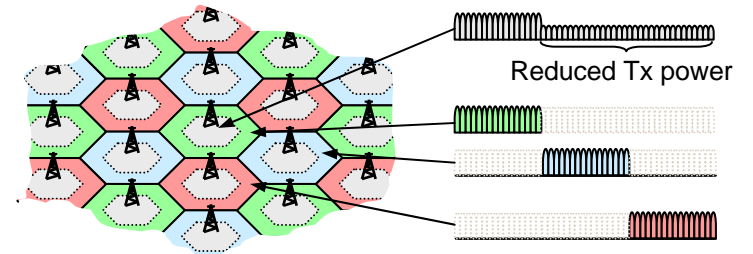

- › MBSFN
 - Multicast-Broadcast Single-Frequency Network

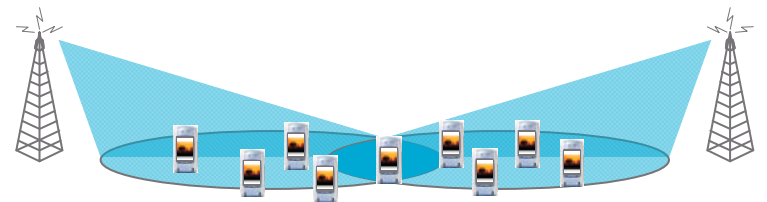

MULTI-ANTENNA TRANSMISSION TECHNIQUES

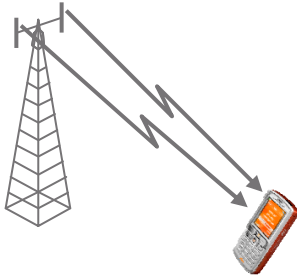

Diversity for improved system performance

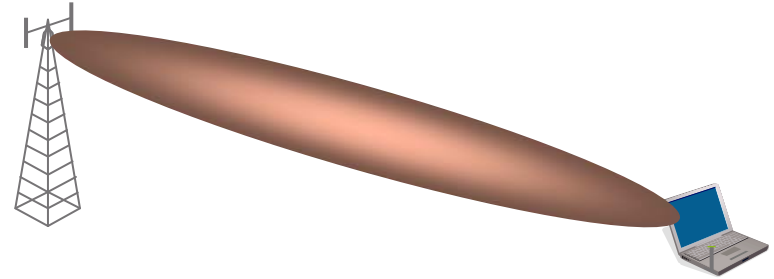

Beam-forming for improved coverage (less cells to cover a given area)

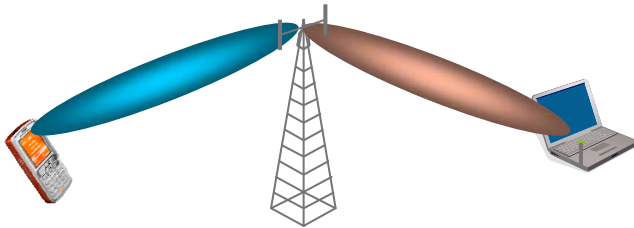

SDMA for improved capacity (more users per cell)

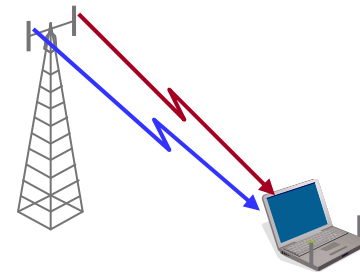

Multi-layer transmission ("MIMO") for higher data rates in a given bandwidth

The multi-antenna technique to use depends on what to achieve

HYBRID ARQ WITH SOFT COMBINING

- › Retransmission of erroneously received packets
 - Fast ➔ no disturbance of TCP behavior
- › Soft combining of multiple transmission attempts
 - Soft combining ➔ improved performance

- › Coding
 - add redundancy at transmitter
 - exploit redundancy at receiver to *correct* (most) transmission errors
 - code rate $R = k/n$, code rate fine tuned by puncturing
 - The lower the code rate, the lower the error rate but the higher the overhead

- › Hybrid-ARQ
 - *correct* most errors with coding
 - *detect* uncorrectable transmission errors, request retransmissions

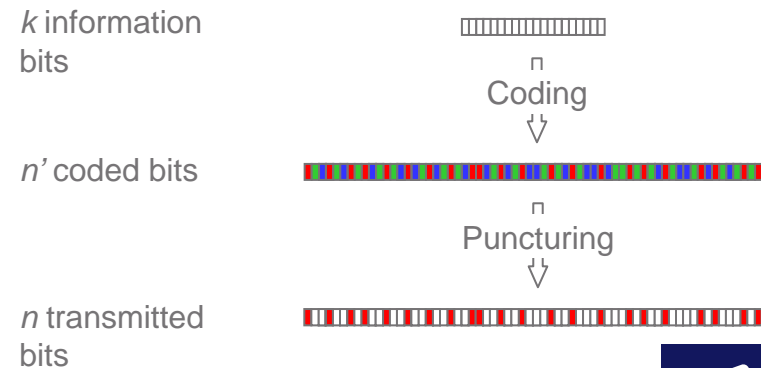
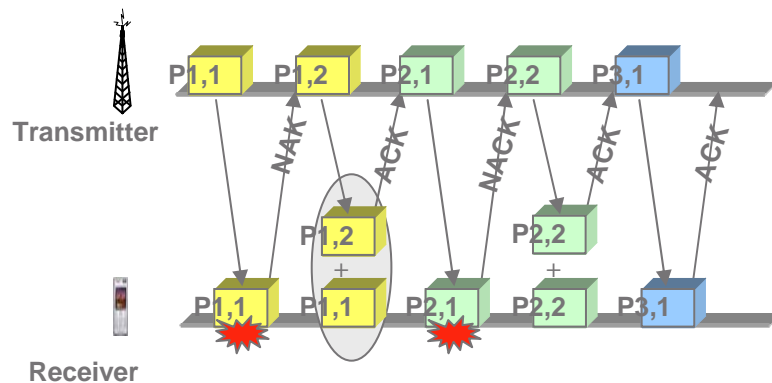

PROTOCOL ARCHITECTURE

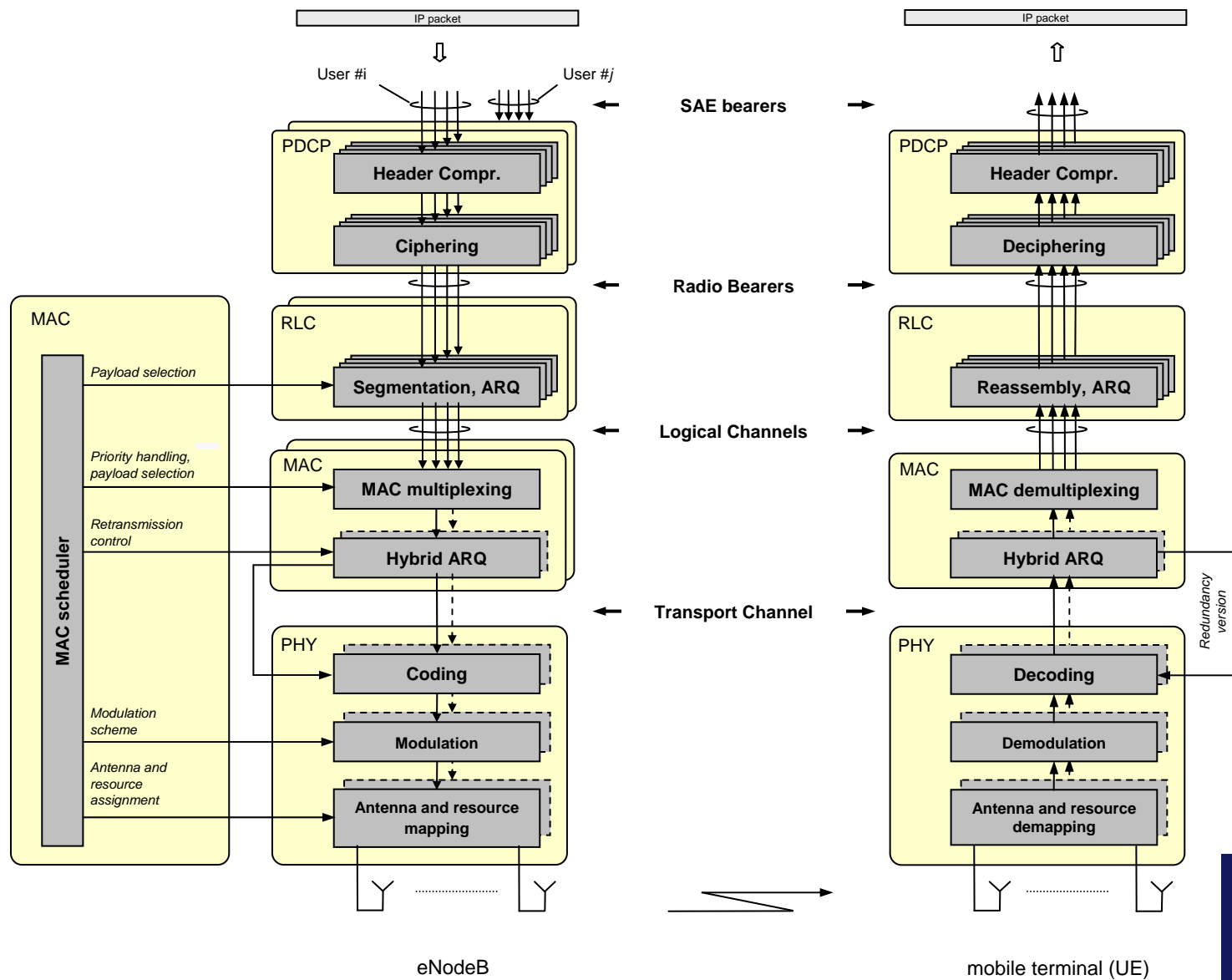

PROTOCOL ARCHITECTURE

- › PDCP – *Packet Data Convergence Protocol*
 - Header compression to reduce overhead
 - Ciphering for security
- › RLC – *Radio Link Control*
 - Segmentation/concatenation
 - RLC retransmissions
 - In-sequence delivery
- › MAC – *Medium Access Control*
 - Multiplexing of radio bearers
 - Hybrid-ARQ retransmissions
- › PHY – *Physical Layer*
 - Modulation, coding
 - Multi-antenna processing

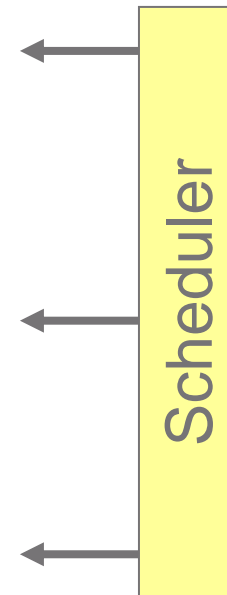

NETWORK ARCHITECTURE

- › Core network evolved in parallel to LTE
 - EPC – *Evolved Packet Core*
- › Flat architecture, single RAN node, the *eNodeB*
 - Compare HSPA, which has an RNC

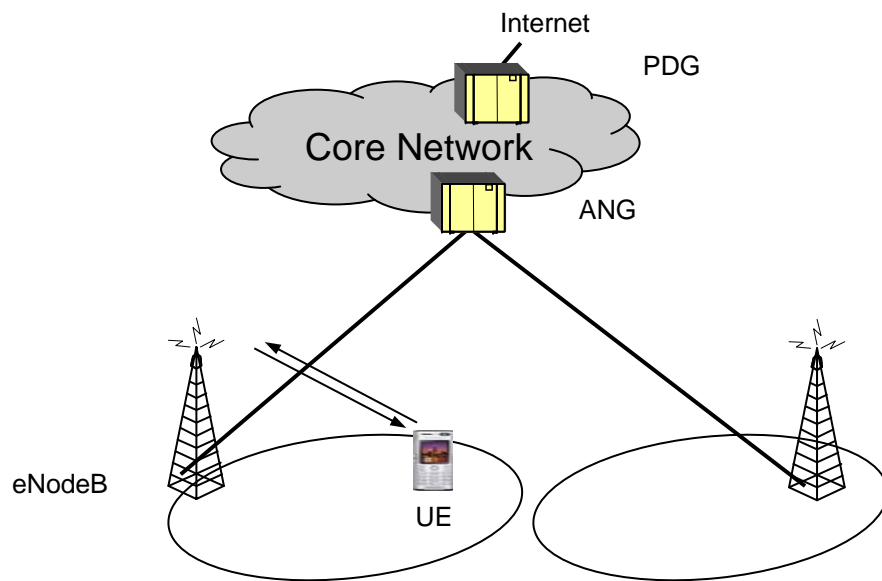

LTE

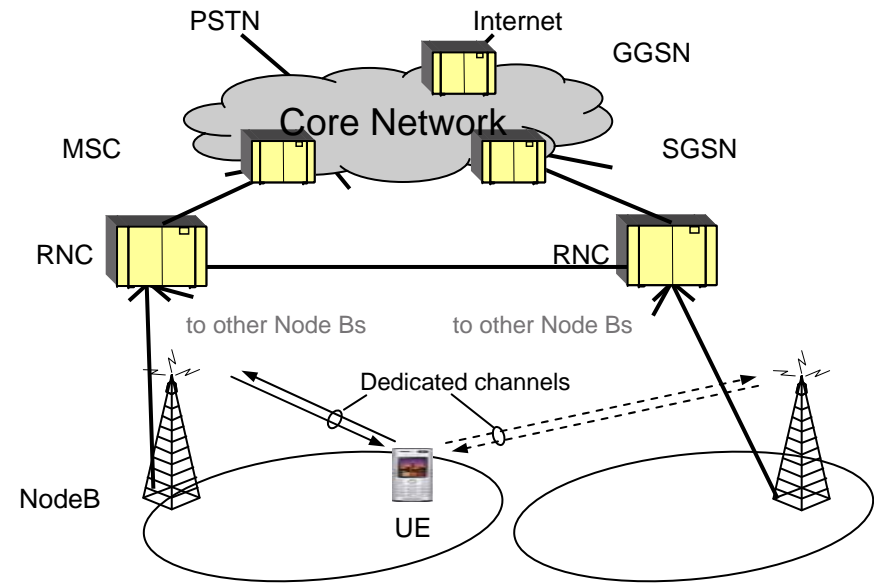

HSPA



LTE ADVANCED



LTE-ADVANCED

- › LTE-Advanced
 - the next major step of LTE evolution



- › LTE-Advanced should...
 - ...provide higher data rates
 - ...enable extended multi-antenna deployments and more dense infrastructure in a cost-efficient way
 - ...target low terminal *and network* power consumption
 - ...allow for smooth evolution from LTE

LTE-ADVANCED – TIME SCHEDULE

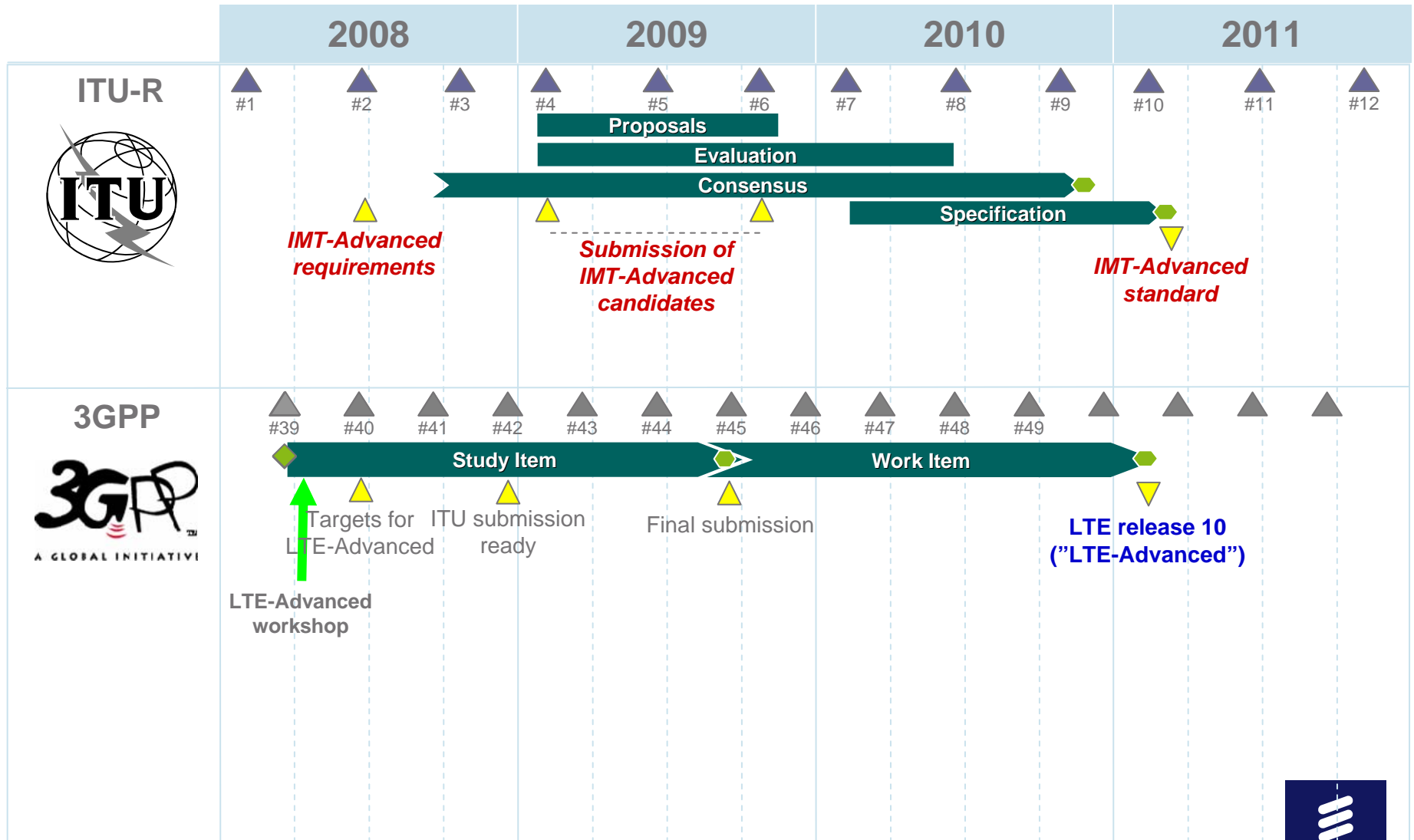

WIDER BANDWIDTH – CARRIER AGGREGATION

- › LTE-Advanced should support wider bandwidth
 - Needed for very high peak data rates
 - Needed for power-efficient support for high wide-area data rates
 - Specification should support up to at least 100 MHz
- › Spectrum compatibility \Rightarrow *Carrier aggregation preferred*
 - Aggregation of multiple component carriers into an overall wider bandwidth
 - Each component carrier appear as LTE R8 carrier to LTE R8 UE
 - LTE-Advanced UE can access and benefit from overall wider bandwidth

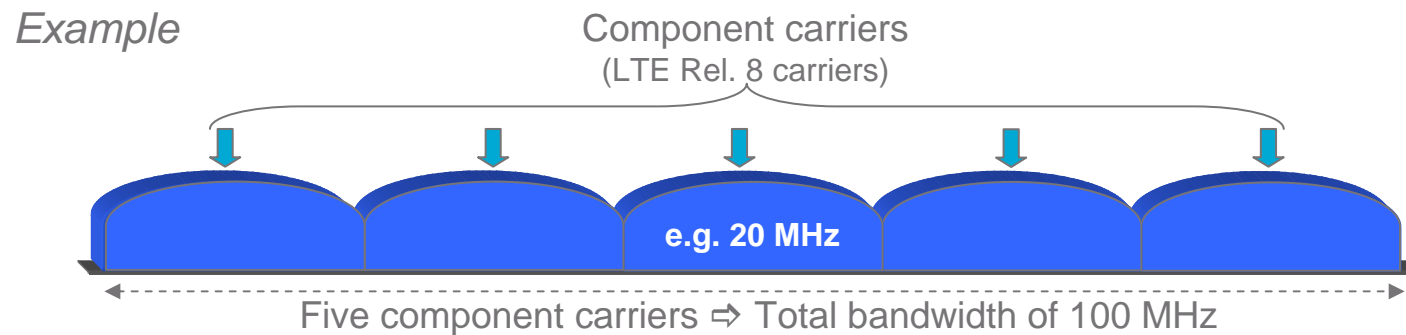

MULTI-ANTENNA SOLUTIONS

- › Further improved multi-antenna solutions
 - In addition to the ones already in LTE

*Higher data rates,
improved cell edge performance*

} → *High SNR
required*

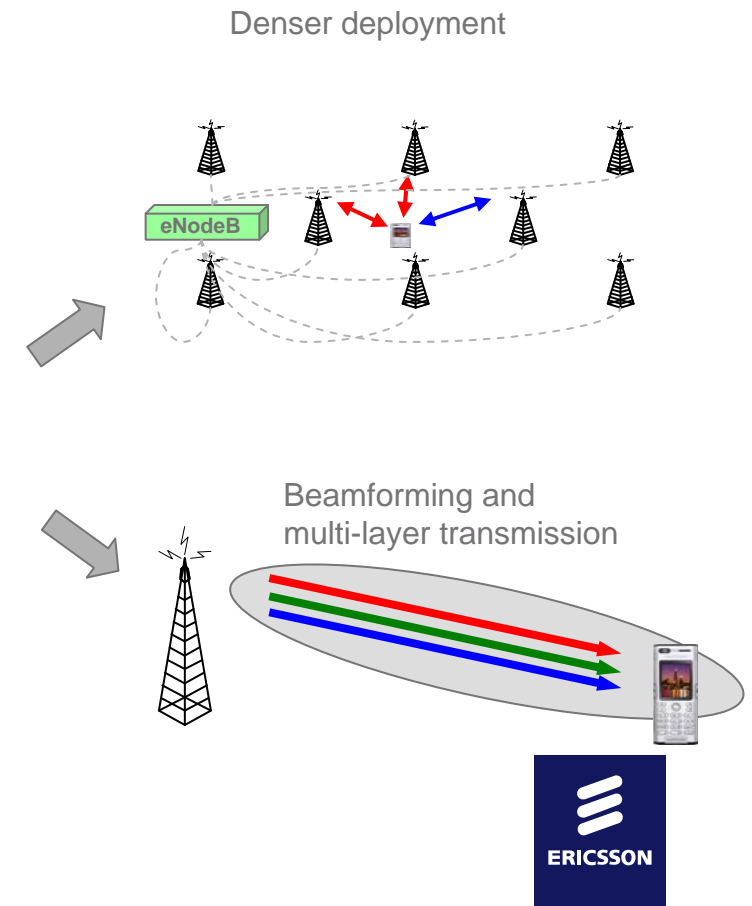

COST-EFFICIENT DENSE INFRASTRUCTURE

SELF-BACKHAULING AND RELAYING

- › LTE radio access in the back-haul
- › Wireless connection of eNodeB to central hub
- › Shared or separate spectrum

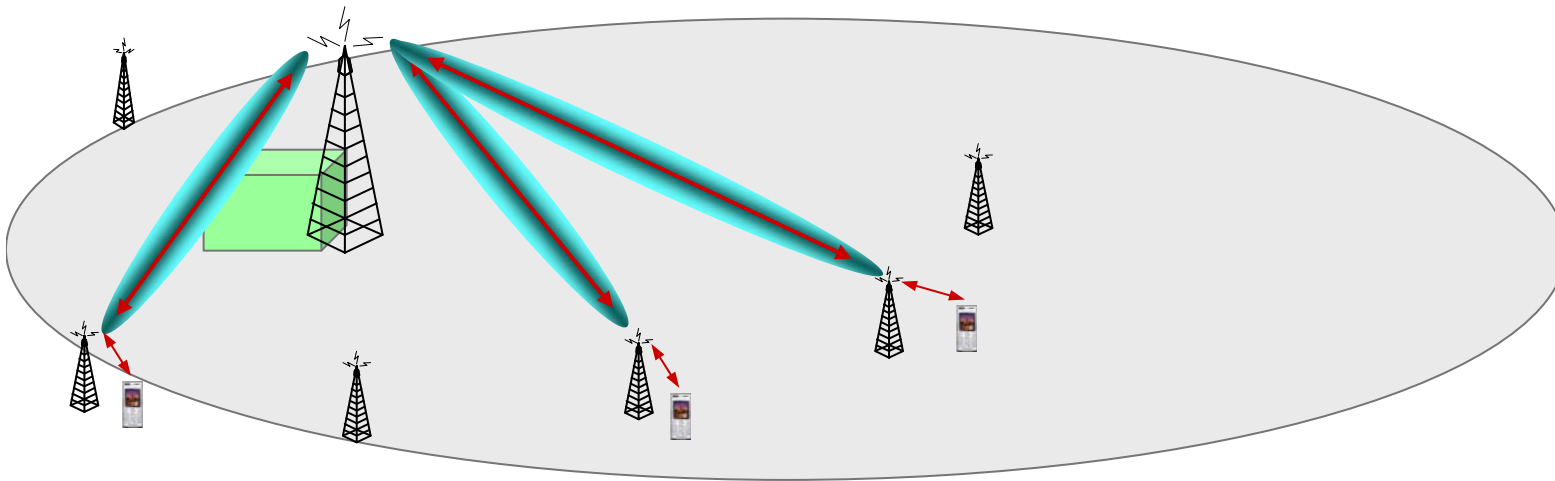

STANDARDIZATION



WHY STANDARDIZATION?



- › From Wikipedia
 - Standardization is the process of agreeing on technical standards
 - A standard is a document that establishes uniform engineering or technical specifications, criteria, methods, processes, or practices.
 - Some standards are mandatory while others are voluntary. Some standards are de facto, meaning informal practices followed out of convenience, meaning formal requirements...
 - The goals of standardization can be to help with independence of single suppliers (commodification), compatibility, interoperability, safety, repeatability, or quality.
- › Interoperability – e.g. Nokia phone in Ericsson network
- › Creates mass market! Economy-of-scale!

WHAT IS STANDARDIZED?

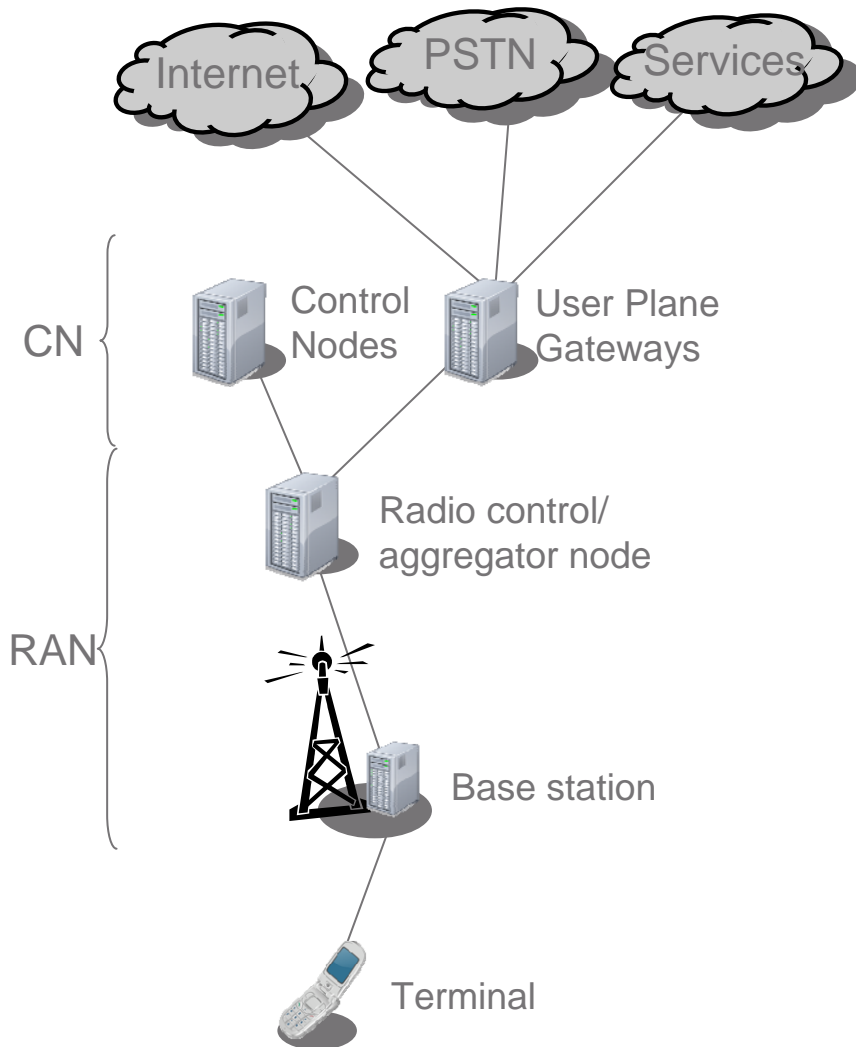

Standardized – ensures interoperability

- › Logical architecture
- › Protocol on interfaces
- › Radio transmitters (RF aspects)
 - required by regulations/law
- › Behavior required to fulfill functionality
 - Terminals standardized according to "master-slave principle"

Not standardized – vendor differentiation

- › Physical implementation
- › Algorithms
 - Scheduler, handover, admission, ...
 - Receiver algorithms – sufficient to fulfill requirements

WHERE – SOME STANDARDIZATION FORA



- › 3GPP
 - Core Network and Radio Access Network for WCDMA/HSPA, LTE, GSM/GPRS/EDGE



- › 3GPP2
 - Standardization of IS-95, cdma2000/HRPD, UMB



- › IEEE
 - Large variety of stds, e.g. 802.11 (WiFi) and 802.16 (WiMAX)



- › WiMAX Forum
 - Promote conformance and interoperability of 802.16 standards



- › IETF
 - Develops/promotes internet standards (IP, TCP, FTP, ROHC, ...)



- › ITU
 - International radio and telecommunications standards, allocation of spectrum. Part of UN.



WHERE IN THE NETWORK?

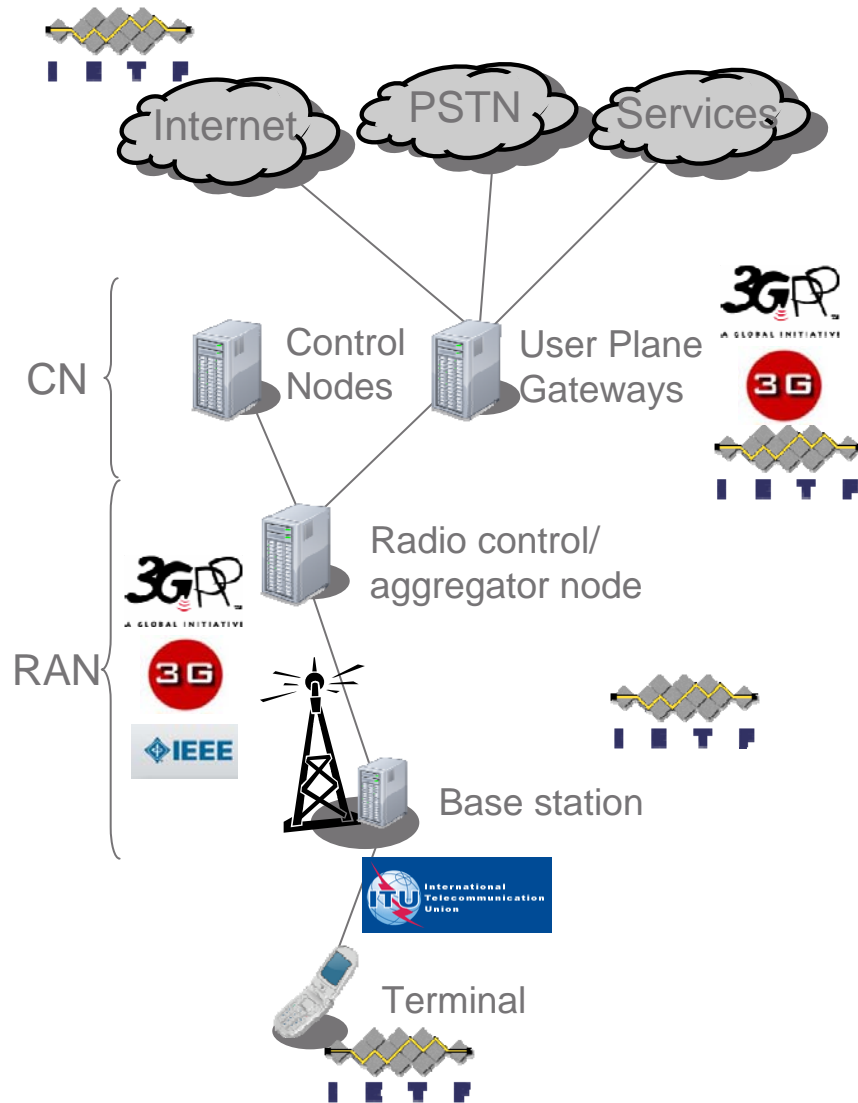

- › IETF
 - Internet services/protocols end-to-end with the terminal (e.g. IP, TCP, ROHC)
 - Transport protocols/functions in the CN (IP, MIP)
- › 3GPP, 3GPP2
 - Architecture, functions, protocols for the complete Radio Access and Core Network
- › IEEE
 - Architecture, functions, protocols for Radio Access Network
- › ITU
 - Spectrum, radio regulations

STANDARDIZATION PROCESS

Requirements



Architecture



Detailed specifications



Testing and verification



Certification

- › Stage 1
 - Requirements, no detailed solutions

- › Stage 2
 - Logical architecture, functional split, interfaces, protocol architecture, overall solutions

- › Stage 3
 - All details, e.g., header formats, exact coding scheme, values in requirements, ...

- › Test
 - Snapshots with test cases from standard to ensure proper operation

STANDARDIZATION IN PRACTICE

- › Contribution driven
- › Decision by consensus
 - Coffee-breaks important part of meetings (off-line)
- › Good relations important
 - Social relations across cultural borders
 - Mutual respect and co-operation
- › One week meetings ➔ Long meeting days

SUMMARY

SUMMARY – BASIC PRINCIPLES

› Radio-channel quality is time varying

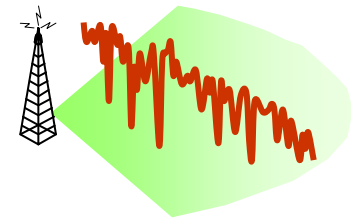

› Traffic pattern is time varying



› **Adapt to** and **exploit**...

- variations in radio channel quality
- variations in the traffic pattern

...instead of combating them!

SUMMARY – BASIC PRINCIPLES

- › Shared channel transmission

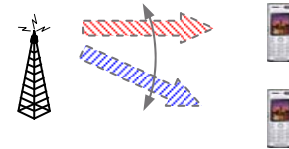

- › Channel-dependent scheduling

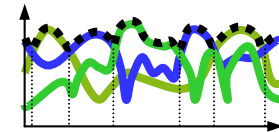

- › Rate control

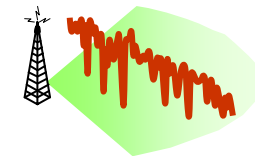

- › Hybrid-ARQ with soft combining

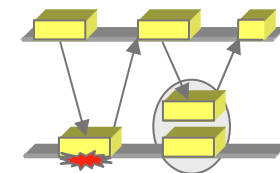

SUMMARY – HSPA AND LTE

› HSPA – *High-Speed Packet Access*

- Evolution of 3G/WCDMA
- Gradually improved performance at a low additional cost
- Data rates up to 42 Mbit/s in 5 MHz

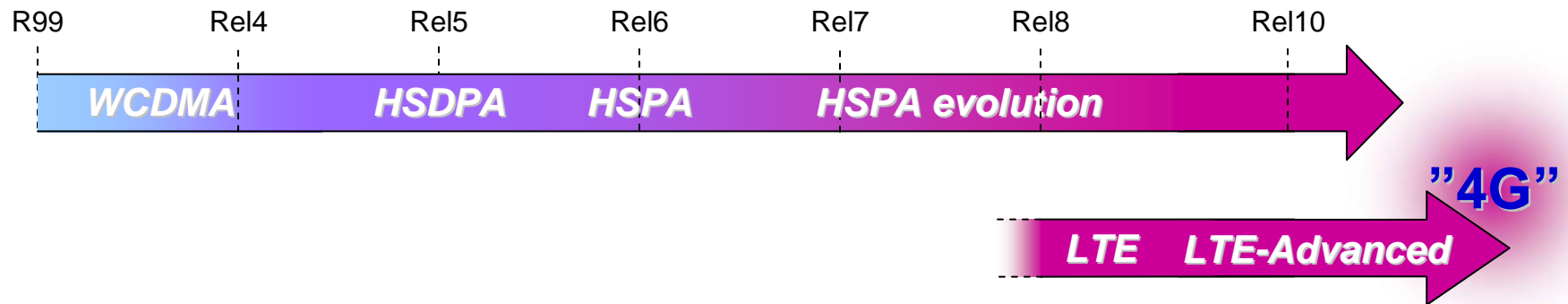

› LTE – *Long-Term Evolution*

- Significantly improved performance *in a wide range of spectrum allocations*
- Data rates up to 300 Mbit/s in 20 MHz
- First step towards IMT-Advanced ("4G")

SUMMARY – STANDARDIZATION

- › Interfaces and protocols standardized
 - Implementation is not
- › 3GPP
 - Standardization of radio-access and core network for the major mobile technologies
- › ITU
 - Radio regulations, spectrum allocations



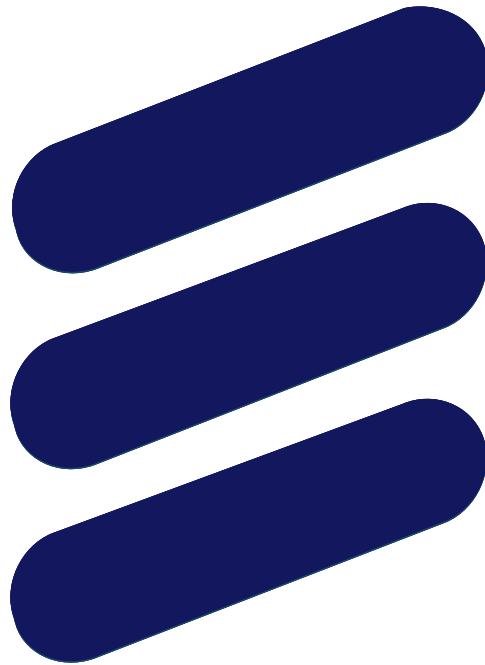

ERICSSON