

# Linearization and its discontents

Robert Levine

Ohio State University

Proceedings of the 18th International Conference on  
Head-Driven Phrase Structure Grammar

University of Washington

Stefan Müller (Editor)

2011

CSLI Publications

pages 126–146

<http://csli-publications.stanford.edu/HPSG/2011>

Levine, Robert. 2011. Linearization and its discontents. In Müller, Stefan (Ed.), *Proceedings of the 18th International Conference on Head-Driven Phrase Structure Grammar, University of Washington*, 126–146. Stanford, CA: CSLI Publications.



## Abstract

Much recent work on coordination in the HPSG framework seeks to deal with some of the most intractable issues this phenomenon poses for a constraint-based phrase structure architecture by appealing to the linearization mechanism introduced in Reape 1993. The research in question utilizes the mismatch between linear phonological sequences on the one hand and phrasal configuration on the other to underwrite a particular interpretation of ellipsis in which multiple structural objects with identical or near-identical descriptions are mapped to a single *dom-object* token. This mapping apparently allows a variety of problematic cases, such as right node raising, dependent cluster coordination, and unlike category coordination to be reinterpreted as instances of ordinary coordination in which structurally present elements receive no prosodic expression, creating the impression that strings which do not correspond to constituents of the same category have nonetheless been conjoined or disjoined. I argue in this paper that such linearization-based ellipsis (LBE) analyses, though plausible when confined to a narrow class of simplest-case data, prove untenable in the face of data sets in which the LBE approach must account for the interaction of nonconstituent coordination and quantification or symmetric predication, symmetrical modification of nominal heads, and a large and varied class of unlike category coordinations that do not admit of any ellipsis-based solutions. I show in addition that various objections offered in the LBE literature to categorial grammar treatments of the problems posed by noncanonical coordinations do not take into account technical resources available to CG which permit straightforward and unproblematic solutions to these problems. One must conclude that despite the general popularity of LBE accounts of conjunction, there is at the moment no satisfactory HPSG treatment of noncanonical coordinations.

## 1 Coordination via Linearization-Based Ellipsis

The simplest story about coordination is very simple indeed: only constituents belonging to the same category can coordinate. Unfortunately, this characterization of the possibilities cannot be maintained, in the face of examples such as (1):

- (1) a. I gave Robin a book and Terry a pair of pliers.
- b. I gave Robin, and Leslie offered Terry, a pair of pliers.
- c. That man and woman are arguing again.
- d. Robin is a Republican and proud of it.

In (1)a-b, non-constituents are conjoined. In (1)c, the problem is not that there is any evident conjunction of nonconstituents, but rather that the coordination seems to have mutually incompatible specifications for number: singular so far as agreement with the specifier *that* is concerned, but plural for purposes subject/verb agreement. In (1)d, the conjuncts are of different categories.

The HPSG literature on difficult coordination phenomena over the past decade contains a particular strand of analysis based on a kind of data structure first introduced in

---

<sup>†</sup>The work reported below has been incorporated into a large-scale joint research project with Yusuke Kubota, to whom I am greatly indebted for extremely perceptive comments on earlier drafts of this paper and closely related manuscripts. I wish to thank in addition Bob Borsley, Carl Pollard and Mike Reape for very useful feedback on many of the analyses, arguments and examples offered below. None of them bear any responsibility for errors or shortcomings in the following discussion.

Reape 1993, Reape 1996, and later widely adopted in studies of conjunction, based on the DOM attribute as per the feature architecture in (2):

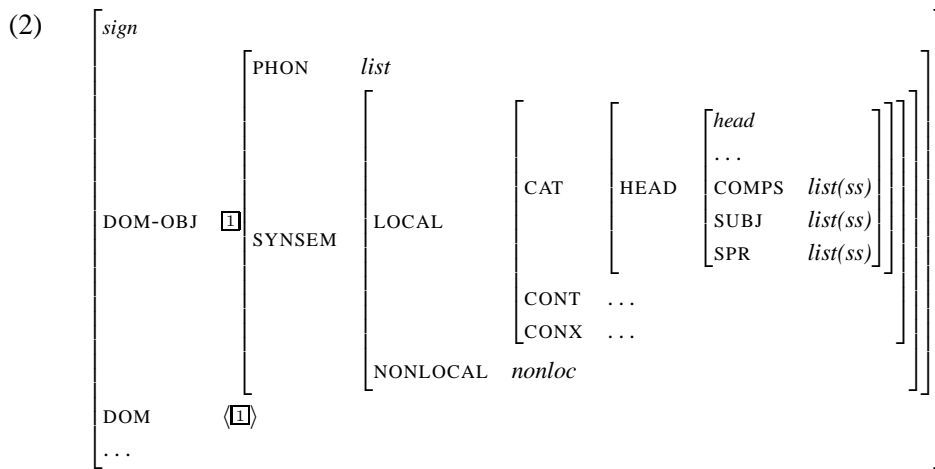

Lexical items contribute their phonology and synsem properties to a dedicated list, the DOM specification. Crucially, the DOM specification of a sentence, and of phrases in general, need not represent a simple concatenation of the DOM values of its parts, but rather may represent the shuffling-together of its daughters' own DOM values. Thus, elements belonging to different constituents may correspond to pronunciations in which prosodic expression of those elements are intermixed. Thus, while constituency itself is never discontinuous, the phonological instantiation of constituents may well be. As a consequence of the rules determining under what conditions DOM lists may be shuffled together, and the principles regulating what ordering relations hold amongst different phrasal types, the following kind of representation receives a legal description in an HPSG grammar of English, where  $\oplus$  denotes the **append** operator:

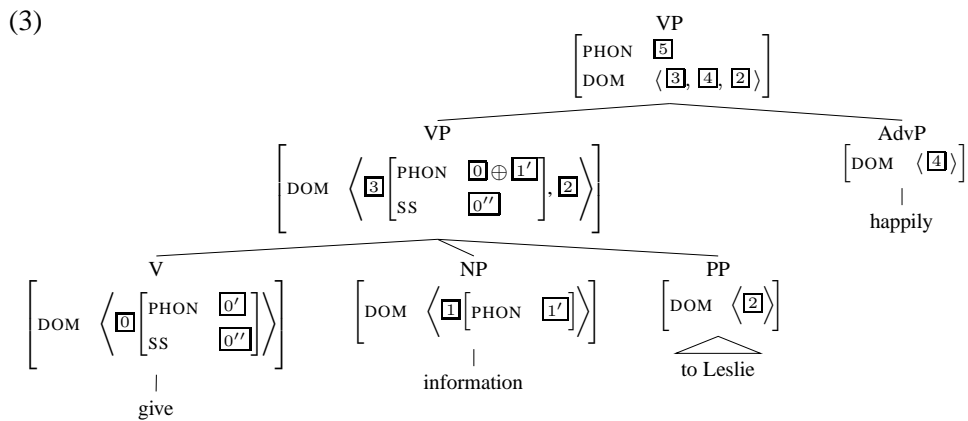

By separating out constituency on the one hand from the formation of domains in which word order is defined on the other, we can reconcile the hierarchical representation in 3) with the pronunciation *I gave information happily to Leslie*. This crucial decoupling of prosody and constituency which raises the possibility of a more general approach to form/meaning mismatches: components of an interpretation which are unpronounced now have a place in the architecture of syntactic representation. The

approach alluded to above, which offers a unitary treatment of the phenomena in (1), rests on an extension of the linearization framework playing heavily on this treatment of misalignments between the apparent structure and the manifest interpretation of coordinations such as those in (1).

One influential proposal implementing the linearization approach to such data takes the form of a condition on coordination given in (4).

$$(4) \quad \left[ \begin{array}{c} \text{DOM} \quad \boxed{X} \oplus \boxed{A}_{\text{nelist}} \oplus \boxed{Y} [\text{CAT} \textit{conj}] \oplus \boxed{B}_{\text{nelist}} \\ \text{CAT} \quad \boxed{0} \end{array} \right] \\ \left[ \begin{array}{c} \text{DOM} \quad \boxed{X} \langle [\text{RELS } R_1] \dots [\text{RELS } R_n] \rangle \oplus \boxed{A} \\ \text{CAT} \quad \boxed{0} \end{array} \right] \quad \left[ \begin{array}{c} \text{DOM} \quad Y \oplus \langle [\text{RELS } R_1] \dots [\text{RELS } R_n] \rangle \oplus \boxed{B} \\ \text{CAT} \quad \boxed{0} \end{array} \right]$$

This principle—which in essence tells you that for a given input, different parses of the domain in the two conjuncts permit the ellipsis of different substrings—is subject to the condition in (5), dictating that when coordination syntactically links two or more clauses, the meaning of the coordination must be the yield of the logical operation corresponding to coordination taking as its arguments the semantics specifications of each daughter:

(5) **Principle of Semantic Compositionality:** for all structures,

$$\left[ \begin{array}{c} \text{CONT|RELS} \quad \bigoplus_{j=1}^n \boxed{R_j} \end{array} \right] \\ \left[ \begin{array}{c} \text{CONT|RELS} \quad \boxed{R_1} \end{array} \right] \quad \dots \quad \left[ \begin{array}{c} \text{CONT|RELS} \quad \boxed{R_n} \end{array} \right]$$

Thus we can get, from two sentences whose *tectogrammatical* form (following the terminology in Curry 1963) would be realized as *Robin gave a book to Terry* and *Robin gave some flowers to Pat*, a domain object on the mother of the conjunction of these two sentences which corresponded to *Robin gave a book to Terry and Robin gave some flowers to Pat*. But we could equally well assign  $\boxed{X}$  as in (6)a. In that case, the coordination rule schematically stated in (4) will yield the structure in (6)b:

(6) a.  $\boxed{X} = \langle I, \textit{gave} \rangle$

$$\text{b.} \quad \left[ \begin{array}{c} \text{S} \\ \text{DOM} \quad \langle I, \textit{gave}, \textit{Robin}, a, \textit{book}, \textit{on Thursday}, \textit{and}, \textit{Leslie}, a, \textit{book}, \textit{on Friday} \rangle \end{array} \right] \\ \left[ \begin{array}{c} \text{S} \\ \text{DOM} \quad \langle I, \textit{gave} \rangle \oplus \langle \textit{Robin}, a, \textit{book}, \textit{on Thursday} \rangle \end{array} \right] \left[ \begin{array}{c} \text{S} \\ \text{DOM} \quad \langle \textit{and} \rangle \oplus \langle I, \textit{gave} \rangle \oplus \langle \textit{Leslie}, a, \textit{book}, \textit{on Friday} \rangle \end{array} \right]$$

c. I gave Robin a book on Thursday and ~~I gave~~ Leslie a book on Friday.

In short, it turns out that we do not have non-constituent coordination, but rather coordination of ordinary, structurally canonical constituents, where part of the second syntactically coordinated constituent is concealed in the form of prosodic silence—thereby giving the impression of not actually being there. We henceforth adopt a

convention on the notation of ellipsis whereby the analysis in (6)b is abbreviated as (6)c. Similarly, the other cases exemplified in (1)b–d can be treated as ellipses along the lines in (7):

- (7) a. [<sub>S</sub> I gave Robin ~~a pair of pliers~~] [<sub>S</sub> and [<sub>S</sub> Leslie offered Terry, a pair of pliers]].  
 b. [<sub>NP</sub> That man] and [<sub>NP</sub> ~~that~~] woman are arguing again.  
 c. [<sub>S</sub> Robin is a Republican] and [<sub>S</sub> ~~Robin is~~ proud of it.]/Robin [<sub>VP</sub> [<sub>VP</sub> is a Republican] and [<sub>S</sub> is proud of it.]]

In all these cases, the linearization-based solution uses the same fundamental technique: ellipsis is made responsible for concealment of material which is structurally present and which combines with the audible elements to yield a canonical constituent of the same type as the other conjunct.

Unsurprisingly, the linearization-based ellipsis (LBE) approach's apparent reduction of a diverse range of problem coordinations to a single factor, and its ability to motivate that factor, has earned it something close to default status in certain parts of the HPSG research community—but, as I argue directly, quite prematurely. The examples in (1) prove to be strikingly unrepresentative of the full range of data in this empirical domain, and the LBE account has only highly stipulative technology at its disposal to handle any but the simplest-case difficulties exhibited above. When elements corresponding to negations appear in the ellipsis environments illustrated in (6)–(7), LBE analyses entail nontrivial mispredictions unless strikingly unprincipled escape hatches are adopted—and even more so in the case of symmetrical predicates in such environments, e.g. *same/equal/different/ill-suited/mutually hostile*. It turns out that it is precisely the assumption that structural real but inaudible material exists in these syntactic contexts which leads to the difficulties alluded to—difficulties which the LBE analysis can only overcome by in effect stipulating operations which undo the effect of assuming such material.

## 2 LBE: major contraindications

### 2.1 Nominal head coordination under a singular determiner

Consider first examples such as (8)–(13), based in part on data in Heycock & Zamparelli 2005, §6.3:

- (8) a. That ill-matched man and woman are fighting again.  
 b. \*That ill matched man and that ill-matched woman are fighting again.
- (9) a. That mutually hostile judge and defense attorney were constantly sniping at each other during the trial.  
 b. \*That mutually hostile judge and that mutually hostile defense attorney were constantly sniping at each other during the trial.
- (10) a. Suppose an entangled particle and antiparticle are created in the vicinity of a mass singularity as a vacuum fluctuation in a region subject to an extreme gravitational potential.  
 b. #Suppose an entangled particle and an entangled antiparticle are created in the vicinity of a mass singularity.

- (11) a. In unusual cases, a reciprocally antagonistic primary and secondary infection give rise to a completely asymptomatic presentation.  
 b. \*In unusual cases, a reciprocally antagonistic primary and a reciprocally antagonistic secondary infection give rise to a completely asymptomatic presentation.
- (12) a. \*That creep<sub>i</sub> and friend of his<sub>i</sub> are not welcome in this house.  
 b. That creep<sub>i</sub> and that friend of his<sub>i</sub> are not welcome in this house.
- (13) a. \*Some  $\left\{ \begin{array}{l} \text{man and women} \\ \text{women and man} \end{array} \right\}$  were having an awful argument.  
 b.  $\left\{ \begin{array}{l} \text{Some man and some women} \\ \text{Some women and some man} \end{array} \right\}$  were having an awful argument.

In (8)–(11), the non-ellipsed versions are themselves ill-formed, showing, among other things, the futility of trying to handle the standard difficulty posed by symmetrical predicates in peripheral node-raised constructions by means of some ‘integration’ mechanism associated with displacement, as has been suggested occasionally in recent work; the problem in the cases illustrated is of the same sort, and no displacement can be even remotely plausible as the source. (12), based on Heycock and Zamparelli’s example (125), and (13), present a problem for the LBE account of a rather different order: here the question is one of blocking an ellipsis which, on purely structural grounds, does not appear to provide any basis for such a block, other than that the result is ill-formed.

The moral is that once the data to be explained under an ellipsis-based analyses include anything beyond simplest-case examples such as (1)c, the empirical advantage routinely claimed for such analyses in the literature arguing for LBE accounts of coordination largely vanishes. The phenomena illustrated above make clear the need to consider other possibilities, e.g., that structures in which nominal structures *appear* to be conjoined under a singular determiner are best analyzed along precisely those lines. Thus, if *That ill-suited man and woman have never been civil to each other in public* cannot be represented as

- (14) That ill-suited man and ~~that ill-suited~~ woman have never been civil to each other in public.

then the source of *that man and woman have never been civil to each other in public* cannot plausibly be taken to be

- (15) That man and ~~that~~ woman have never been civil to each other in public.

## 2.2 Nonconstituent coordination

### 2.2.1 Negative quantification

Consider next the data in (16) in light of the analysis demanded by the LBE analysis of nonconstituent coordination:

- (16) Terry said nothing about Robin on Thursday or (about) Leslie on Friday.

Such examples are interpretable exclusively as a coordination of negations: (16) is true just in case Terry said nothing about Robin on Thursday and Terry said nothing about Leslie on Friday. We note further that the strings *Robin on Thursday or Leslie on Friday* and *about Robin on Thursday or about Leslie on Friday* are nonconstituents. Hence they *must* arise, on the LBE view, by ellipsis.

- (17) a. [ $\zeta$  Terry said nothing about Robin on Thursday] or [ $\varrho$  ~~(Terry) said nothing about~~ Leslie on Friday]. [ $\neg\zeta \vee \neg\varrho$ ]  
 b. [ $\zeta$  Terry said nothing about Robin on Thursday] or [ $\varrho$  ~~(Terry) said nothing~~] [ $\neg\zeta \vee \neg\varrho$ ] about Leslie on Friday.

But while the interpretation of these sentences permits only the conjunction-of-negations reading (as indicated in the formulæ attached to each of the abbreviated DOM representations), the denotation of the ‘source’ sentences, corresponding the meaning of (17) without the strikethroughs is precisely the *disjunction* of negations which we identified as unavailable for the meaning of (16). The interpretation of (16) reflects something very much like the De Morgan equivalence  $\neg(\zeta \vee \varrho) \equiv \neg\zeta \wedge \neg\varrho$ , which of course would follow if the negation operator were both able and required to scope directly over some grammatical object corresponding to the disjunction of the PP PP or NP PP sequences in (16). But of course, the LBE approach exists precisely in order to deny that such coordination is the source of this and similar examples.

We note in the first place that the proposal in Crysmann 2003 imposing token identity on ellipsed dependents (as vs. ellipsed heads) gets no traction at all in dealing with the problem posed by (16). Crysmann motivates this asymmetrical treatment on the basis of the data he gives in his examples (18)–(20) (my renumbering):

Thus, in semantic terms, sharing of heads differs quite drastically from sharing of dependents, where token-identity of cont values is necessary to derive the correct interpretation:

- (18) a. Few men drink and smoke.  
 b.  $\not\exists$  Few men drink and few men smoke.  
 (19) a. Few men gave Mary a book on Friday and a record on Saturday.  
 b.  $\not\exists$  Few men gave Mary a book on Friday and few men gave Mary a record on Saturday.  
 (20) a. I gave few men a book on Friday and a record on Saturday.  
 b.  $\not\exists$  I gave few men a book on Friday and I gave few men a record on Saturday.

Without token-identity of CONT values, we would give the above sentences in a. an interpretation equivalent to b., whereas structure-sharing will ensure that the sets denoted by few men are identical across the two conjuncts in the a. sentences, while they may be disjoint in the corresponding sentences in b...[Dependents] observe a stronger restriction [than heads], involving token-identity of the domain objects across all conjunct daughters. This latter requirement is sufficient to derive the effect of obligatory coreference of shared dependents.

(pp. 51, 62). Since the denotation of the null quantifier *nothing* is constant to exactly the same degree as that of *a book* in *I gave a book to Robin on Tuesday and to Terry*

on Thursday on the reading in which the book Robin received is distinct from the one that Terry received, it is difficult to see how Chrysmann’s restriction on identity of content can possibly account for the unavailability of the ‘disjunction of negatives’ interpretation. Chrysmann’s own efforts to handle this kind of *give a book* example of NCC involves recourse to a semantically extremely vague concept of ‘abstract notion’ or ‘abstract referent’, with not even a preliminary characterization of what class of semantical objects is denoted by such labels, and hence no way of determining the substantive *content* of Chrysmann’s proposal. It seems sufficiently self-evident, however, that in whatever sense *a book* is ‘token-identical’ in the two different conjuncts in this kind of example, the tokens of *nothing* in the required source for(16) are a fortiori, a point that Beavers and Sag (2004) themselves make.

Beavers and Sag certainly do not ignore the problem posed by Chrysmann’s examples, but neither do they adopt his proposals as I’ve cited them. Rather, in connection with the seemingly obligatory nature of their Quantifier Merger operation in (18)–(20), they comment that ‘we tentatively suggest that this can be regarded simply as a preference for constituent coordination’. But that hardly be the solution for the obligatory wide-scoping of negation over disjunction (with the attendant De Morgan interpretation) in (16), since there *is* no constituent coordination available, as already discussed. It has been suggested that the Beaver & Sag operation of ‘Quantifier (Q-) Merger’ might be able to save the ellipsis analysis here. Formally, Q-Merger is defined in AVM notation as follows:

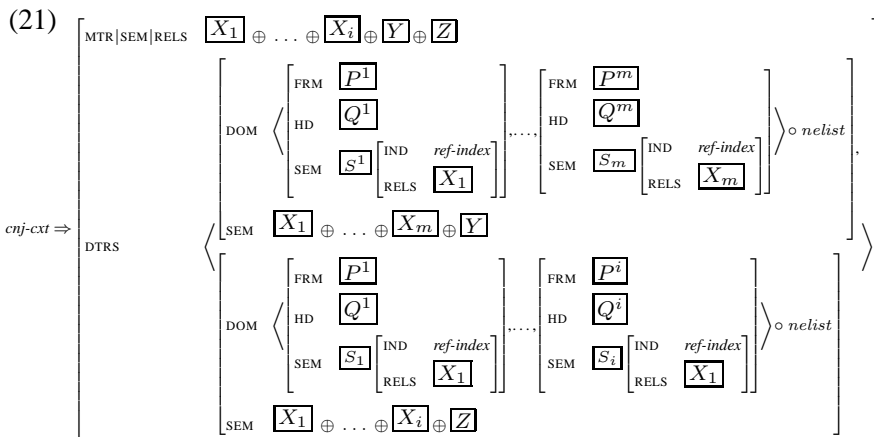

The problem that Q-Merger faces can be schematically summarized in (22):

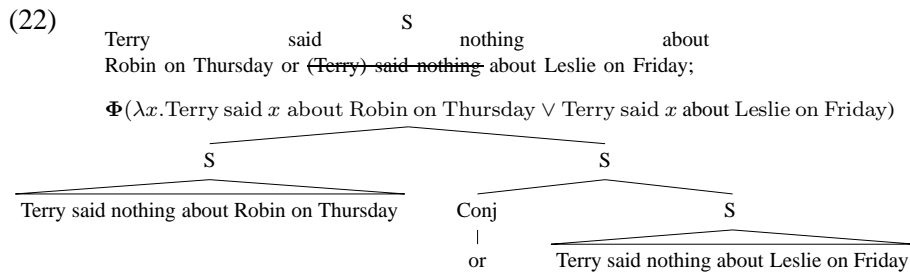

In a nutshell, Beaver and Sag would need to posit some variable-like element corresponding to the quantifier in the two conjuncts and then let the conjunction take scope



and then bind the variables over the whole coordinate structure either by an analog of the lambda operator or by somehow binding the variable(s) directly by the quantifier. There is not the faintest hint within the MRS markup language that Beaver and Sag assume about how to implement such a translation, because there is nothing analogous to lambda abstraction in MRS. But that particular difficulty is only the beginning of the trouble facing OQM. Let's assume that something along those lines could be worked out. Certainly in an algebraically well-defined representation language such as RSRL, lambda abstraction can be simulated, and in the associated syntax/semantics interface definition, aka Lexical Resource Semantics, lambda abstraction is the default formalism for set definition. So we may assume, for the sake of argument, that something like the Beaver/Sag analysis could be reconstructed as in LRS. Then this analysis at the very least requires that quantifiers appearing within conjuncts be able to scope out of conjuncts, a very dubious assumption. Consider the example from Sabbagh 2007:

- (23) a. Some nurse gave a flu shot to, and administered a blood test for, every patient who was admitted last night.  
 b. Some nurse gave a flu shot to ~~every patient who was admitted last night~~, and administered a blood test for every patient who was admitted last night.
- (24) Some nurse gave a flu shot to every patient who was admitted last night, and administered a blood test for every patient who was admitted last night.

Right Node Raising, as in (23)a, allows the quantifier in the 'raised' material to outscope the coordination; but when the quantifiers are overt, this scoping is not available. Any proposal in which phonologically covert quantifiers reflected scoping possibilities unavailable in the corresponding cases with phonetically realized quantifiers would be suspicious in the extreme, but that is what the situation would have to be for there to be any chance of 'Quantifier Merger', however implemented, to account for the negative quantifier scope data in (16).

More generally, Quantifier Merger 'kicks in' only when quantifier meanings are not just identified across conjuncts, but one of the corresponding quantifiers is ellipsed as well. Examination of this claim reveals a remarkable coincidence: in just those cases where a quantifier appears *phonetically* outside a coordination, it is allowed, by a special 'handwritten' specification of the mother's SEM value, to act combinatorially as though it were indeed outside that coordination. This is of course completely fortuitous on the assumption that the quantified NP occurs within both conjuncts, since there is no structural reason, no functional linkage whatever in HPSG's feature architecture, between the phonological form of the quantifier on the one hand and its scoping possibilities on the other.<sup>1</sup> But Q-Merger in effect builds that massive coincidence into the grammar, as a kind of 'last resort stipulation', since if two distinct generalized quantifiers were to structure-share the same BODY specification, we would wind up with a kind of multidominance in the MRS tree structure—a violation of the principle constraint imposed on such MRS scoping configurations. The burden of proof inherently assumed by such a proposal makes it considerably less attractive than the

<sup>1</sup>There is no reason in principle, for example, why one could not have written Q-Merger so that the SEM on the mother was the same even in the absence of ellipsis, so that *I said nothing to Robin on Friday* or *I said nothing to Leslie on Sunday* had the same reading as (16), which is manifestly *not* the case.

position which motivates the scoping in the two different cases on the assumptions that the structures involved are, indeed, fundamentally different.

But the most problematic aspect of any account of (16) along these lines is that it fails completely to account for the fact that, in the absence of significant informed introspection, this sentence appears to *preclude* an interpretation reflecting the structural components which are the input to the coordination—that is, where the sentence is interpreted as a disjunction of negated propositions. Q-merger, at least on the most recent version of LBE, in Chaves and Sag 2009, would have to be optional, since ellipsis is completely nondeterministic, the result of alternative assignments of substrings of the input daughters’ COM lists to variables in the coordination construction schema. So what happened to this interpretation? One suggestion that came to my attention in the feedback on the abstract submission for the Conference presentation version of this paper was based on the possibility that this essentially unavailable reading was somehow ‘preempted’, along the following lines. In the case of a sentence such as

- (25) a. Nothing bothers Robin or annoys Leslie.  
 b.  $\neg\exists x.\mathbf{bother}(\mathbf{robin})(x) \vee \mathbf{annoy}(\mathbf{leslie})(x)$   
 c.  $\neg\exists x.\mathbf{bother}(\mathbf{robin})(x) \vee \neg\exists w.\mathbf{annoy}(\mathbf{leslie})(w)$

we have in principle two sources, which should give rise to two different readings. On one of them, *nothing* outscopes the the disjunction, as per (25); on the second, *or* outscopes negation, yielding a reading along the lines of (25)b. As it happens, however, the second of these readings is for most, if not all speakers, simply unavailable; there is no ambiguity, and the only reading (on the quantificatory interpretation of *nothing* is (25)a. On the structure

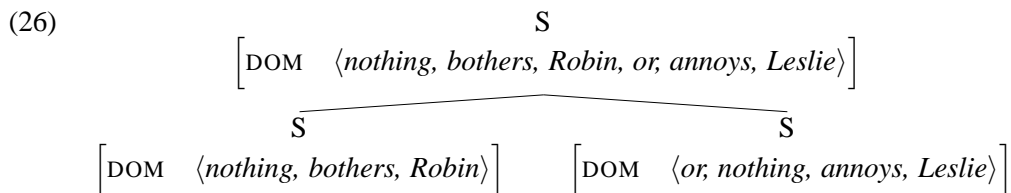

we expect to get a reading of the form  $\neg\varphi \vee \neg\psi$ , given the semantics of the input sentences. The suggestion I want to respond to here is that this missing reading is ‘preempted for performance reasons’, with the following interesting comment:

I for one find it quite reasonable that when a conjunction can be parsed by direct coordination, without ellipsis, then that parse is highly preferable when compared to an elliptical parse UNLESS there are contextual or semantic factors that make the direct parse odd.

giving as an example

- (27) a. Two trees were cut down by me in 1986, and by my wife in 1999.  
 b. Two trees were cut down by me in 1986, and by my wife in 1999.

But the point is that (16) *has no other source than ellipsis on the assumptions in the literature I’m speaking to*. If, as assumed in this literature, coordination only combines constituents as defined by the various schemata, or type constraints on headed

structures, then (16) *must* be derived from a sole source of the form (17)b. Hence, in contrast to (25)a, there is in principle *no* way to obtain the virtually exclusive reading for the examples (16) from the semantics of any candidate input structures. In order to obtain the different reading associated with the input disjunction of negations, it would be necessary first of all to carry out ellipsis, and then apply a rule of Q-Merger which, as I've already discussed, has a very obscure formal basis for the necessary logical algebraic operations, and which moreover contradicts the observed pattern of quantified NP interpretation from within conjuncts. But even this isn't enough: a convincing, independently motivated account must be given to make it plausible that the disjunction-of-negations reading is somehow pragmatically so inaccessible that it is suppressed by virtually every ordinary speaker of English I've consulted. Finally, it should be noted that none of this will account for the fact that for many speakers, (28) is perfectly well formed, but literally unlicensable on ANY reading, from (4)a:

- (28) a. I said nothing to Robin on Thursday nor (to) Leslie on Sunday.  
 b. I said nothing to Robin on Thursday nor ~~(I) said nothing to Leslie on Sunday~~

The source of (28)a, (28) b, corresponds to a completely impossible string when supposedly optional ellipsis occurs. Nor is there any way to use (4) to obtain (28) on the basis of the acceptable version of (28)b incorporating neg-fronting (*I said nothing to Robin on Friday nor did I say anything to Leslie on Sunday*, with a host of completely ad hoc item-by-item replacements requiring a special construction that would have, I think, minimal credibility. Moreover, treating *nor* as a 'prosodic variant' of *or* under the circumstance, another possible story within the LBE approach, demands that the conditions on this variation be fully spelled out, at a level of detail I have yet to see in any LBE analysis.

I therefore think it fair to say that the burden of proof in this case very clearly rests on the shoulders of whoever actually believes that there is a coherent, explicit LBE story about examples such as (16) that accounts for the facts.

### 2.2.2 Symmetrical predicates

The fundamental inadequacy of Optional Q-Merger to handle data such (28) emerges clearly when we turn from negative quantification to what *appears* to be a comparable phenomenon involving symmetrical predicates quantification. In the case of (29), for example, we find a flagrant mismatch between the meaning of (29)a on the one hand and that of its non-ellipsed 'sources' in (29)b–c on the other:

- (29) a. I said the same thing to Robin on Thursday and (to) Leslie on Friday.  
 b. I said the same thing to Robin on Thursday and ~~(I) said the same thing to Leslie on Friday.~~  
 c. I said the same thing to Robin on Thursday and ~~(I) said the same thing to Leslie on Friday.~~

To the extent that a context can be provided in which the source sentences in (29)b–c make sense, synonymy between these examples on the one hand and (29)a on the other is in no sense entailed, though it might be inferred if, coincidentally, *the same thing* in the first clausal conjunct and *the same thing* in the second clausal conjunct happen to be identical to each other. But given a situation in which you met twice with Robin, once

on Monday and once on Thursday, and twice with Leslie, once on Tuesday and once on Friday, we can easily take (29)b–c to mean that you said  $X$  to Robin on Monday and then said  $X$  to him or her on Thursday, and you said  $Y$  to Leslie on Tuesday and then said  $Y$  to him or her on Friday, with  $\llbracket X \rrbracket \neq \llbracket Y \rrbracket$ . In (29)a, on the other hand, there is no other interpretation apart from the one in which  $\llbracket X \rrbracket = \llbracket Y \rrbracket$ . Here again, the predictions of the ellipsis approach fall wide of the mark.

Things are no better when we consider cases such as (1)b. On the ellipsis approach, we need to analyze (30)a along the lines of (30)b:

- (30) a. Robin reviewed, and Leslie read, the same book.  
 b. Robin reviewed ~~the same book~~, and Leslie read the same book.

Consider the following situation: ten years ago, Robin reviewed some book  $B_1$  and Leslie read some book  $B_2$ . Robin’s job reviewing dozens of books a year, and Leslie’s habits as an avid reader with a poor memory, has brought about a situation in which Robin writes a second review of  $B_1$ , and Leslie rereads  $B_2$ . Under these circumstances, the ‘source’ sentence reflected in (30)b would be appropriate—but (30)a would not be. The latter can only mean that there was a particular book such that Robin reviewed that book and Leslie read it. Again, the ellipsis analysis fails to capture the facts.

The obvious move in this case is to take the position that ‘in for a penny, in for a pound’, and extend the OQM analysis, flawed as it may be, to these cases as well. But that move is blocked under Beaver and Sag’s own assumptions, which include the (well-motivated) caveat that OQM can only apply to generalized quantifiers. It turns out that this restriction prevents any application of OQM to the cases in (29).

Barker 2007, whose semantics for *same* represents the most explicit and fully developed analysis of symmetrical predicates to day, notes a proof given in Keenan 1992 which provides an immediate test for generalized quantifier status. As Barker summarizes Keenan’s analysis, the crucial concept in the proof is reducibility, where the reducibility relation *Reducible* holds between an NP sequence and some generalized quantifier(s) just in case the former can be decomposed into (some combination of) the latter ‘an NP sequence is REDUCIBLE if it can be decomposed into separate generalized quantifiers that accurately reflect the truth conditions on the original’ (p.412). The probe that Keenan proves works as follows: if both  $E_1$  and  $E_2$  are generalized quantifiers, where each contains a transitive verb  $V$ , and if whenever  $\llbracket V \rrbracket = A \times B$  for two arbitrary sets  $A, B$ , then  $\llbracket E_1 \rrbracket = \llbracket E_2 \rrbracket = \mu \in 2$ , then, iff  $E_1$  has the same truth conditions as  $E_2$  under *all* valuations of  $\llbracket V \rrbracket$ ,  $Reducible(E_1) \wedge Reducible(E_2)$ . Since for

- (31) a. Robin and Leslie read the same two books.  
 b. (Both) Robin and Leslie read exactly two books

we have, for  $\langle R( Robin), L( Leslie), \dots \rangle \times \langle b_1 \dots b_n \rangle = \langle R, b_1 \rangle, \dots, \langle R, b_n \rangle = \langle L, b_1 \rangle, \dots, \langle L, b_n \rangle$ , a valuation of  $\mathbf{o}$  for both of the sentences in (31) when  $n \neq 2$  and a valuation of  $\mathbf{1}$  when  $n = 2$ . Therefore, to be reducible, the same result must hold when  $\llbracket read \rrbracket = \{ \langle R, b_1 \rangle, \langle R, b_2 \rangle, \langle L, b_3 \rangle, \langle L, b_4 \rangle \}$ , but obviously it does not: (31)b is true, but (31)a is false. It follows (31)a cannot be represented as a logical expression

via any generalized quantifier or combination of generalized quantifiers. In the case of an example such as (32), therefore, we must assume semantic identity between two tokens of a scoping element which does not have the semantics of a generalized quantifier:

(32) I told the same joke to Robin on Friday and Leslie on Sunday.

Recall, however, that Beavers and Sag explicitly restrict OQM to generalized quantifiers. The motivation they provide for this restriction is the existence of examples such as

- (33) a. The waiter managed to evict the customers diplomatically and ~~evict~~ the staff authoritatively.  
 b. [The waiter forced the customers ~~to leave quietly~~] and [the manager persuaded the staff] to leave quietly.

The point of such examples can be seen by considering what the effect of optional semantic identity in the ellipsed token of *evict* in (33)a would be. According to the Beavers and Sag 2004 statement of OQM, the EPs in the SEM|RELS specification in (34)a and b would be equated. The two separate tokens of *evict* in *The waiter managed to evict the customers diplomatically and to evict the staff authoritatively* would have a partial partial description

$$(34) \quad \text{a.} \quad \left[ \begin{array}{l} \text{SYN} \\ \text{SEM|RELS} \end{array} \left[ \begin{array}{l} \text{HD} \quad \textit{verb} \\ \text{FRM} \quad \textit{evict} \\ \text{ARG-ST} \quad \langle \boxed{3} \cdot \boxed{1} \cdot \boxed{4} \cdot \boxed{2} \rangle \\ \left\{ \begin{array}{l} \textit{evict\_rln} \\ \text{ARG1} \quad \boxed{1} \\ \text{ARG2} \quad \boxed{2} \end{array} \right\} \end{array} \right] \right] \quad \text{b.} \quad \left[ \begin{array}{l} \text{SYN} \\ \text{SEM|RELS} \end{array} \left[ \begin{array}{l} \text{HD} \quad \textit{verb} \\ \text{FRM} \quad \textit{evict} \\ \text{ARG-ST} \quad \langle \boxed{3} \cdot \boxed{1} \cdot \boxed{4} \cdot \boxed{2} \rangle \\ \left\{ \begin{array}{l} \textit{evict\_rln} \\ \text{ARG1} \quad \boxed{1} \\ \text{ARG2} \quad \boxed{3} \end{array} \right\} \end{array} \right] \right]$$

where the lexical entries for *customers* and *staff* respectively are, in simplified but adequate representation, given in (35):

$$(35) \quad \text{a.} \quad \left[ \begin{array}{l} \textit{customers\_rln} \\ \text{LBL} \\ \text{ARG0} \end{array} \left[ \begin{array}{l} \boxed{0} \\ \boxed{2} \end{array} \right] \right] \quad \text{b.} \quad \left[ \begin{array}{l} \textit{staff\_rln} \\ \text{LBL} \\ \text{ARG0} \end{array} \left[ \begin{array}{l} \boxed{0} \\ \boxed{3} \end{array} \right] \right]$$

The only way that we can equate the [SEM|RELS] values of the ellipsed and nonellipsed versions of *evict* in (34) is if  $\boxed{2} = \boxed{3}$ —in other words, if the waiter evicted just those individuals corresponding to the two descriptions ‘staff’ and ‘customers’. The result would be paraphrasable as something like ‘The waiter managed to diplomatically and authoritatively evict those of the customers who were also employees of the restaurant’, clearly not an available reading. If we alter the adverb in the conjunct subject to ellipsis so that *rudely* replaces *authoritatively*, we obtain a reading paraphrasable as ‘The waiter managed to diplomatically and rudely evict those of the customers who were also employees of the restaurant’, containing a contradiction again absent from the interpretation of *The waiter managed to evict the customers diplomatically and*

*the staff rudely*. Nor can we rule out such intersective identifications of indices, since clearly they are necessary on the most natural reading of *Robin is my friend and colleague*.

We see this not only with VPs; predicative NPs present the same problem:

- (36) Robin's house is  $\left\{ \begin{array}{l} \text{a real bastard} \\ \text{the worst place in the world} \end{array} \right\}$  for people with cars to find parking around and people on foot to get to safely.

Here, the semantic analysis defended in Levine and Hukari 2006 for *easy* adjectives extends directly to members of the class of NPs which has a similar semantics and argument/gap relation between subjects and an internal object position. In terms of this analysis, *people with cars* is an argument of the head noun *a real bastard*, which denotes the relation that holds between people with cars on the one hand and those people's task of finding parking around Robin's house on the other. Clearly, the same semantic issues that arise in connection with (33) cannot be avoided here either, unless optional semantic identity is restricted to generalized quantifiers.<sup>2</sup>

It follows that if *same* is part of an ellipsis target  $T'$  under (partial) identity with a DOM substring  $T$ , the SEM values of the two tokens of *same* do not have the option of semantic identity under OQM. Thus, the only alternative is that the semantics of the overt token of *the same joke* and that of the ellipsed version are nonidentical. But this alternative fails also, predicting as it does that (32) has the same meaning as (37):

- (37) I told the same joke to Robin on Friday and I told the same joke to Leslie on Sunday.

In the terminology of Carlson 1987, this sentence has access only to the *external* sense of *same*, reflected in the sentence *I told the same joke to Robin on Friday*, in which the interpretation requires there to be some salient joke in the discourse background which is identical to the one I told Robin. This sense of *the same* is fundamentally different from that of the 'internal' reading reflected in (33). The difference emerges clearly in examples like (38):

- (38) a. I'll tell the same joke to Robin on Thursday and (I'll) tell the same joke to Leslie on Sunday.  
 b. I'll tell the same joke to Robin on Thursday and to Leslie on Sunday.

---

<sup>2</sup>Note that these considerations also have a bearing on just how we are to interpret the ontological status of the DTRS specifications given in the OQM template in (21). The content of the SEM specifications assumed in Beavers and Sag 2004 is represented by MRS structures, of the sort described in Copestake et al. 2006, and hence could, in principle, correspond to either (i) underspecified objects, where the tokens of generalized quantifiers in each of the conjuncts have not been scope-resolved (Copestake et al. 2006, p. 293), or to (ii) fully scope-resolved MRSs, in which the LBL, ARG0, RESTR and BODY values are equated. The critical issue is what happens when BODY specifications are equated. It would *appear* that if in the case of an unellipsed conjunction *I said something nice to Leslie and I said something critical to Terry*, we equate the HANDLE value of the body of *something* in the first conjunct to the LBL value of *said* (as would be the case in the sentence *I said something nice to Leslie*), and likewise for the second conjunct, then equating the two BODY values would also require equating the arguments in the two EPs corresponding to the different tokens of *said*, leading again to a completely incorrect interpretation. Apparently, then, we must take the representations in the SEM|RELS specifications on each of the conjunct daughters to not have undergone scope-resolutions.

Assume that there no reference in prior discourse has been made to any joke. Then (38)a is distinctly anomalous, illustrating the fact that an existential presupposition accompanies *the same joke* when there are overt tokens of this NP. No such presupposition holds in the case of (38)b. It places an unacceptable burden on credulity to claim any kind of plausibility for a claim that somehow the simple fact of prosodic silence in place of an overt pronunciation has the effect of cancelling a presupposition introduced by both tokens of some lexical item which undergoes ellipsis.

There are other strong reasons noted by Barker for keeping the semantics of internal and external *same* NPs separate. Unifying the two, as in Dowty 1985, requires that one introduce two free variables, one identifying a salient relation  $R$  and the other a ‘comparison class’, so that, on the external reading, with  $\llbracket \textit{same} \rrbracket = \lambda N \lambda x \exists f \forall c \{x\} = f(N) \wedge c < C : R(x)(c)$ . Thus, in the case of *Robin read the same book*,  $C$  is the prominent set of individuals identified in previous discourse, with  $\llbracket N \rrbracket = \llbracket \textit{book} \rrbracket = \mathbf{book}$  and  $f$  a choice function that picks out a member of the set of books, and  $R = \llbracket \textit{read} \rrbracket = \mathbf{read}$ . *The same book* is then the (singleton) set containing the individual that  $f$  maps  $\mathbf{book}$  to such that every member of the comparison set—whatever it is—is in the  $R$  (in this case,  $\mathbf{read}$ ) relation to that individual. In the case of *Robin and Leslie read the same book*, the comparison set is  $\llbracket \textit{Robin and Leslie} \rrbracket = \mathbf{robin} \oplus \mathbf{leslie}$ , and so on. But what such an analysis at first appears credible, even elegant, Barker shows that it cannot be sustained.

In the first place, as Barker notes, if a comparison set and a particular relation are available from context for the interpretation of *same*, then we would expect that any relevant comparison sets and relations which were salient in prior discourse should yield a reading; but this is not the case; e.g. we have *The men discussed a house. John read the same book*, where if  $C = \mathbf{men}$  and  $R = \mathbf{discuss}$ , then there should be a reading in which John read a certain book which each of the men had discussed; but this reading is not available. Thus, the idea that *same* implicates some contextually determined relation is dubious in general. Crucially, however, while  $R$  can be contextually determined when the comparison set  $C$  differs from the denotation of the relevant constituent  $K$  in the sentence that is a coargument of the verb that *the same N* is an argument of (e.g., we can have *The men discussed a book, and John had read the same book*), this is not possible when the comparison class is defined by  $K$ . For example, in the case of *Everyone discussed a book, and Robin and Leslie read the same book*, the sentence can only mean that there was some book that everyone discussed, but when the comparison class is *Robin and Leslie*, the relation  $R$  is not the book that everyone discussed, but some book that both Robin and Leslie had both read. There is in other words, as Barker notes, a correlation between  $R$  and  $C$  when  $C$  is the comparison set that is certainly not logically necessary, but which always appears to hold.

We must conclude, then, that we cannot obtain the semantics of (32) by ellipsis under semantic non-identity between the ellipsed and non-ellipsed tokens of *the same joke*, while, under Beavers and Sag’s own hypothesis—itsself reflecting the conditions imposed by data such as (33) and (36)—we cannot account for (32) by Optional Quantifier Mergers. But the specific mismatch in meanings available between ellipsed and non-ellipsed variants of NCC involving symmetrical predicates such as *same* is precisely the same as that involving negative generalized quantifiers such as *nothing*; in both cases, we have a scopal operator of some sort scoping over the coordination to

yield an interpretation which corresponds to a fundamental set of truth conditions from what we encounter in the non-ellipsed version. It is thus clear that Optional Quantifier Merger represents a misguided approach to solving the problem posed by NCC, and that the evidence strongly suggests that we look elsewhere for a solution.

### 2.3 Unlike category coordination

The use of ellipsis to eliminate the unlikeness of apparent unlike category coordination (UCC), as discussed above in connection with (7)c, again leads to severe mispredictions once one looks beyond the very narrow class to which the LBE literature restricts itself, as in e.g. Beavers and Sag 2004, Chaves 2007, Chaves and Sag 2009. Interestingly, the recognition of difficulties with an approach based exclusively on (4) was the apparent basis of the analysis in Chaves 2006, in which the coordination of unlikes in absolutive constructions is treated as an instance of a network of special constructions which in effect mimic the effect of (4), but avoid certain mispredictions which would otherwise attend a straightforward application of the usual LBE technology (e.g., the problem posed by *Neither tired nor in a hurry, I decided to walk and save the bus fare*, where the source for the ellipsis, *Neither tired ~~I decided to walk and save the bus fare~~ nor in a hurry I decided to walk and save the bus fare*, yields ill-formed results.) Chaves' key idea is that the effect of these interacting constructional possibilities supplies an inaudible copula to convert two apparently distinct category descriptions in a structure [XP Conj YP] into a coordination of VPs [<sub>VP</sub> [<sub>VP</sub> *be* XP] Conj [<sub>VP</sub> *be* YP]]<sub>VP</sub>, an approach similar in spirit to (4) but relying instead on stipulated inaudibilia. Apart from this minor (and, as I argue directly, ineffective) addendum to the elliptical analysis of UCC, however, the basic account of such phenomena is just what is summarized in (7)c.

In fact, there is an impressive range of constructions which highlight the empirical inadequacy of the ellipsis approach. I present a brief survey of these cases in this section; below, we show how they can be captured in a fully general way using a particular TLCG formalism.

**Ellipsis-incompatible topicalized coordinations** In order to account for cases such as (39)a via LBE, something like a RNR analysis is required:

- (39) a. Rich and a Republican, Robin definitely is t.  
 b. Rich ~~Robin definitely is~~ and a Republican Robin definitely is t.

Such cases are amenable to the LBE analysis, however, only because the elements of the coordination are independently sortable over the two tokens of the extraction source clause, *Robin definitely is* (39). This state of affairs does not hold generally:

- (40)  
 a. (Both) poor and a Republican, you can't possibly be t.  
 b. (Both) [poor ~~you can't possibly be~~ t] and a Republican you can't possibly be t.  
 c. (Both) poor you can't possibly be t and a Republican you can't possibly be t.

The 'source' sentences for the coordination correspond, under *and* conjunction, to a very different meaning, where the crucial interpretation of *poor and a Republican* as a sum of properties is literally unavailable. Another example displaying the same



analytic problems is given in (41)a, with the forced analysis in (41)b under the Chaves and Sag 2009) RNR scenario:

- (41) a. Dead drunk  $\left\{ \begin{array}{l} \text{but} \\ \text{and yet} \end{array} \right\}$  in complete control of the situation, no one can be t.  
 b. Dead drunk ~~no one can be t~~  $\left\{ \begin{array}{l} \text{but} \\ \text{and yet} \end{array} \right\}$  in total control of the situation, no one can be t.

The only practical solution within the assumptions of the LBE literature for the difficulty these data present—in particular, the axiom that unlike categories do not actually coordinate—appears to be a brute-force analysis in which one simply declares the coordination of AP and PP an AP—the sort of approach which, as illustrated in Chaves 2006, is increasingly typical for constructional approaches. Whatever one thinks of this approach—which essentially generalizes the kind of rule letting an NP dominate both an NP and an S from Sag et al. 1985, and which Bayer (1996) has I think effectively shown to be empirically quite unsatisfactory—the LBE approach on its own does a very poor job of addressing the full range of unlike category coordinations which appear in extraction contexts.<sup>3</sup>

One approach that might be taken, of course, is that these data, though apparently good to a large number of speakers, really are ill-formed, and indeed the reduced acceptability of topicalized UCCs has been asserted in Beavers and Sag 2004. But there is no reason to suppose that this assessment reflects the actual status of such examples generally. UCC examples of the sort that Beavers and Sag claim to be defective are cited as unexceptionable in articles appearing in journals of record, e.g., Peterson 2004, and I personally have yet to encounter a native speaker of English who registered the slightest discomfort in the of a ‘spontaneous’ utterance of any of these examples, or expressed negative judgments on, say, *You can be poor and healthy, and someone who’s very clever or very good could wind up being poor and highly respected—but poor and a REPUBLICAN, NO ONE can be.*

**Ellipsis-incompatible pseudocleft coordinations** We turn now to the English pseudocleft construction—a somewhat mysterious pairing of what seems to be a headless relative with a predicate, linked syntactically by a copula:

- (42) What<sub>i</sub> Robin wanted t<sub>i</sub> was a new outboard motor.

For present purposes, the importance of the pseudocleft is that the complement of the copula—the focal constituent, as it is often called—can take the form of an unlike category conjunction:

- (43) a. What you cannot become (simultaneously) is highly intelligent and yet a raving fundamentalist.  
 b. What you cannot become is both highly intelligent and yet a raving fundamentalist.

<sup>3</sup>*Become* takes AP but not PP as a complement. But if [AP and PP] can be analyzed as AP, we incorrectly predict that \**John became totally irrational yet in complete control of the situation.* is grammatical. This kind of example seriously undercuts the viability of the stipulative approach to UCC in question.

A standard LBE analysis for such cases based on (4) corresponds to semantically incongruous interpretations arising from the source sentences:

- (44) a. What you can't (simultaneously) become is highly intelligent and yet ~~what you can't simultaneously become~~ is a raving fundamentalist.  
 b. What you can't simultaneously become is highly intelligent and (yet) ~~is~~ a raving fundamentalist.  
 c. What Robin was, clearly, was both highly intelligent and ~~was~~ a raving fundamentalist  
 d. What Robin was, clearly, was highly intelligent yet ~~was~~ a raving fundamentalist

The first of these simply does not mean what the ellipsed version means, along lines already discussed. The second, third and fourth just seem severely ill-formed in some way unless the notated ellipsis occurs. It is, moreover, straightforward to show that no application of Chaves' 'ghost copula' solution can work in for such data. Pseudoclefts thus constitute yet another major empirical challenge to the LBE approach and its extensions.

**Ellipsis-incompatible posthead nominal modifier coordinations** Posthead nominal modifiers constitute yet another predictive failure for the LBE.

As an example, consider cases such as (45):

- (45) a. [<sub>NP</sub> Politicians [<sub>VP</sub> keeping a low profile] and [<sub>PP</sub> with plenty to hide]] are the ones we should be investigating.  
 b. [<sub>NP</sub> People [<sub>PP</sub> totally into themselves] and [<sub>VP</sub> only thinking of their own careers]] seem to be in the vast majority these days, I fear.

Examples such as these are extremely common, but it's not at all clear how an LBE account of them can be given. The obvious sources are structures such as (46):

- (46) Politicians keeping a low profile and ~~politicians~~ with plenty to hide are the ones we should be investigating.

But this approach clearly will not work in cases such as

- (47) a. [<sub>NP</sub> Novels [<sub>AP</sub> full of dramatic conflict] but [<sub>PP</sub> with meticulously accurate historical detail]], such as this one, are quite unusual.  
 b. [<sub>NP</sub> Novels [<sub>AP</sub> full of dramatic conflict] but ~~novels~~ [<sub>PP</sub> with meticulously accurate historical detail]], such as this one, are quite unusual.  
 c. \*Novels full of dramatic conflict but novels with meticulously accurate historical detail, such as this one, are quite unusual.

(47)c is out-and-out impossible, but the analysis in (48)a, while giving rise to an acceptable form, is no more satisfactory:

- (48) a. Novels full of dramatic conflict ~~are quite unusual~~, but ~~novels~~ with meticulously accurate historical detail, such as this one, are quite unusual.  
 b. Novels full of dramatic conflict ~~are quite unusual~~, but novels with meticulously accurate historical detail, such as this one, are quite unusual.

And even the expedient of creating a completely novel construction with the AP and PP ‘coerced’ into clausal shells, as in (49), fails:

- (49) a. Novels [<sub>s</sub>  $\emptyset$ <sub>which are</sub> full of dramatic conflict but  $\emptyset$ <sub>which are</sub> with meticulously accurate historical detail], such as this one, are quite unusual.  
 b. \*Novels which are full of dramatic conflict but which are with meticulously accurate historical detail, such as this one, are quite unusual.

Again, none of the various expedients that LBE routinely appeals to correspond to anything remotely like the correct representations for the sentence in (47)a. And obviously, things only get worse in the case of a slightly more elaborate coordination such as *Novels both full of dramatic conflict and with meticulously accurate historical detail, such as this one, are quite unusual*.

## 2.4 A putative CG misprediction

Finally, something should be said about the much-invoked datum (50) due to Crysmann (2003) often taken to undermine decisively any categorial account based on coordination of ‘partial constituents’:

- (50) John gave Mary a book, and to Peter a record.

(p.52). Beavers and Sag argue that

In CCG the composed categories *Mary a book* and *to Peter a record* would not be acceptable candidates for coordination since they have two related but distinct categories  $(S \setminus NP) \setminus (S \setminus NP/NP/NP)$  and  $(S \setminus NP) \setminus (S \setminus NP/NP/PP)$  respectively. But an ellipsis-based approach again reduces these to simple VP (or S) coordination, predicting their acceptability. (p.57)

Whatever may have been the case so far as 1980s-style CCG is concerned, however, there is no basis for taking (50) to be a challenge for contemporary type-logical avatars of categorial grammar.<sup>4</sup> The key element in the proof, proposed in Morrill 1994 and expanded and applied in Bayer 1996, is the enrichment of the inference rules of the type logic with meet and join combinators—*independently* justified *outside* any applications to coordination, as Bayer shows, by cases where a single item reflecting morphological neutralizations of feature conflict appear in extraction ‘landing sites’ which are incompatible with the requirements imposed by connectivity on the gap sites to which that item is linked. This technology was imported into HPSG as the type-lattice in Levine et al. 2001 to handle case mismatch in parasitic gaps—an application which has no competing treatment via LBE in any HPSG theory of filler/gap connectivity I’m aware of. Given these independently motivated category constructors, the story about (50) is simple: the verb *give* belongs to a set of verbs whose category description in the lexicon is the meet, notated as  $\wedge_m$ , of  $((S \setminus NP)/NP)/NP$  and  $((S \setminus NP)/PP)/NP$ , i.e., simultaneously satisfies both descriptions. Simple proofs utilizing hypothetical reasoning, in conjunction with the theorem in (51)a—which is a strict analogue of ‘strengthening the antecedent’ in propositional logic and provable using completely

<sup>4</sup>A complete proof for (50) was presented at the 2011 Colloque de Syntax et Semantique at Université Paris 8

cognate inference steps—establish as the syntactic description of both *Mary a book* and *a record to Peter* the category label in (51)b:

- (51) a.  $W \setminus Z \vdash (W \wedge_m U) \setminus Z, U \setminus Z \vdash (W \wedge_m U) \setminus Z$   
 b.  $((S \setminus NP)/NP)/NP \wedge_m ((S \setminus NP)/PP)/NP \setminus VP$

and therefore the category of their conjunction. This conjunction, combining with the unitary lexical item *gave*, yields (50) by straightforward left slash elimination, and nothing further need be said. So no special categories, constructions or rules need to be introduced apart from those sanctioned by the completely general inference rules of the natural deduction proof theory that Kubota’s approach shares with the formalisms assumed in the work of Morrill, Bayer, Muskens, Pollard and several other versions of TLCG, along with an independently well-motivated category description (semi)lattice. Seen in the light of the motivated resources of TLGC, Crysmann’s example turns out to be trivially compatible with the framework’s predictions.

### 3 Summary

Notwithstanding its apparently wide acceptance in much recent literature, the use of linearization to resolve a number of persistent empirical challenges to phrase-structure-theoretic approaches faces serious difficulties that have not been confronted. Much of this literature displays cases that represent unproblematic mappings amongst syntactic structure, linear order and meaning; but the range of evidence is remarkably small, and at present far from sufficient to give LBE the status of anything more than an interesting possibility, rather than the default role it seems to have acquired as a way to deal with unlike category and nonconstituent coordination. What the foregoing discussion has shown is that none of the linguistic phenomena represented by the cases listed in (1) are amenable to an LBE treatment once the latter is held accountable for a fuller data range for each of these respective constructions. Given the foregoing, there is no reasonable basis for viewing ellipsis-based accounts within HPSG’s linearization framework as a successful general theory of coordination phenomena.

### References

- Barker, Chris. 2007. Parasitic scope. *Linguistics and Philosophy* 30:407–444.
- Bayer, Samuel. 1996. The coordination of unlike categories. *Language* 72:579–616.
- Beavers, John, and Ivan Sag. 2004. Ellipsis and Apparent Non-Constituent Coordination. In *Proceedings of the 11th International Conference on Head-Driven Phrase Structure Grammar*, ed. Stefan Müller. Stanford: CSLI (<http://cslipublications.stanford.edu/HPSG/5/toc.shtml>).
- Carlson, Gregory. 1987. *Same and different*: Some consequences for syntax and semantics. *Linguistics and Philosophy* 10:531–565.
- Chaves, Rui P., and Ivan Sag. 2009. Left- and right-peripheral ellipsis in coordinate and non-coordinate structures. Stanford/University of Buffalo ms.
- Chaves, Rui Pedro. 2006. Coordination of unlikes without unlike categories. In *Proceedings of the Thirteenth Conference on HPSG*, ed. Stefan Müller. 102–122. Stanford: CSLI (<http://cslipublications.stanford.edu/HPSG/7/chaves.pdf>).

- Chaves, Rui Pedro. 2007. Coordinate Structures: Constraint-Based Syntax-Semantics Processing. Unpublished Ph.D. dissertation, University of Lisbon.
- Copestake, Ann, Dan Flickinger, Ivan Sag, and Carl Pollard. 2006. Minimal Recursion Semantics: an introduction. *Research on Language and Computation* 3:281–332.
- Crysmann, Berthold. 2003. An asymmetric theory of peripheral sharing in HPSG. In *Proceedings of FGVienna: the 8th Conference on Formal Grammar*, ed. Gerald Penn. 45–64. Stanford: Center for the Study of Language and Information (first published in 2003 in the conference proceedings by the European Summer School in Language, Logic and Information (Vienna, Austria)).
- Curry, Haskell. 1963. Some Logical Aspects of Grammatical Structure. In *Structure of Language in its Mathematical Aspects: Proceedings of the Twelfth Symposium in Applied Mathematics*, ed. Roman Jacobson. 56–68. American Mathematical Society.
- Dowty, David. 1985. A unified indexical analysis of *same* and *different*: a response to Stump and Carlson. Paper Presented at University of Texas Workshop on Syntax and Semantics, Austin, Texas, March 2224.
- Heycock, Caroline, and Roberto Zamparelli. 2005. Friends and colleagues: Coordination, plurality, and the structure of DP. *Natural Language Semantics* 13:201–270.
- Keenan, Edward. 1992. Beyond the Frege boundary. *Linguistics and Philosophy* 2:199–2211.
- Levine, Robert, and Thomas Hukari. 2006. *The Unity of Unbounded Dependency Constructions*. Stanford University: Center for the Study of Language and Information.
- Levine, Robert, Thomas E. Hukari, and Michael Calcagno. 2001. Some overlooked parasitic gap constructions in English and their theoretical implications. In *Parasitic Gaps*, ed. Peter Culicover and Paul M. Postal. 181–222. Cambridge: MIT Press.
- Morrill, Glyn. 1994. *Type-logical Grammar: Categor Logic of Signs*. Dordrecht: Kluwer.
- Peterson, Peter. 2004. Coordination: consequences of a Lexical-Functional account. *Natural Language and Linguistic Theory* 22:643–679.
- Reape, Michael. 1993. A Formal Theory of Word Order: a Case Study in West Germanic. Doctoral dissertation, University of Edinburgh.
- Reape, Michael. 1996. Getting Things in Order. In *Discontinuous Constituency*, ed. Arthur Horck and Wuetsje Sijtsma. 209–253. Berlin: Mouton de Gruyter.
- Sabbagh, Joseph. 2007. Ordering and linearizing rightward movement. *Natural Language and Linguistic Theory* 25:349–401.
- Sag, Ivan, Gerald Gazdar, Thomas Wasow, and Steven Weisler. 1985. Coordination and how to distinguish categories. *Natural Language and Linguistic Theory* 3:117–171.