

Perception

Maneesh Agrawala

CS 448B: Visualization
Spring 2016

**Last Time:
Multidimensional Visualization**

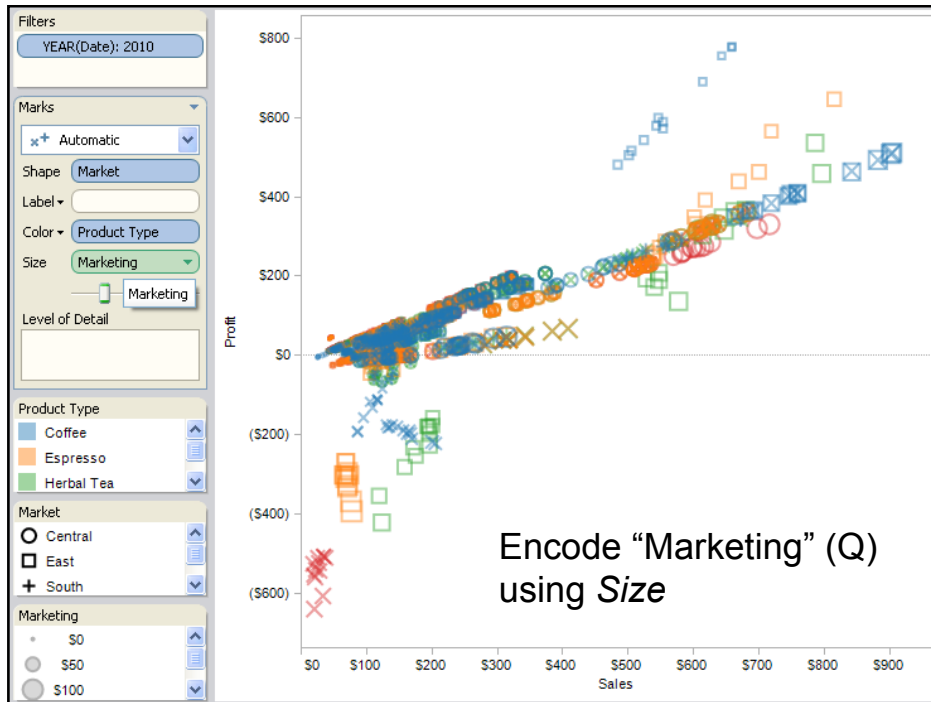

Visualizing Multiple Dimensions

Strategies

- Avoid "over-encoding"
- Use space and small multiples intelligently
- Reduce the problem space
- Use interaction to generate *relevant* views

There is rarely a single visualization that answers all questions. Instead, the ability to generate appropriate visualizations quickly is key

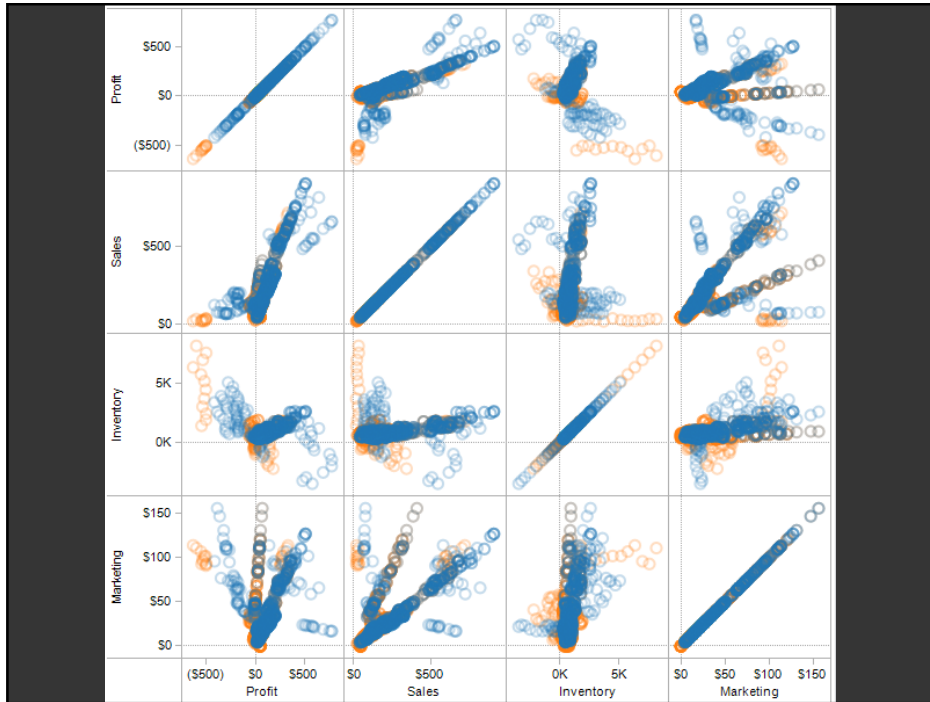

Parallel Coordinates [Inselberg]

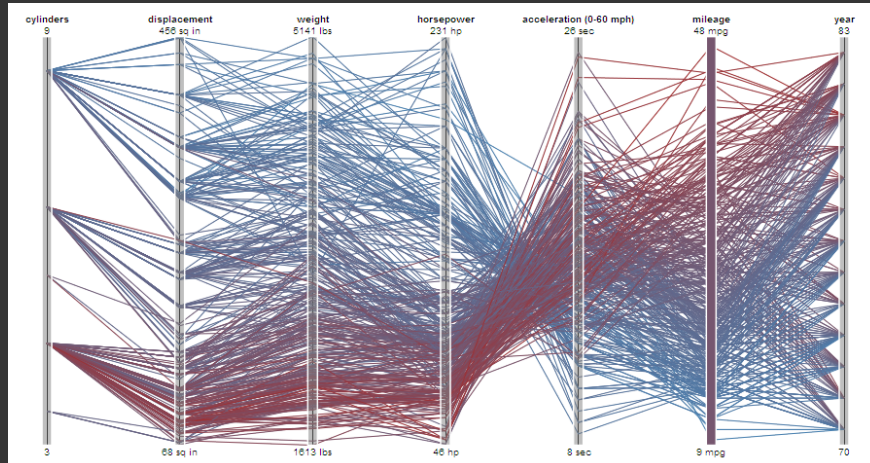

<http://mbostock.github.io/protovis/ex/cars.html>

Tableau

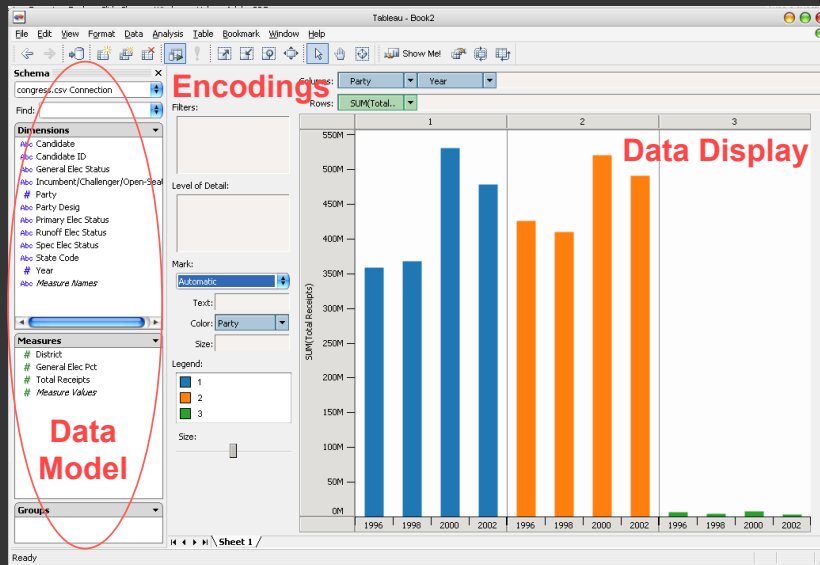

Specifying Table Configurations

Operands are names of database fields

Each operand interpreted as a set {...}

Quantitative and Ordinal fields treated differently

Three operators:

concatenation (+)

cross product (x)

nest (/)

Announcements

Assignment 2: Exploratory Data Analysis

Use **Tableau** to formulate & answer questions

First steps

- Step 1: Pick a domain
- Step 2: Pose questions
- Step 3: Find data
- Iterate

Create visualizations

- Interact with data
- Question will evolve
- Tableau

Make wiki notebook

- Keep record of all steps you took to answer the questions

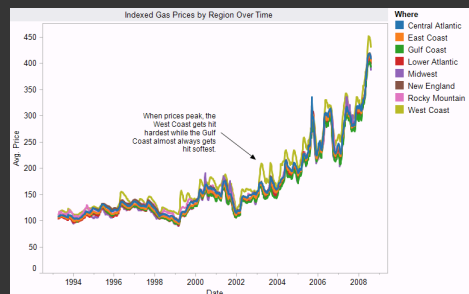

Due before class on Apr 18, 2016

Perception

Mackinlay's ranking of encodings

QUANTITATIVE	ORDINAL	NOMINAL
Position	Position	Position
Length	Density (Val)	Color Hue
Angle	Color Sat	Texture
Slope	Color Hue	Connection
Area (Size)	Texture	Containment
Volume	Connection	Density (Val)
Density (Val)	Containment	Color Sat
Color Sat	Length	Shape
Color Hue	Angle	Length
Texture	Slope	Angle
Connection	Area (Size)	Slope
Containment	Volume	Area
Shape	Shape	Volume

Topics

Signal Detection

Magnitude Estimation

Pre-Attentive Visual Processing

Using Multiple Visual Encodings

Gestalt Grouping

Change Blindness

Detection

Detecting brightness

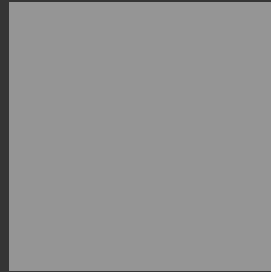
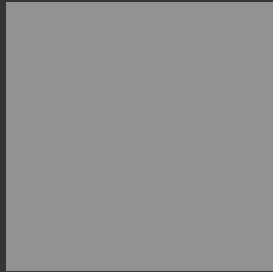

Which is brighter?

Detecting brightness

(128, 128, 128)



(130, 130, 130)



Which is brighter?

Just noticeable difference

JND (Weber's Law)

$$\Delta S = k \frac{\Delta I}{I}$$

- Ratios more important than magnitude
- Most continuous variations in stimuli are perceived in discrete steps



Information in color and value

Value is perceived as ordered

∴ Encode ordinal variables (O)



∴ Encode continuous variables (Q) [not as well]

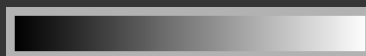

Hue is normally perceived as unordered

∴ Encode nominal variables (N) using color



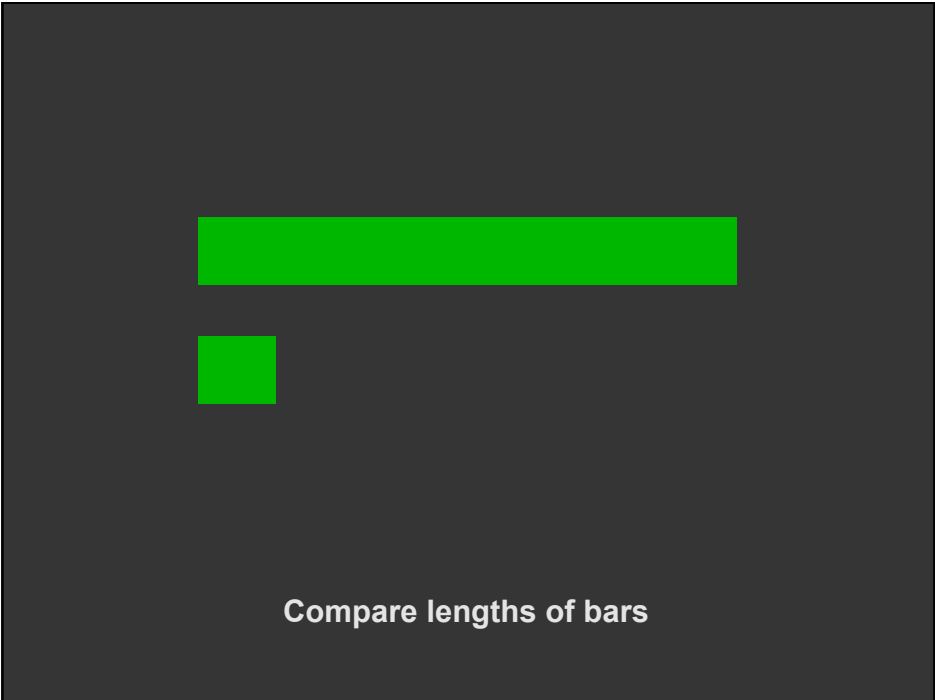
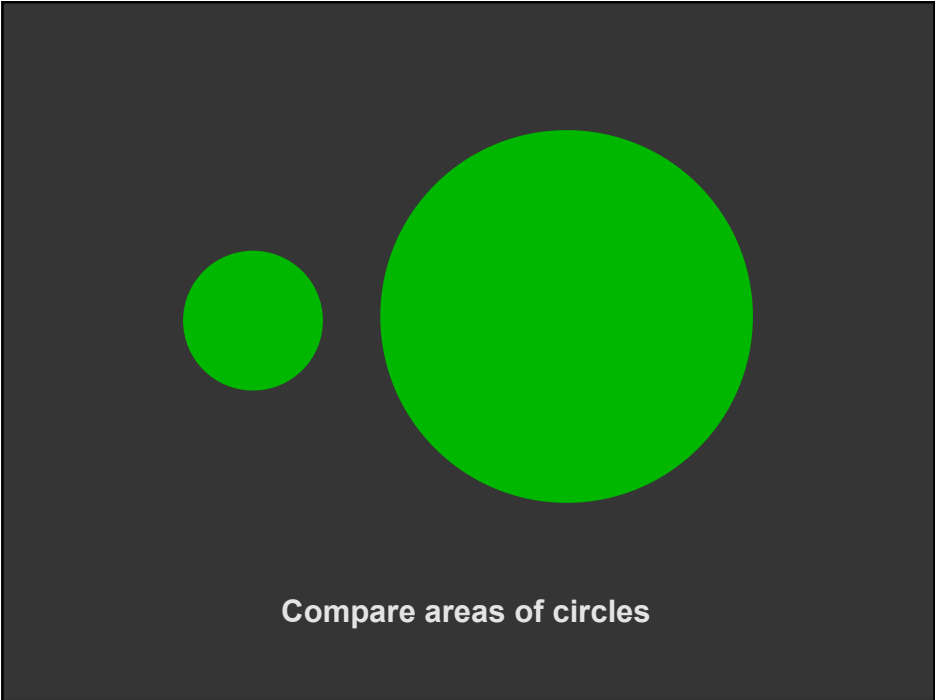

Steven's power law

$$S = I^p$$

$p < 1$: underestimate
 $p > 1$: overestimate

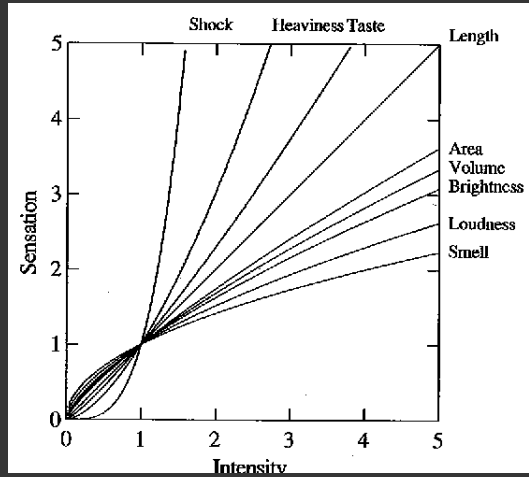

[graph from Wilkinson 99, based on Stevens 61]

Exponents of power law

Sensation	Exponent
Loudness	0.6
Brightness	0.33
Smell	0.55 (Coffee) - 0.6 (Heptane)
Taste	0.6 (Saccharine) -1.3 (Salt)
Temperature	1.0 (Cold) – 1.6 (Warm)
Vibration	0.6 (250 Hz) – 0.95 (60 Hz)
Duration	1.1
Pressure	1.1
Heaviness	1.45
Electric Shock	3.5

[Psychophysics of Sensory Function, Stevens 61]

Apparent magnitude scaling

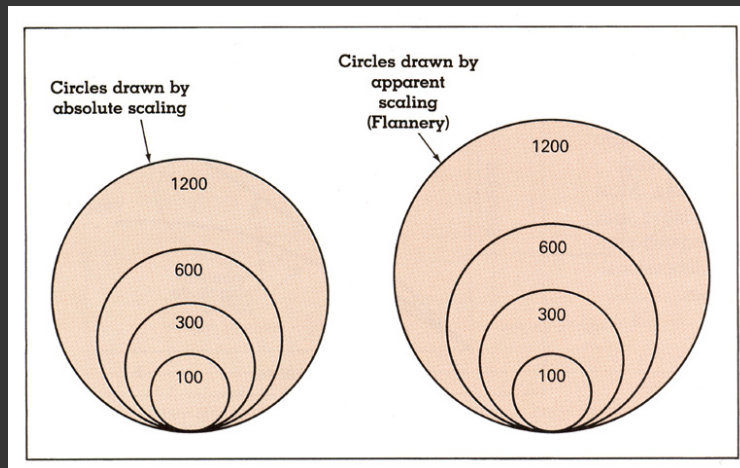

[Cartography: Thematic Map Design, Figure 8.6, p. 170, Dent, 96]

$$S = 0.98A^{0.87} \text{ [from Flannery 71]}$$

Proportional symbol map

Newspaper Circulation

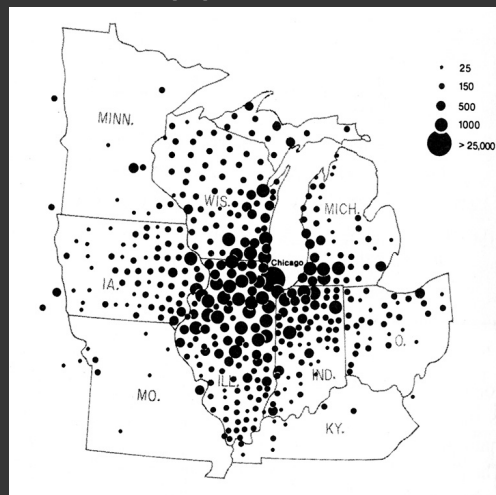

[Cartography: Thematic Map Design, Figure 8.8, p. 172, Dent, 96]

Graduated sphere map

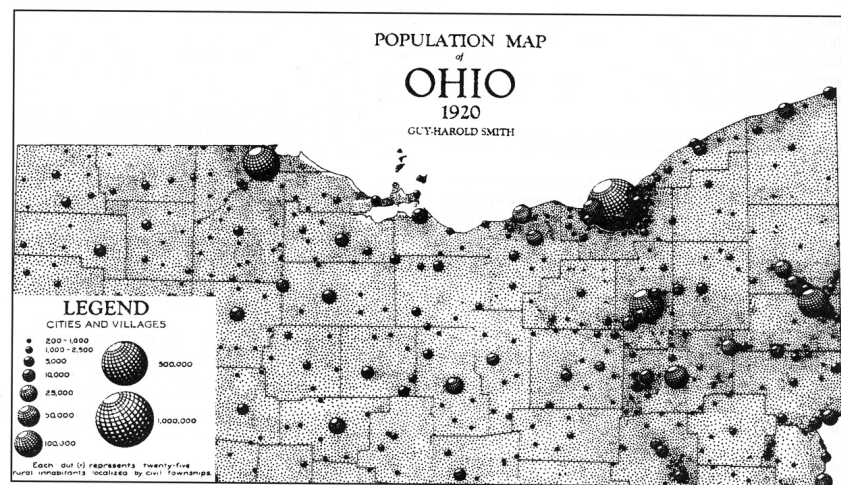
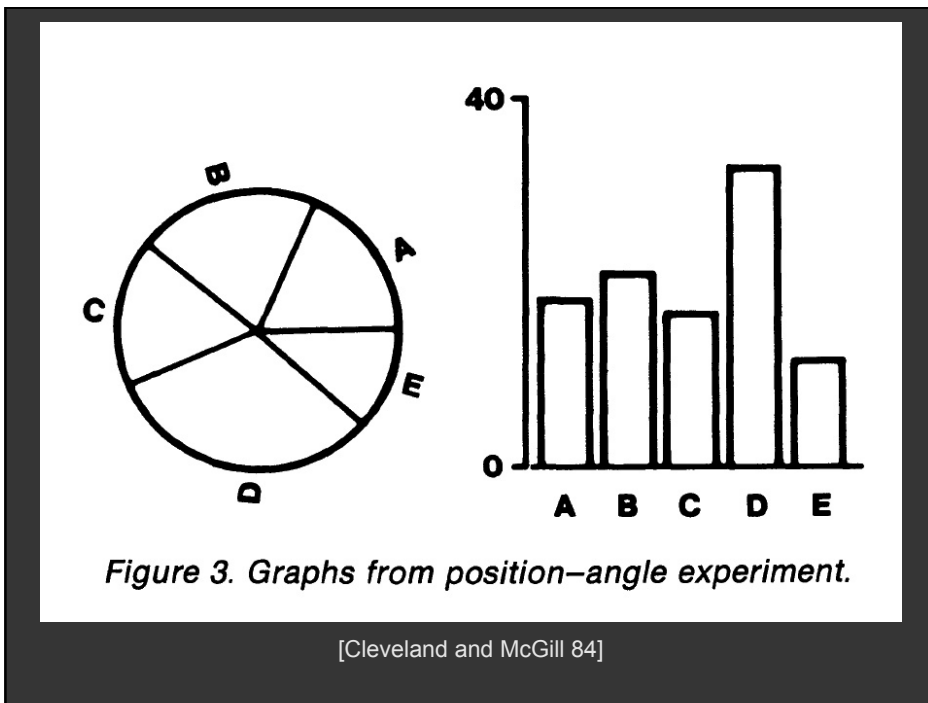
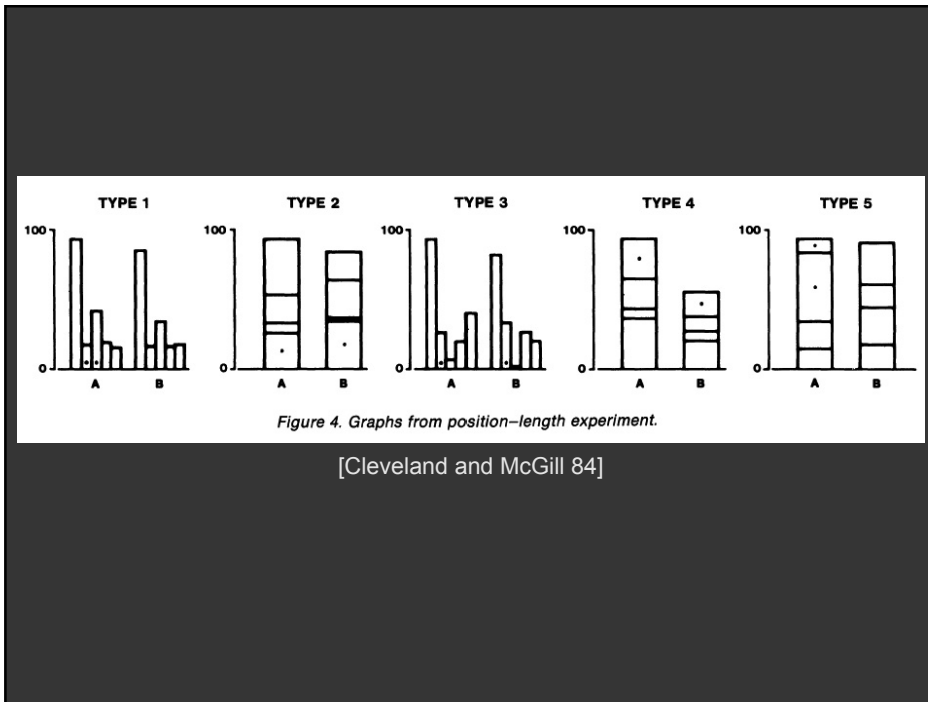
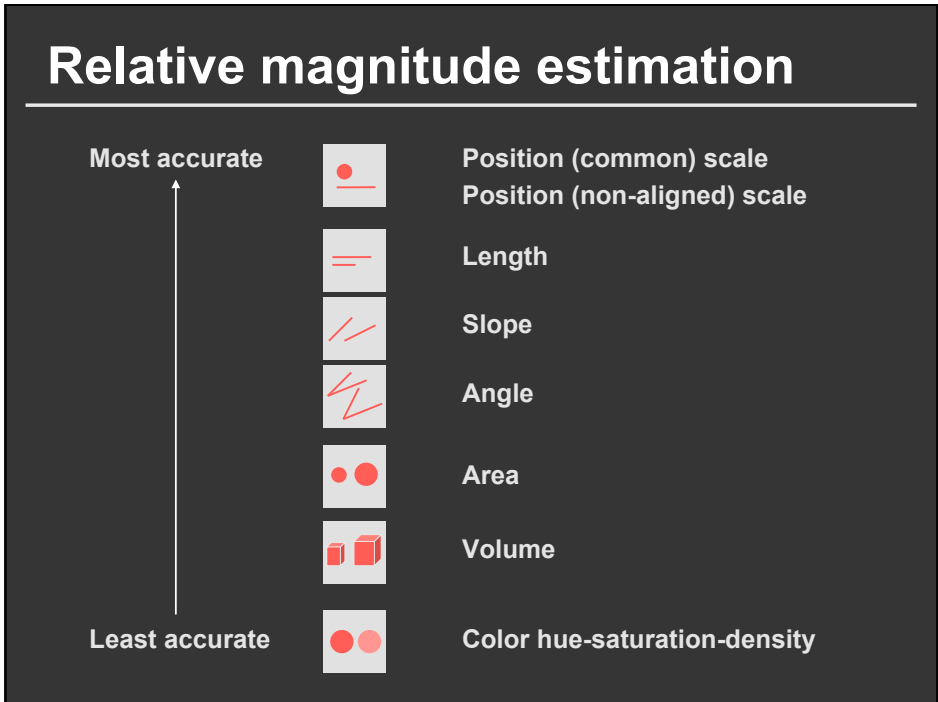
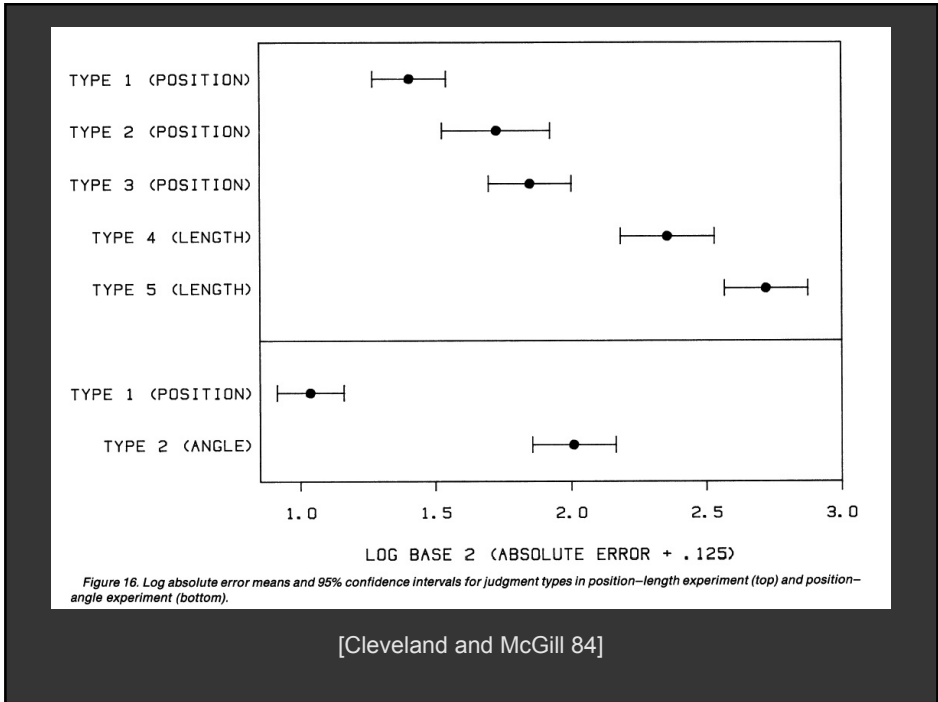

FIGURE 7.4. An eye-catching map created using three-dimensional geometric symbols. (After Smith, 1928. First published in *The Geographical Review*, 18(3), plate 4. Reprinted with permission of the American Geographical Society.)

Cleveland and McGill





Mackinlay's ranking of encodings

QUANTITATIVE	ORDINAL	NOMINAL
Position	Position	Position
Length	Density (Val)	Color Hue
Angle	Color Sat	Texture
Slope	Color Hue	Connection
Area (Size)	Texture	Containment
Volume	Connection	Density (Val)
Density (Val)	Containment	Color Sat
Color Sat	Length	Shape
Color Hue	Angle	Length
Texture	Slope	Angle
Connection	Area (Size)	Slope
Containment	Volume	Area
Shape	Shape	Volume

Conjectured *effectiveness* of visual encodings

Preattentive vs. Attentive

How many 3's

1281768756138976546984506985604982826762
9809858458224509856458945098450980943585
9091030209905959595772564675050678904567
8845789809821677654876364908560912949686

[based on slide from Stasko]

How many 3's

12817687561**3**8976546984506985604982826762
980985845822450985645894509845098094**3**585
90910**3**0209905959595772564675050678904567
8845789809821677654876**3**64908560912949686

[based on slide from Stasko]

Visual pop-out: Color

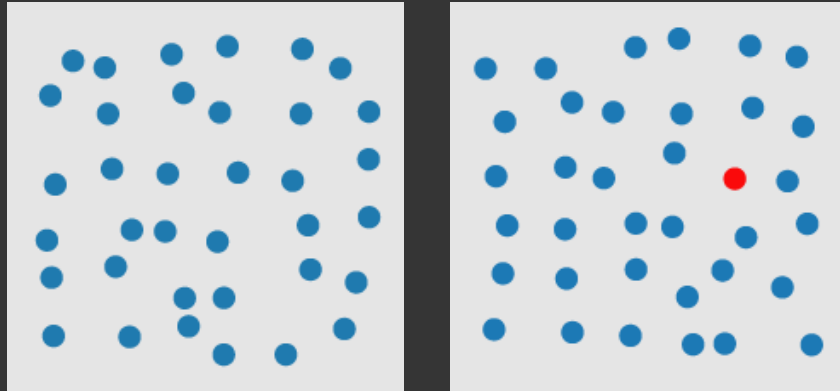

<http://www.csc.ncsu.edu/faculty/healey/PP/index.html>

Visual pop-out: Shape

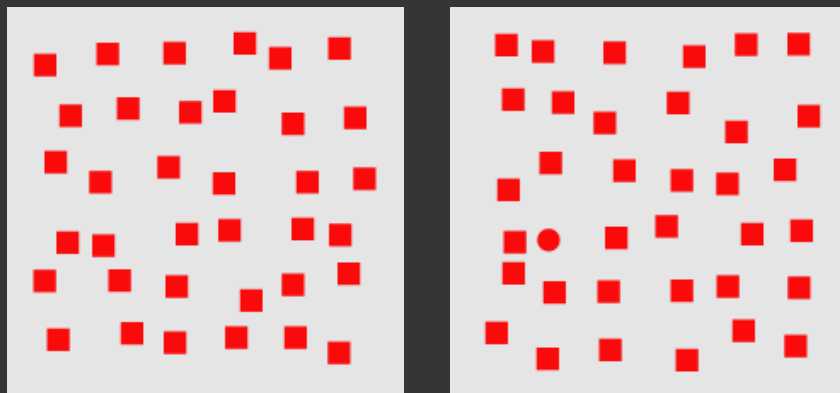

<http://www.csc.ncsu.edu/faculty/healey/PP/index.html>

Feature conjunctions

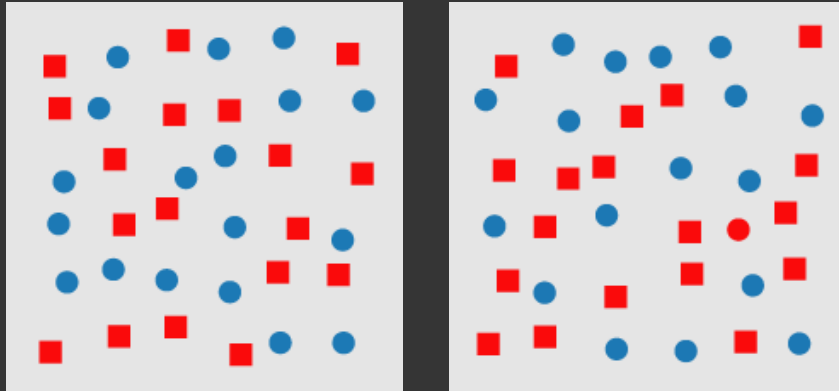

<http://www.csc.ncsu.edu/faculty/healey/PP/index.html>

Preattentive features

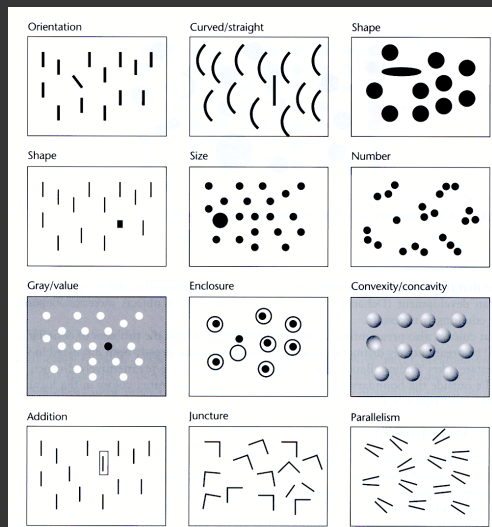

[Information Visualization. Figure 5. 5 Ware 04]

More preattentive features

Line (blob) orientation	Julesz & Bergen [1983]; Wolfe et al. [1992]
Length	Triesman & Gormican [1988]
Width	Julesz [1985]
Size	Triesman & Gelade [1980]
Curvature	Triesman & Gormican [1988]
Number	Julesz [1985]; Trick & Pylyshyn [1994]
Terminators	Julesz & Bergen [1983]
Intersection	Julesz & Bergen [1983]
Closure	Enns [1986]; Triesman & Souther [1985]
Colour (hue)	Nagy & Sanchez [1990, 1992]; D'Zmura [1991]; Kawai et al. [1995]; Bauer et al. [1996]
Intensity	Beck et al. [1983]; Triesman & Gormican [1988]
Flicker	Julesz [1971]
Direction of motion	Nakayama & Silverman [1986]; Driver & McLeod [1992]
Binocular lustre	Wolfe & Franzel [1988]
Stereoscopic depth	Nakayama & Silverman [1986]
3-D depth cues	Enns [1990]
Lighting direction	Enns [1990]

<http://www.csc.ncsu.edu/faculty/healey/PP/index.html>

Preattentive conjunctions

Spatial conjunctions are often preattentive

- Motion and 3D disparity
- Motion and color
- Motion and shape
- 3D disparity and color
- 3D disparity and shape

Most conjunctions are **not** preattentive

Feature-integration theory

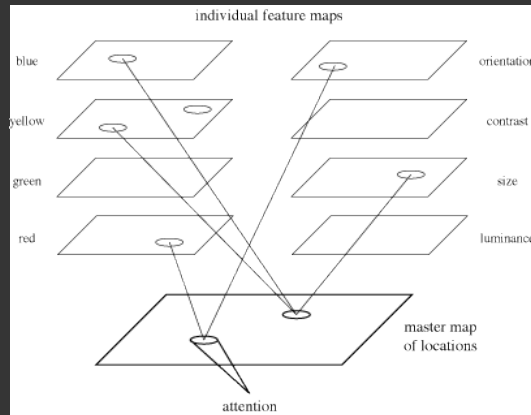

Treisman's feature integration model [Healey04]

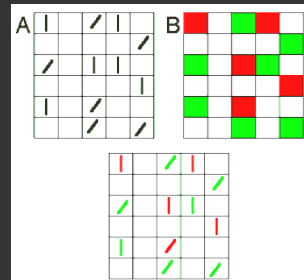

Feature maps for orientation & color [Green]

Multiple Attributes

One-dimensional: Lightness

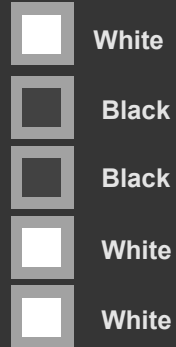
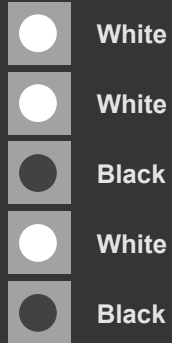

One-dimensional: Shape

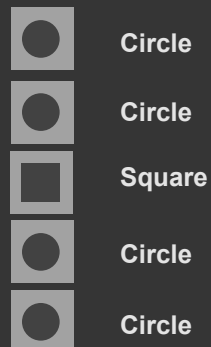
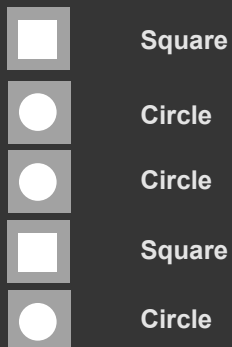

Correlated dims: Shape or lightness



	Circle
	Square
	Square
	Circle
	Square

	Circle
	Square
	Square
	Square
	Circle

Orthogonal dims: Shape & lightness



	Circle
	Square
	Square
	Circle
	Square

Speeded classification

Redundancy gain

Facilitation in reading one dimension when the other provides redundant information

Filtering interference

Difficulty in ignoring one dimension while attending to the other

Speeded classification

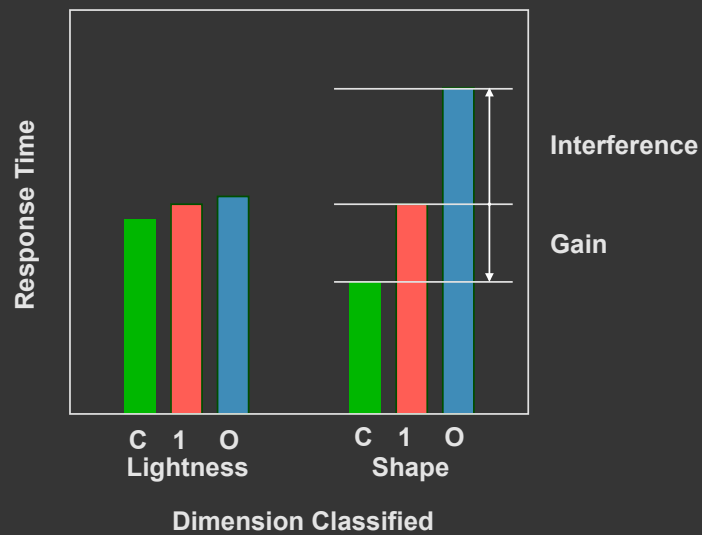

Types of dimensions

Integral

Filtering interference and redundancy gain

Separable

No interference or gain

Configural

Only interference, but no redundancy gain

Asymmetrical

One dimension separable from other, not vice versa

Stroop effect – Color naming influenced by word identity, but word naming not influenced by color

Correlated dims: Size and value

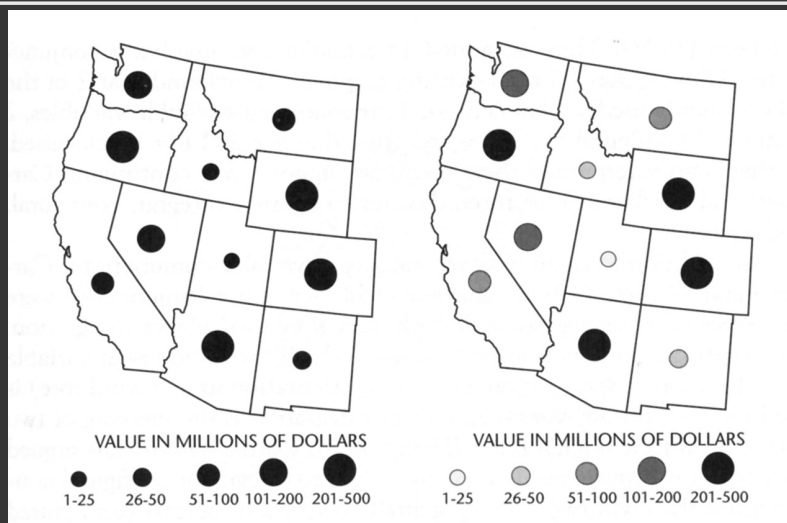

W. S. Dobson, Visual information processing and cartographic communication: The role of redundant stimulus dimensions, 1983 (reprinted in MacEachren, 1995)

Othogonal dims: Aspect ratio

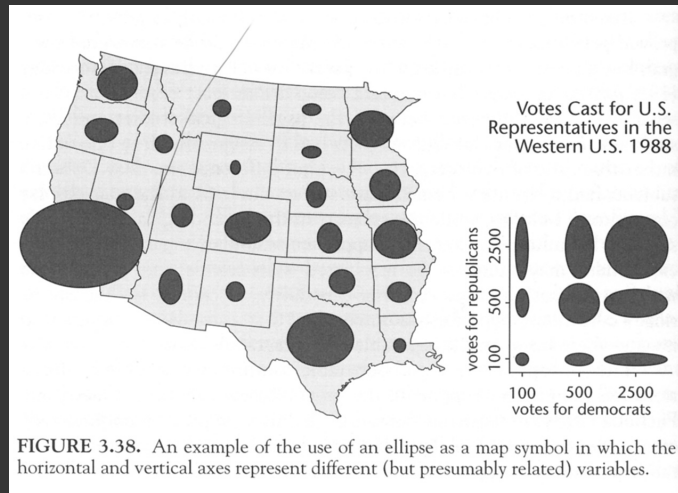

[MacEachren 95]

Orientation and Size (Single Mark)

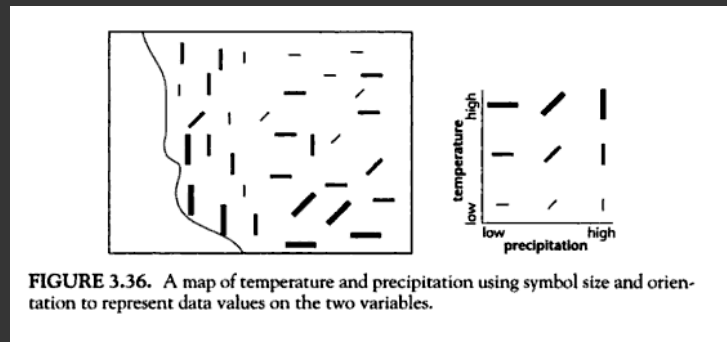

How well can you see temperature or precipitation?
Is there a correlation between the two?

[MacEachren 95]

Shape and Size (Single Mark)

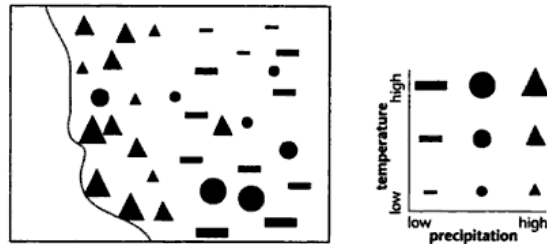
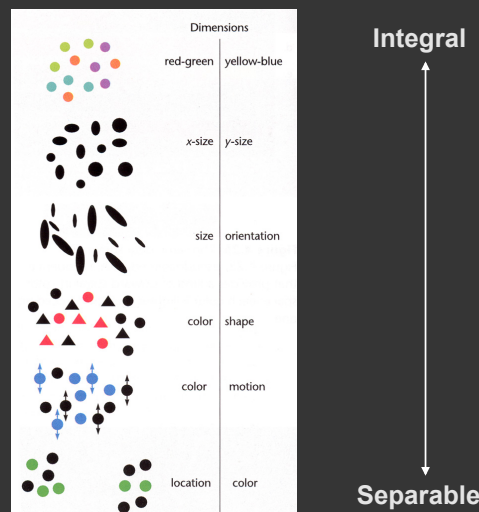

FIGURE 3.40. The bivariate temperature-precipitation map of Figure 3.36, this time using point symbols that vary in shape and size to represent the two quantities.

Easier to see one shape across multiple sizes than one size of across multiple shapes?

[MacEachren 95]

Summary of Integral-Separable



[Figure 5.25, Color Plate 10, Ware 00]

Gestalt

Principles

- figure/ground
- proximity
- similarity
- symmetry
- connectedness
- continuity
- closure
- common fate
- transparency

Figure/Ground



Ambiguous

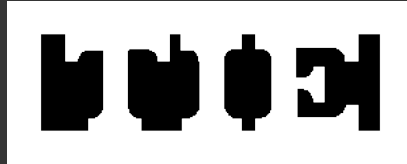

Principle of surroundedness

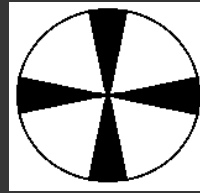

Principle of relative size

<http://www.aber.ac.uk/media/Modules/MC10220/visper06.html>

Figure/Ground



Ambiguous



Unambiguous

<http://www.aber.ac.uk/media/Modules/MC10220/visper06.html>

Proximity

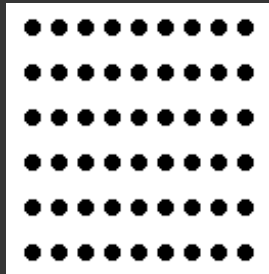
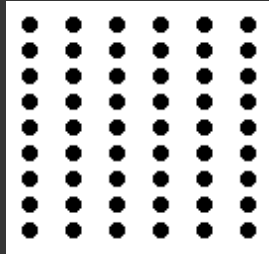

[Ware 00]

Similarity

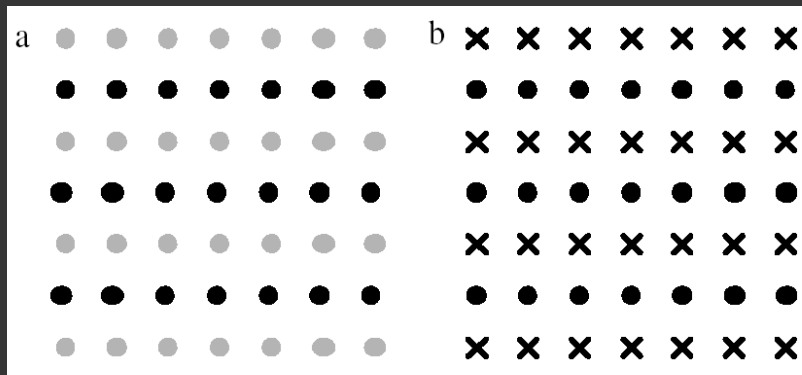

Rows dominate due to similarity [from Ware 04]

Symmetry

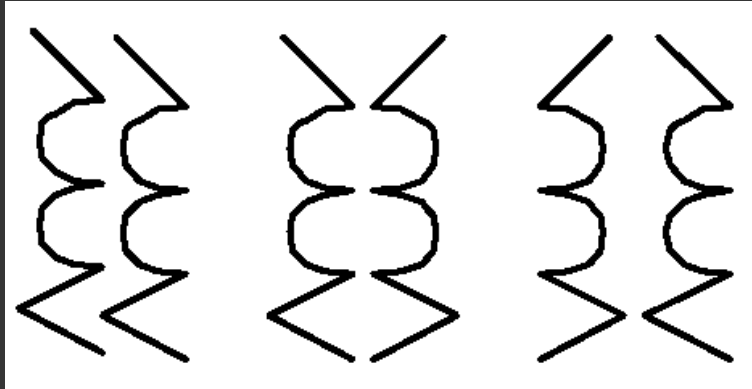

Bilateral symmetry gives strong sense of figure [from Ware 04]

Connectedness

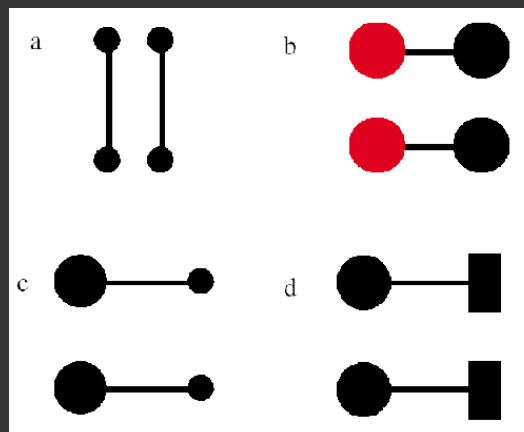

Connectedness overrules proximity, size, color shape [from Ware 04]

Continuity

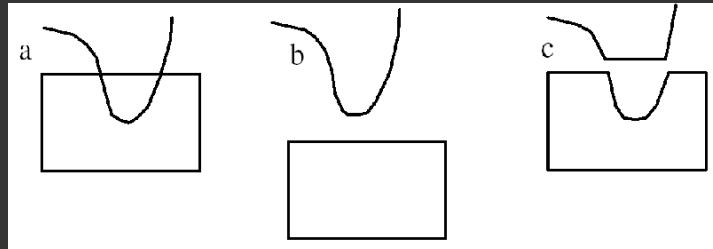

We prefer smooth not abrupt changes [from Ware 04]

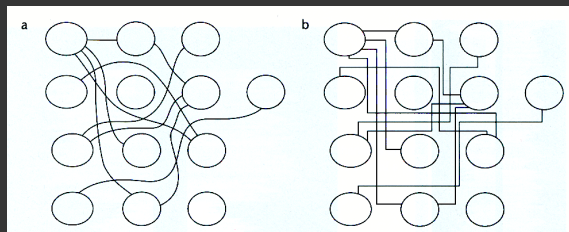

Connections are clearer with smooth contours [from Ware 04]

Continuity: Vector fields

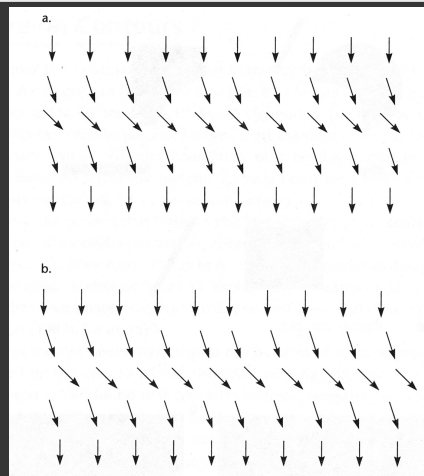

Prefer field that shows smooth continuous contours [from Ware 04]

Closure

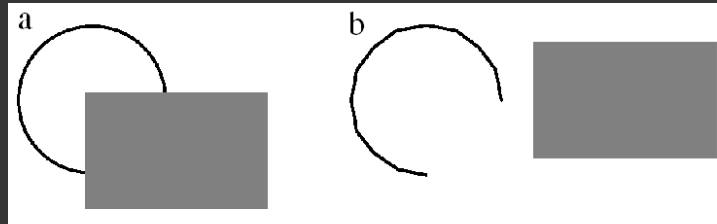

We see a circle behind a rectangle, not a broken circle [from Ware 04]

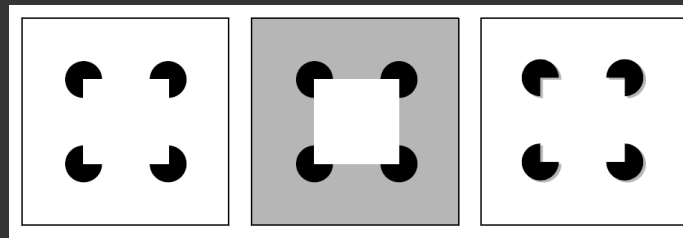

Illusory contours [from Durand 02]

Common fate

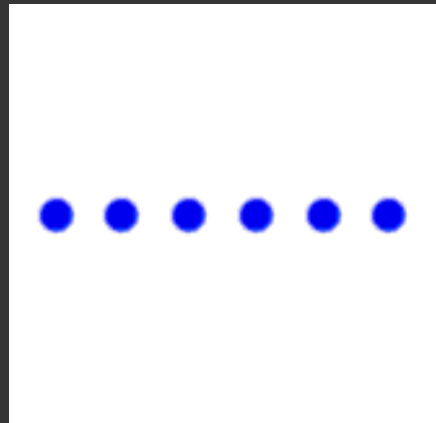

Dots moving together are grouped

<http://coe.sdsu.edu/eet/articles/visualperc1/start.htm>

Transparency



Requires continuity and proper color correspondence [from Ware 04]

Layering and Small Multiples

Layering: Gridlines

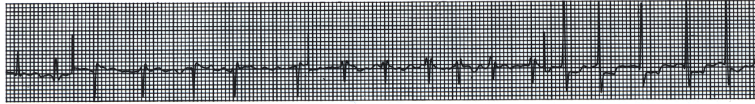

Signal and background compete above, as an electrocardiogram trace-line becomes caught up in a thick grid. Below, the screened-down grid stays behind traces from each of 12 monitoring leads:⁴

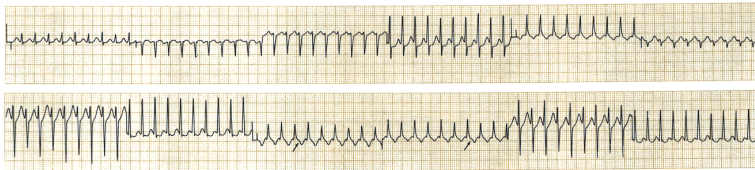

Electrocardiogram tracelines [from Tufte 90]

Layering: Gridlines

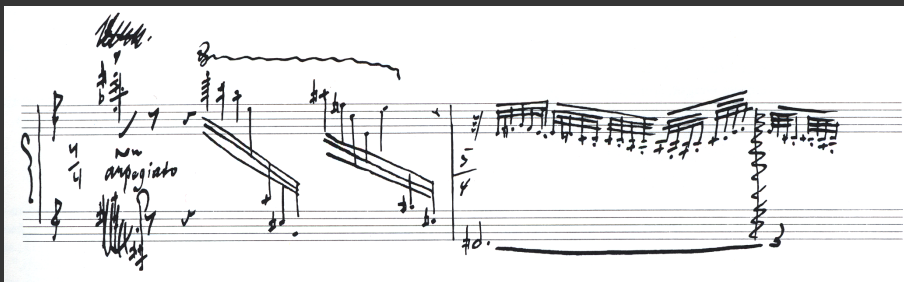

Stravinsky score [from Tufte 90]

Setting Gridline Contrast

How light can gridlines be and remain visible?
How dark can gridlines be and not distract?

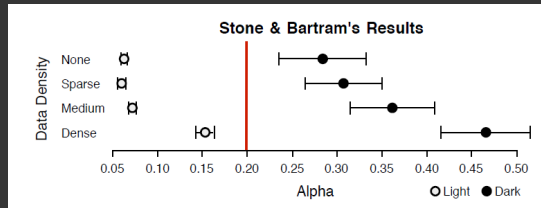

Safe setting:
20% Alpha

[Stone & Bartram 2009]

Layering: Color and line width

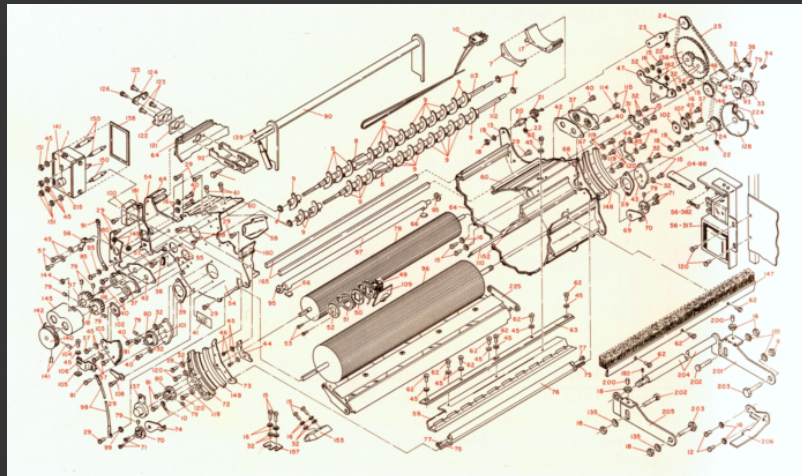

IBM Series III Copier [from Tufte 90]

Small multiples

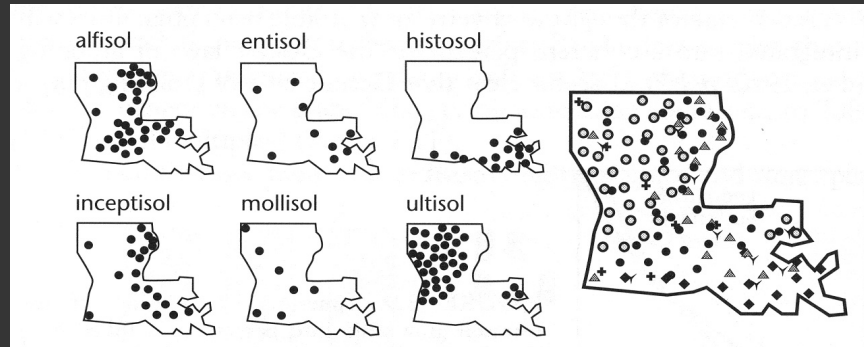

[Figure 2.11, p. 38, MacEachren 95]

Small multiples

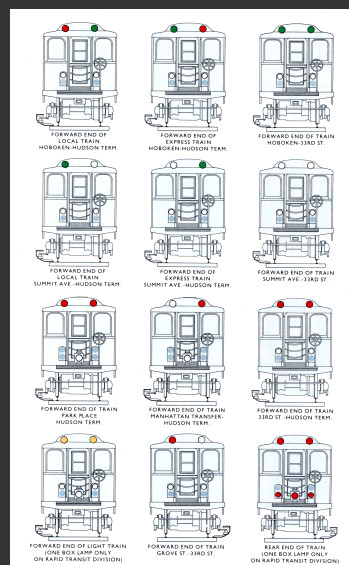

Operating trains. Redrawn by Tufte to emphasize colored lights. [from Tufte 90]

Change blindness

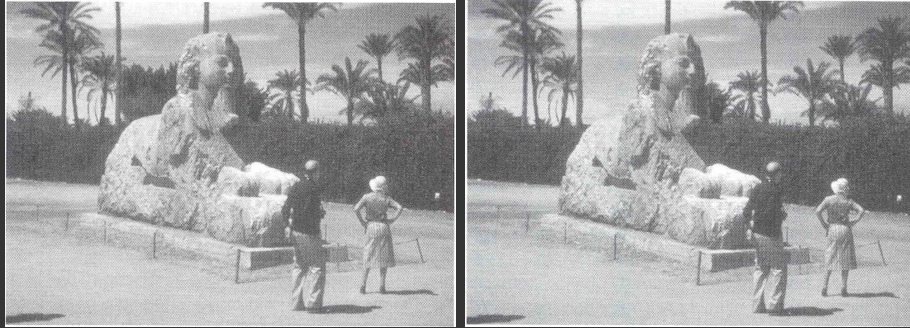

[Example from Palmer 99, originally due to Rock]

Change detection



Change detection



Rensink's demonstration



<http://www.csc.ncsu.edu/faculty/healey/PP/index.html>

Summary

Choosing effective visual encodings requires knowledge of visual perception

Visual features/attributes

- Individual attributes often preattentive
- Multiple attributes may be separable, often integral

Gestalt principles provide higher level design guidelines

We don't always see everything that is there