

E40M

KCL, KVL & Energy Flow

Understanding the Solar Charger – Lab Project #1

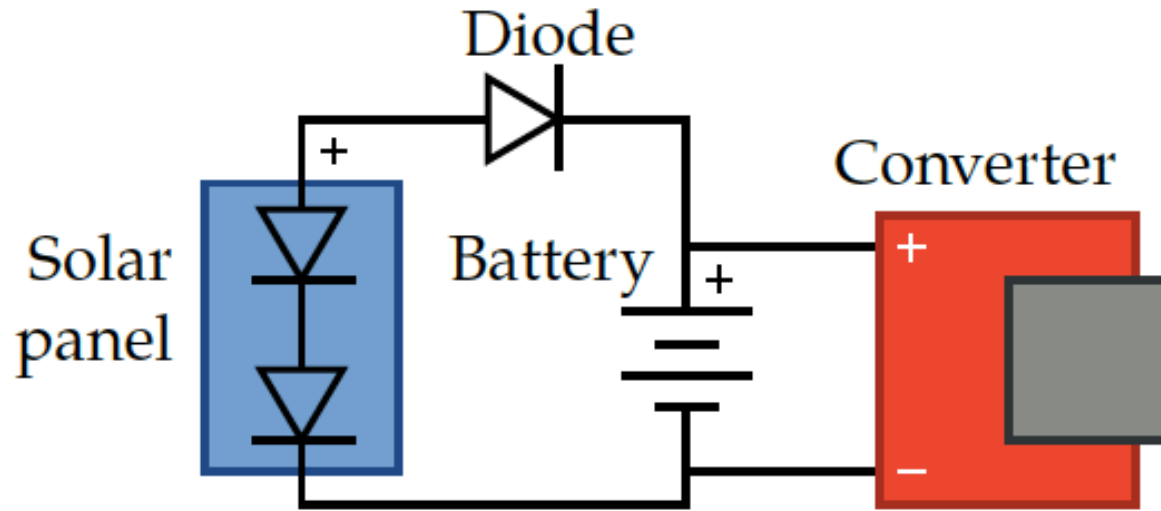

We need to understand how:

1. Current, voltage and power behave in circuits
2. Electrical devices constrain current and voltage
3. Diodes including solar cells work
4. Voltage converter works (later in the quarter).

Key Ideas on Charge, Current, Voltage and Electrical Circuits - Review

- Understand that **charge** is what makes components electrical
 - Moving charge is called **current**, and often represented by “**i**”
 - Measured in **Amps** = Coulombs/sec
- Understand that all components and wires are **charge neutral**
 - This means that the net charge flowing into an object is 0
 - KCL – The sum of the currents into an device or wire = 0
- The force that causes the charge to move is called **Voltage**
 - Measured in **Volts** = Joules/Coulomb
 - Voltage is a potential energy difference
 - Measured between two nodes

Key Ideas on Charge, Current, Voltage and Electrical Circuits - Review

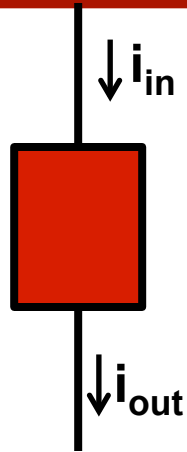

An electrical device is an object that charge (electrons) can move through, so current can flow through it. Devices are neutral (zero charge), so that

$$i_{in} = i_{out}$$

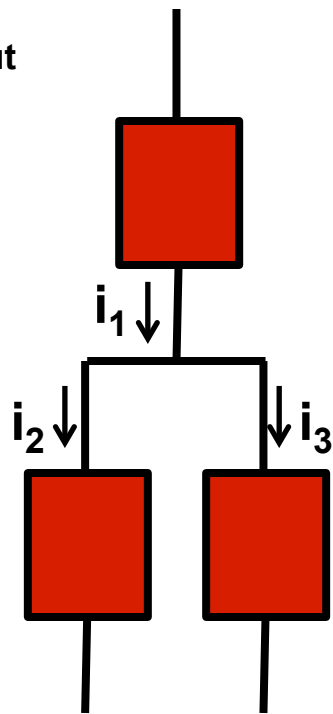

More generally, Kirchhoff's Current Law (KCL) states that the current flowing out of any node must equal the current flowing in. So, for example,

$$i_1 = i_2 + i_3$$

Key Ideas on Charge, Current, Voltage and Electrical Circuits - Review

Charge can be separated in an electrical device if we provide the energy to “pull” the charges apart. Batteries use chemical reactions to separate the charges. Volts (Joules/Coulomb) are the units of potential energy.

If an electrical device is connected to a battery or voltage source, current measured in amperes (amps) will flow through the device.

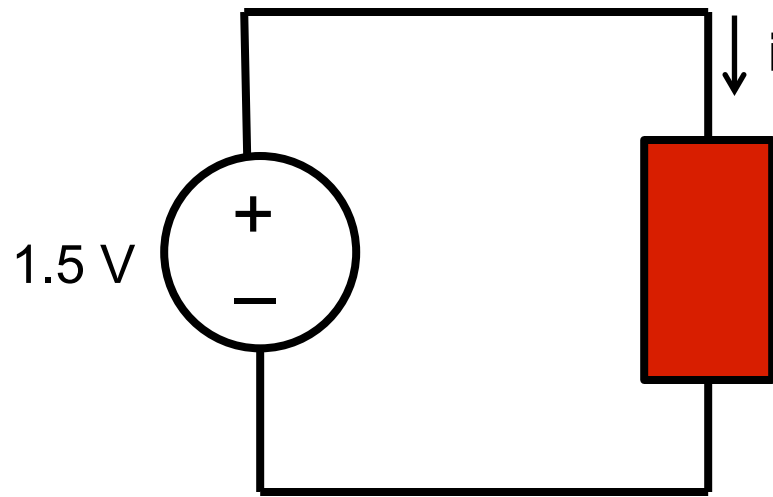

Reading on KCL, KVL and Energy Flow

- Chapter 1 in the course reader

OR

- A&L 1.6-1.7 - Two terminal elements
 - Voltage source; resistor; wires
- A&L 2.1-2.2 – Circuit Laws KCL & KVL

Standard Prefixes for SI Units

Factor	Prefix	Symbol
1,000,000,000 = 10^9	giga	G
1,000,000 = 10^6	mega	M
1,000 = 10^3	kilo	k
100 = 10^2	hecto	h
10 = 10^1	deka	da
0.1 = 10^{-1}	deci	d
0.01 = 10^{-2}	centi	c
0.001 = 10^{-3}	milli	m
0.000001 = 10^{-6}	micro	μ
0.000000001 = 10^{-9}	nano	n
0.000000000001 = 10^{-12}	pico	p

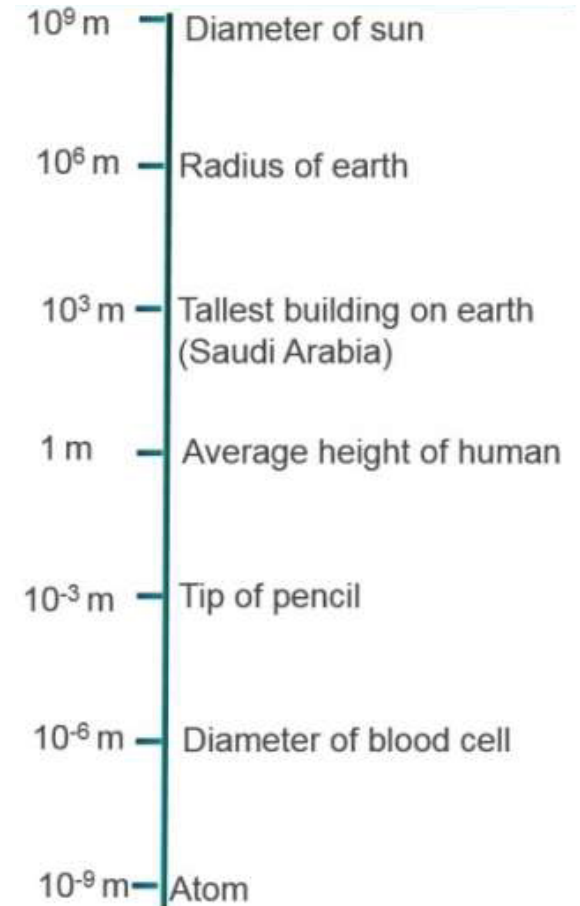

Example, if the unit is a meter

Kirchhoff's Current and Voltage Laws (KCL & KVL)

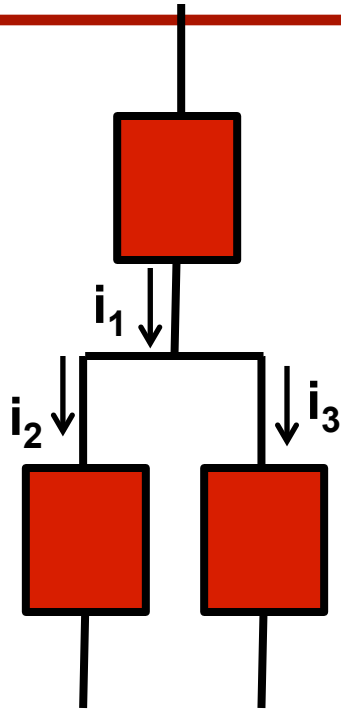

Kirchhoff's Current Law (KCL) states that the current flowing out of any node must equal the current flowing in. So, for example,

$$i_1 = i_2 + i_3$$

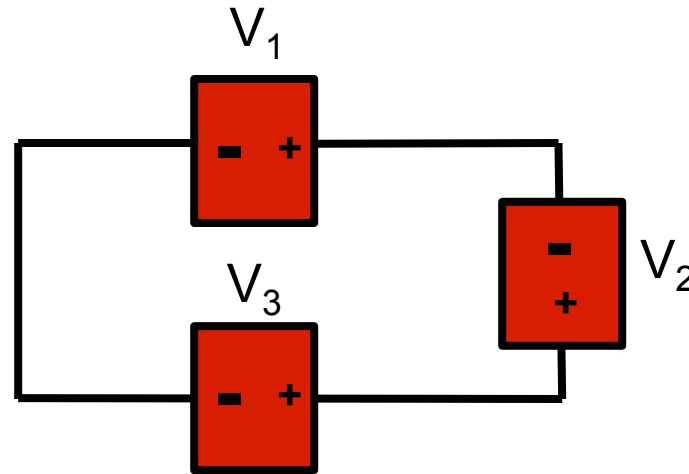

Kirchhoff's Voltage Law (KVL) states that the algebraic sum of the voltages around any closed path must be zero. So, for example,

$$V_1 + V_2 - V_3 = 0$$

Please Note: What the '+' and '-' next to a Device and What an '→' Next to a Wire Mean

- Notice that when we measure a voltage across a device
 - We add a “+” to one lead and “-” to the other
 - These define the reference direction for the voltage measurement
- **It does *NOT* mean that the “+” lead is higher than the “-” lead**
- It means that:
 - You should connect the **red** lead of your DMM to the “+” terminal
 - You should connect the **black** lead to the “-” terminal
 - The voltage you measure could be positive or negative
- Similarly an → is only an ***assumed*** current direction. The measured or calculated current can be positive or negative.

Reference Conventions

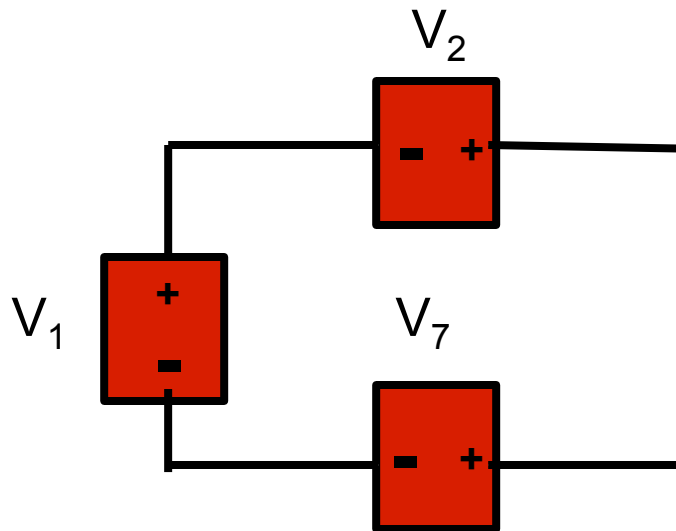

$$V_1 + V_2 - V_7 = 0$$

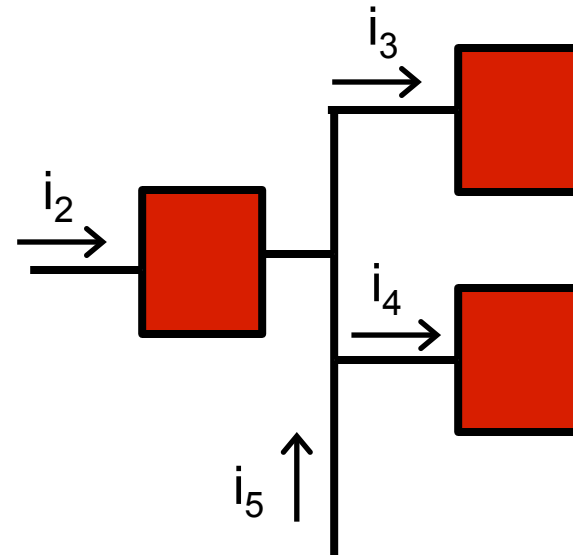

$$i_2 + i_5 = i_3 + i_4$$

When we do real problems like this we may calculate positive or negative answers for the various voltages and currents. It doesn't matter what assumptions you make in doing your analysis.

Example #1: Kirchhoff's Voltage Law (KVL)

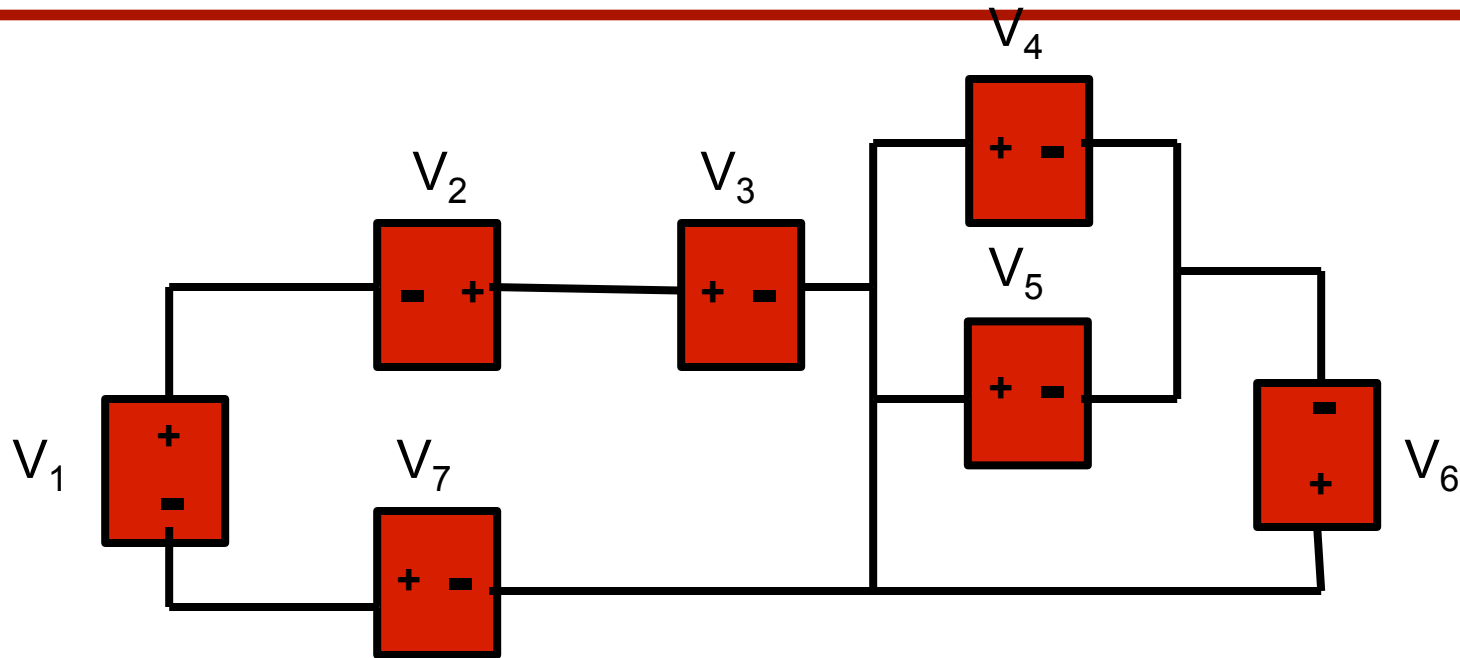

$$V_1 + V_2 - V_3 - V_4 + V_6 + V_7 = 0$$

$$V_1 + V_2 - V_3 + V_7 = 0$$

$$\therefore -V_4 + V_6 = 0 \quad (\text{Check for consistency})$$

Quiz: What can you say about V_4 and V_5 ?

Example #2: Kirchhoff's Current Law (KCL)

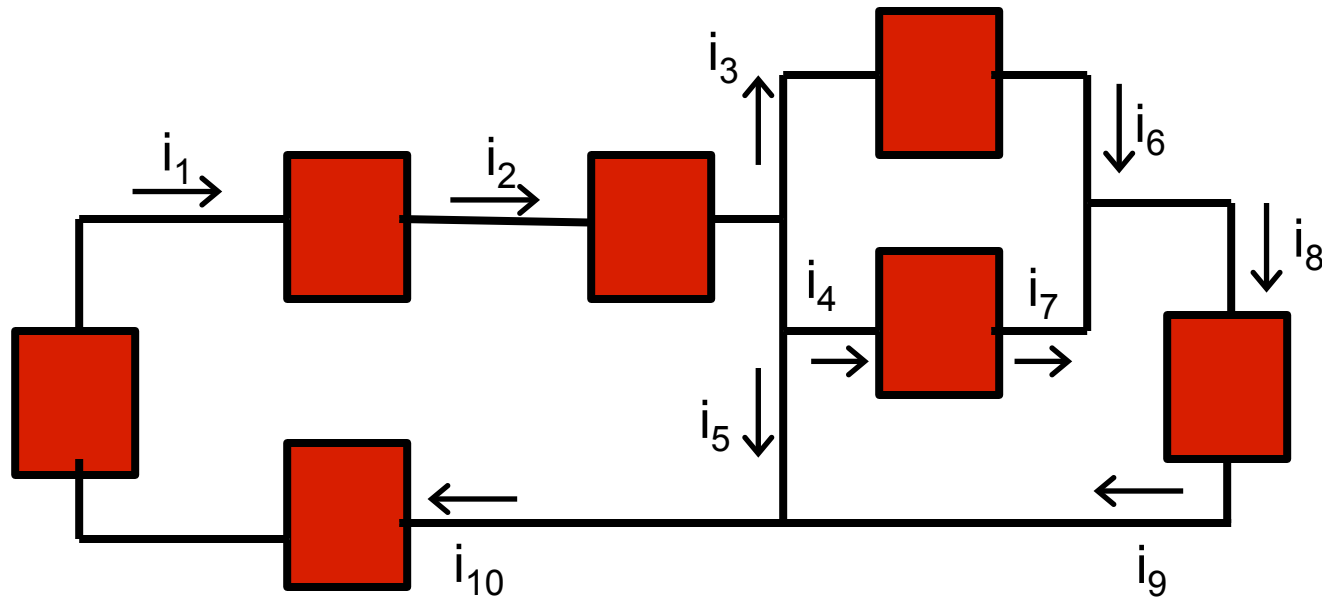

$$i_1 = i_2 = i_{10}$$

$$i_2 = i_3 + i_4 + i_5$$

$$i_3 = i_6 \text{ and } i_4 = i_7$$

$$i_8 = i_9 = i_{10} - i_5$$

Using KCL and KVL

- Find the current, and voltages for the circuit below

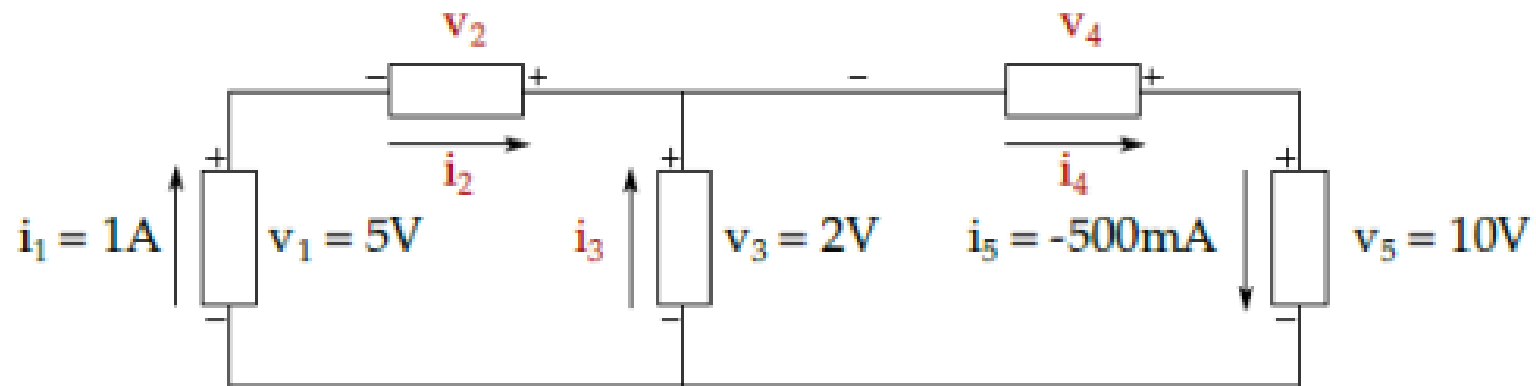

Getting Back to the Solar Charger: Energy and Power

- Look inside:
 - See a number of different devices wired together in a circuit:

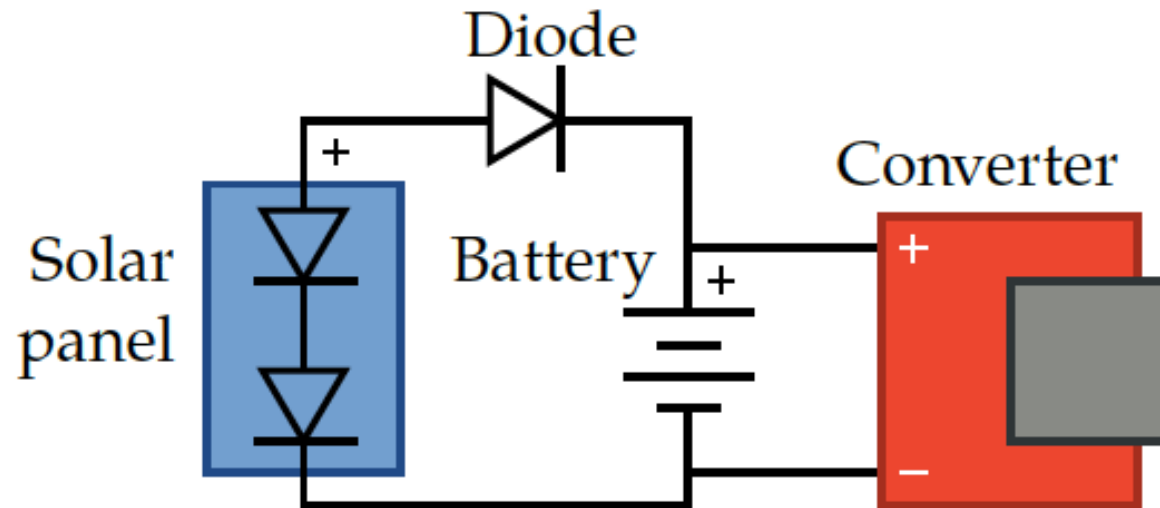

- Need to move energy around
 - And that is done with voltage and current

Electrical Power and Energy

- Voltage is electrical potential energy
 - Volt = Joule/Coulomb
 - Means moving 1 Coulomb of charge up 1V requires 1J
- Remember definition of an amp?
 - Coulomb/sec
- Power “consumed/provided” in the electrical component
 - $(i) \cdot (V) = 1A \cdot 1V = 1 \text{ Joule/sec} = 1 \text{ Watt of energy}$
 - Often the lost energy is converted to heat
- Power is the rate of energy transfer i.e. $\text{Power} = \text{Energy/sec}$
or $\text{Energy transferred} = (\text{Power})(\text{time})$

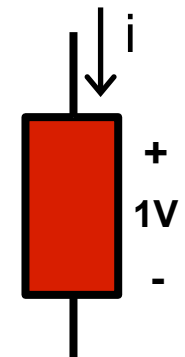
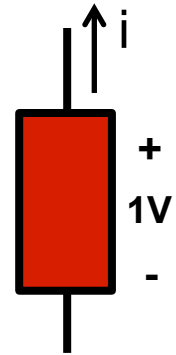

Getting a Feeling for a Watt

- Quick physics review
 - Unit of energy Joule = Coulomb · Volt
 - Unit of power Watt = Joule/sec = A·V
- If those mean nothing to you
 - You probably know about calories
 - Another unit of energy
 - Calorie = 4 kJ (a little c-calorie is only 4 J)
 - 2000 Calories = 10 MJoules
 - 10 MJ/day = $10^7 / (24 \cdot 60 \cdot 60) \sim 100\text{W}$ (power you put out)
 - 30% is your brain, so your brain uses around 30W

Energy Flow

- The power associated with the red box is:
 - $1\text{ A} \cdot 5\text{ V} = 5\text{ W}$
- Is the box generating or consuming this power?
 - Every charge that enters, also leaves
 - Charge neutral
 - **Does the charge leave with more or less potential energy?**
 - More is higher voltage, less is lower voltage
 - If it leaves from the
 - Lower voltage lead – energy was lost;
 - The box consumed some energy
 - Higher voltage lead – energy was gained;
 - The box supplied energy

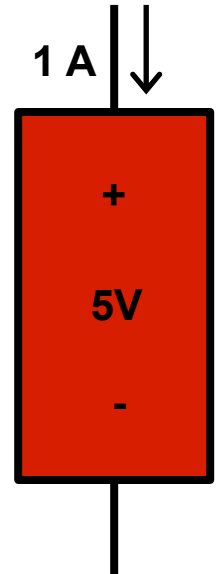

Energy Flow

- What generate/dissipates energy
 - The 5 V voltage supply
 - The red box

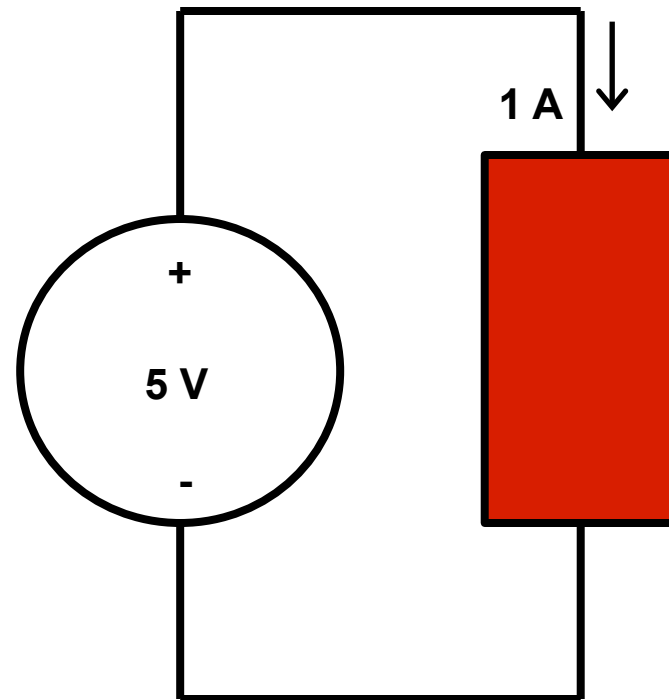

Find the Power Dissipated In Each Device

- First figure out which lead has the higher voltage
 - Then figure out whether current flows into or out of that lead

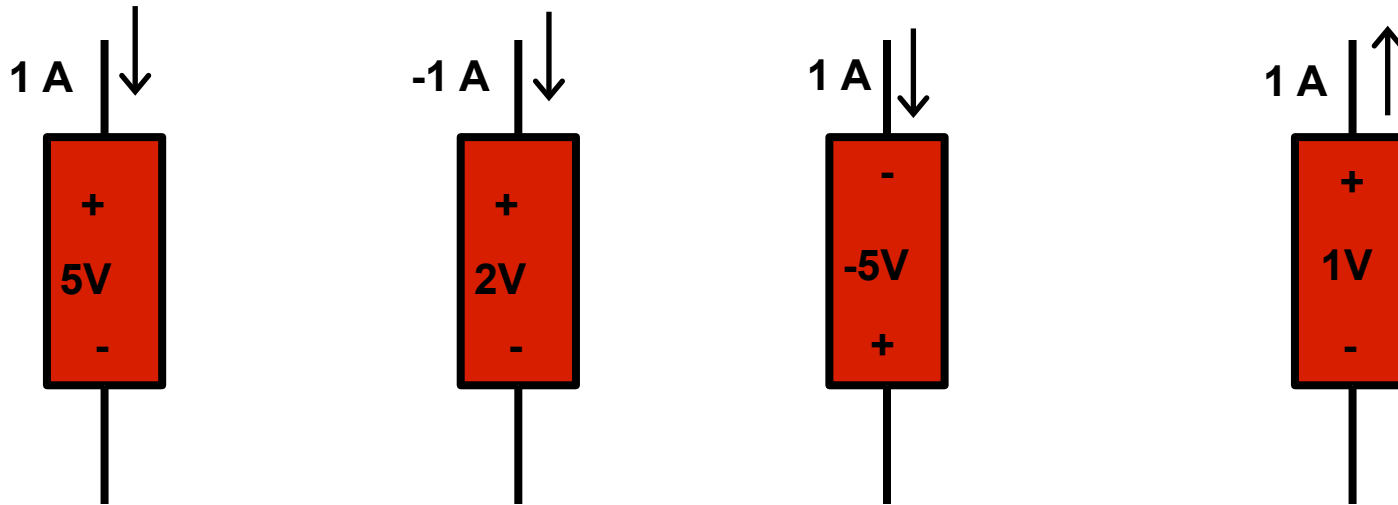

Learning Objectives – KCL, KVL, Energy Flow

- Sum of voltage drop around any loop of devices is always 0 (KVL); sum of currents into any node is always 0 (KCL).
- The power consumed by a device is always:
 - The current flowing into the + terminal multiplied by
 - The voltage across the device.
- A voltage source is an electrical device where $V = V_{\text{source}}$ and the current is determined by the rest of the circuit
- Learn SI prefixes