E40M

RC Filters

Reading

- Reader:
 - The rest of Chapter 7
 - 7.1-7.2 is about log-log plots
 - 7.4 is about filters

- A & L
 - 13.4-13.5

EKG (Lab 4)

- Concepts
 - Amplifiers
 - Impedance
 - Noise
 - Safety
 - Filters
- Components
 - Capacitors
 - Inductors
 - Instrumentation and Operational Amplifiers

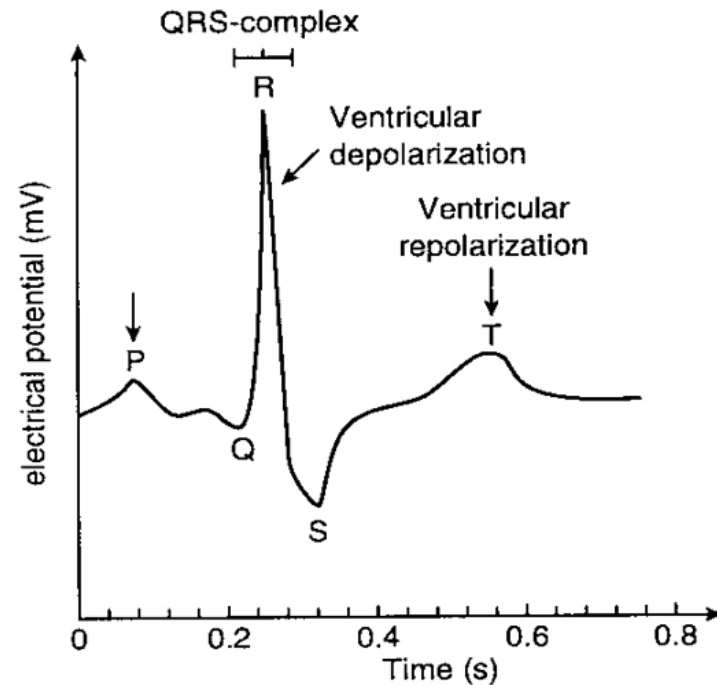

In this project we will build an electrocardiogram (ECG or EKG). This is a noninvasive device that measures the electrical activity of the heart using electrodes placed on the skin.

RC Circuit Analysis Approaches

1. For finding voltages and currents *as functions of time*, we solve linear differential equations or run EveryCircuit.
2. For finding the response of circuits to *sinusoidal signals*,* we use impedances and “frequency domain” analysis

*superposition can be used to find the response to any periodic signals

Key Ideas on RC Circuit Frequency Analysis - Review

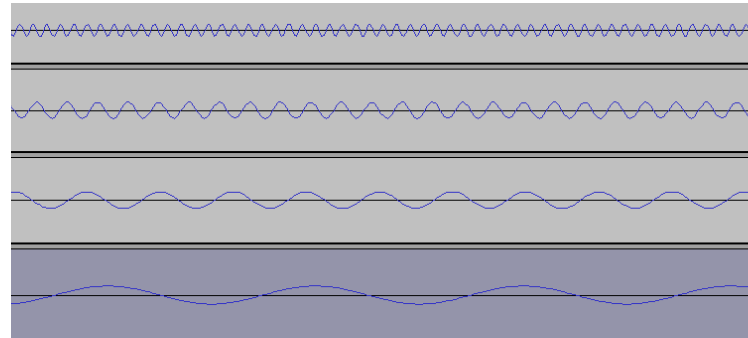
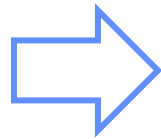
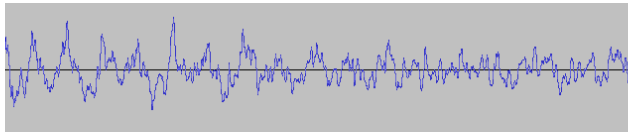

- All voltages and currents are sinusoidal
- So we really just need to figure out
 - What is the amplitude of the resulting sinewave
 - And sometimes we need the phase shift too (but not always)
- These values don't change with time
 - This problem is very similar to solving for DC voltages/currents

Key Ideas on Impedance - Review

- Impedance is a concept that generalizes resistance:
 - For sine wave input

$$Z = \frac{\text{mag}(V)}{\text{mag}(i)}$$

Add j to represent 90° phase shift

- Z for a resistor is just R
 - It does not depend on frequency, it is simply a number.

- What about a capacitor?

$$Z_C = \frac{V}{i} = \frac{V}{CdV/dt} = \frac{V_0 \sin(2\pi Ft)}{2\pi FCV_0 \cos(2\pi Ft)}$$

$$Z_C = \frac{V}{i} = \frac{1}{j * 2\pi FC}$$

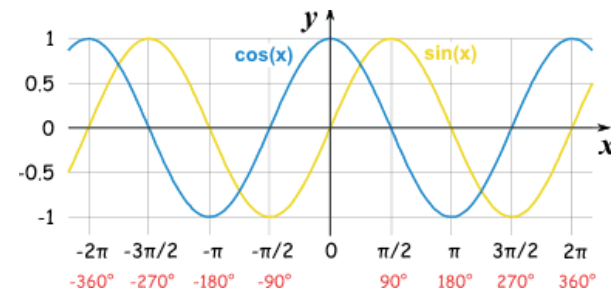

Analyzing RC Circuits Using Impedance - Review

- The circuit used to couple sound into your Arduino is a simple RC circuit.
- This circuit provides a DC voltage of $V_{dd}/2$ at the output.
- For AC (sound) signals, the capacitor will block low frequencies but pass high frequencies. (High pass filter).
- For AC signals, the two resistors are in parallel, so the equivalent circuit is shown on the next page.

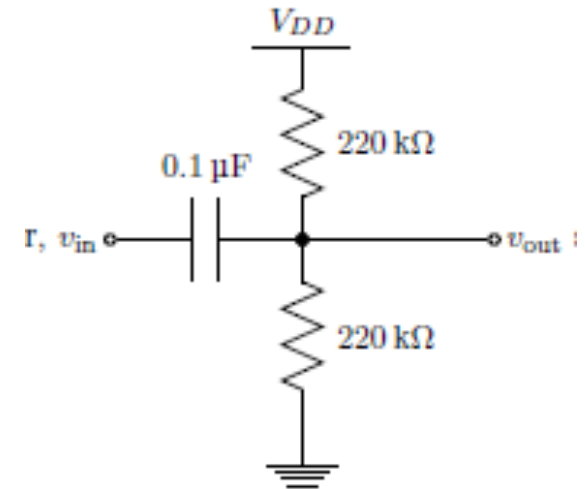

Analyzing RC Circuits Using Impedance – Review (High Pass Filter)

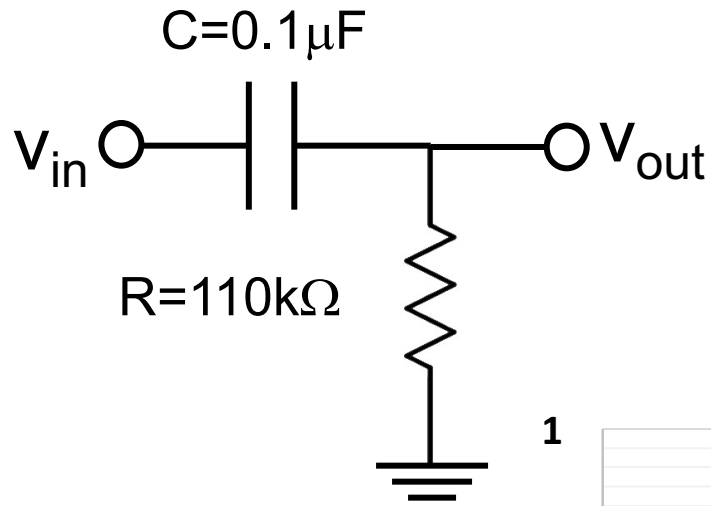

$$\frac{V_{out}}{V_{in}} = \frac{R}{R + \frac{1}{j * 2\pi FC}} = \frac{j * 2\pi FRC}{1 + j * 2\pi FRC}$$

$RC = 11 \text{ ms}$; $2\pi RC$ about 70 ms

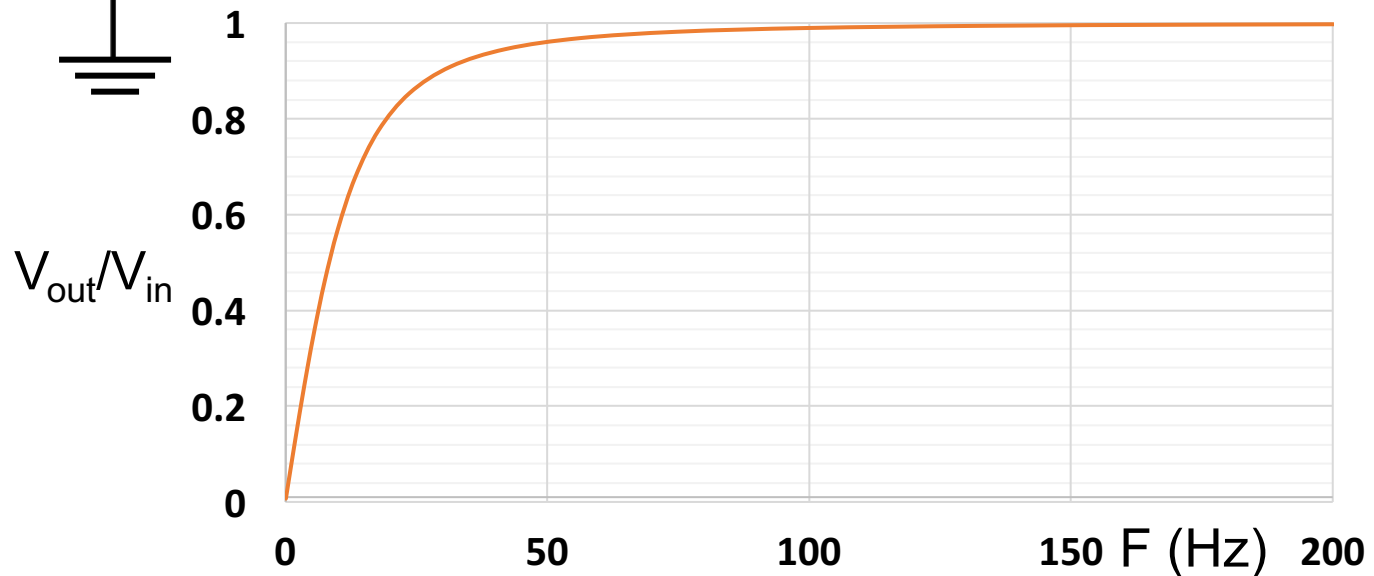

RC FILTERS

RC Circuits Can Make Other **Filters**

- Filters are circuits that change the relative strength of different frequencies
- Named for the frequency range that passes through the filter
 - Low pass filter:
 - Passes low frequencies, attenuates high frequency
 - High pass filter
 - Passes high frequencies, attenuates low frequencies
 - Band pass filter
 - Attenuates high and low frequencies, lets middle frequencies pass

RC Low Pass Filters

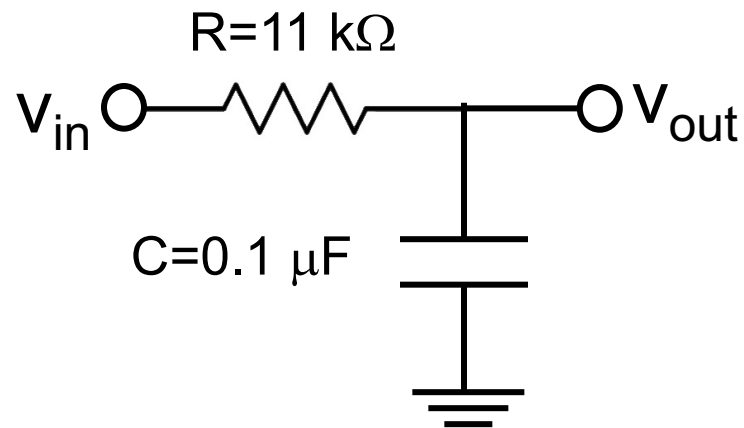

- Let's think about this before we do any math

- Very low frequencies \rightarrow

$$\begin{aligned} RC &= 11 \times 10^3 \times 0.1 \times 10^{-6} \text{ s} \\ &= 1.1 \text{ ms} \end{aligned}$$

$$2\pi RC = 6.9 \text{ ms}$$

$$1/(2\pi RC) = 145 \text{ Hz}$$

- Very high frequencies \rightarrow

RC Low Pass Filters

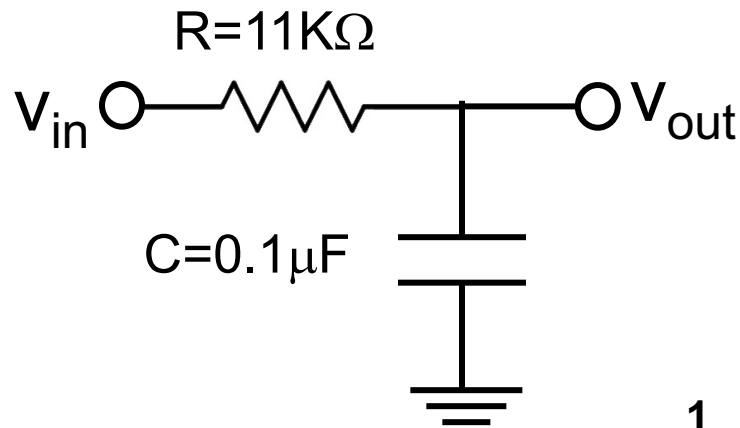

$$\frac{V_{\text{out}}}{V_{\text{in}}} = \frac{1}{R + \frac{1}{j*2\pi FC}} = \frac{1}{1 + j*2\pi FRC} = \frac{1}{1 + jF/F_c}$$

$$F_c = 1/[2\pi RC]$$

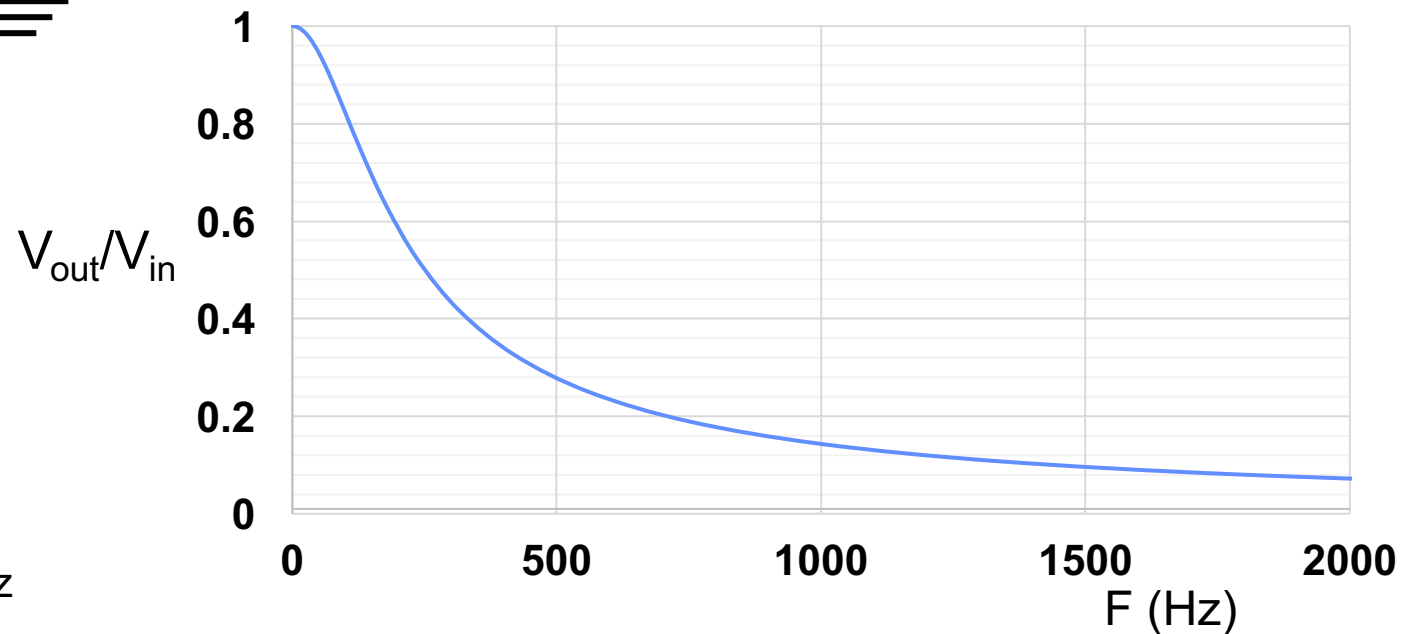

$RC = 1.1 \text{ ms}$
 $F_c = 1/[2\pi RC] = 145 \text{ Hz}$

RC Filters – Something a Little More Complicated

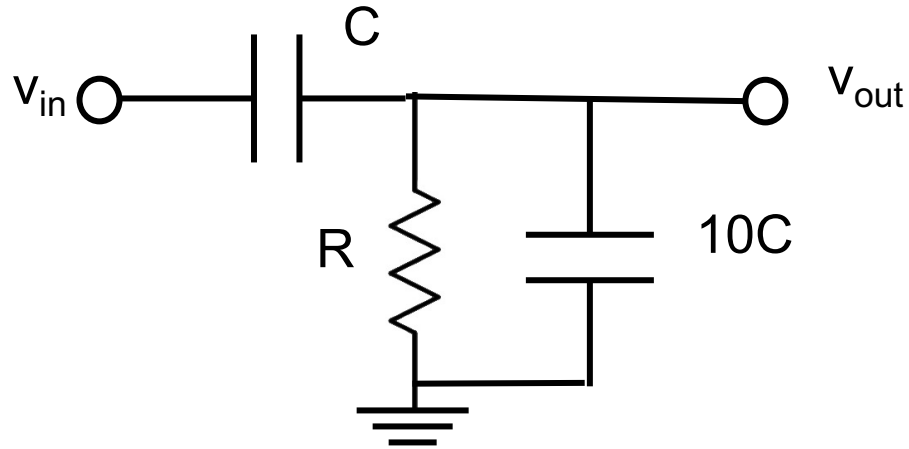

- Let's think about this before we do any math
- Very low frequencies →
- Very high frequencies → capacitive divider

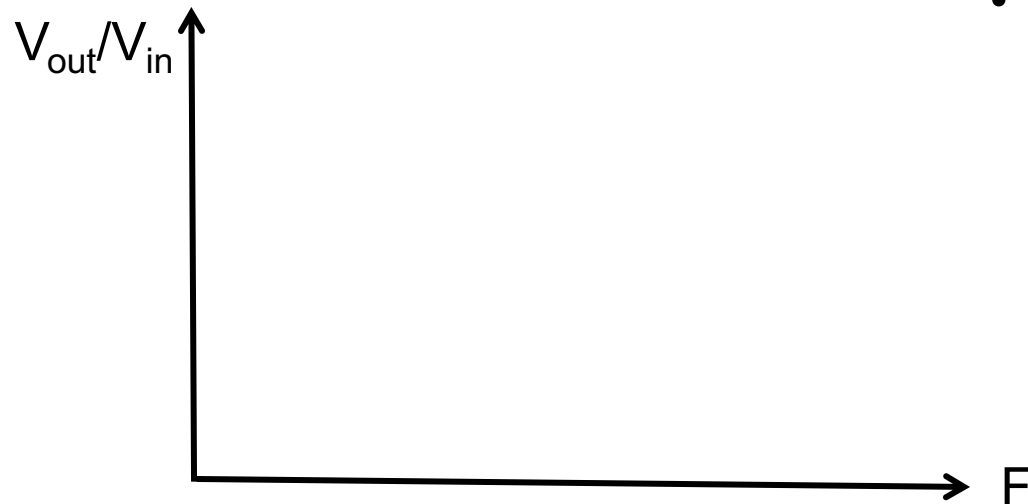

RC Filters – Something More Complicated

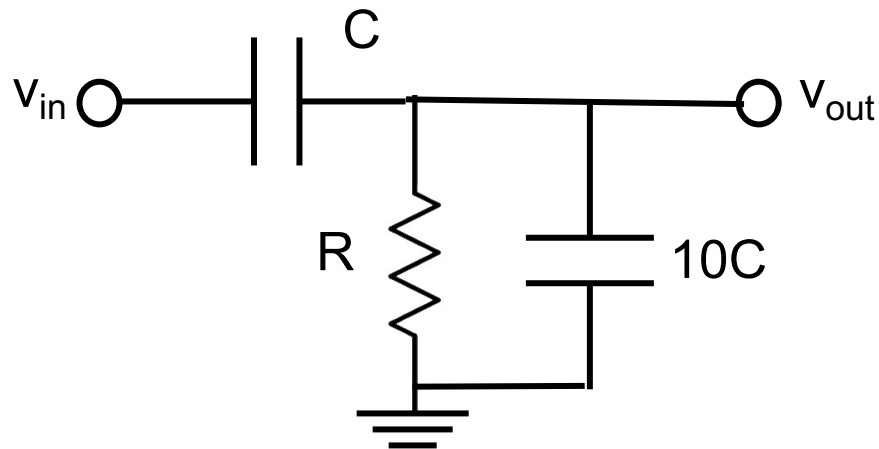

$$Z_1 = \frac{1}{j * 2\pi F C}$$

$$Z_2 = \frac{1}{\frac{1}{R} + j * 2\pi F 10C} = \frac{R}{1 + j * 2\pi F 10RC}$$

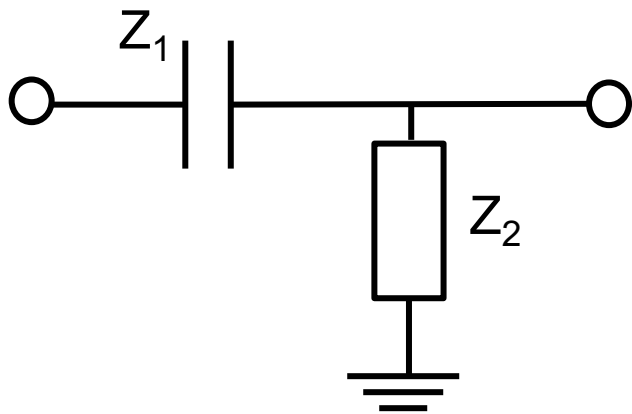

$$\frac{V_{out}}{V_{in}} = \frac{\frac{R}{1 + j * 2\pi F 10RC}}{\frac{R}{1 + j * 2\pi F 10RC} + \frac{1}{j * 2\pi F C}}$$

$$= \frac{j * 2\pi F R C}{j * 2\pi F R C + (1 + j * 2\pi F 10RC)} = \frac{j * 2\pi F R C}{1 + j * 2\pi F 11RC}$$

RC Filters – Something More Complicated

$$\frac{V_{out}}{V_{in}} = \frac{j*2\pi FRC}{1+j*2\pi F11RC} \rightarrow \text{Simplify using } F_c = 1 / [2\pi R11C] = 13 \text{ Hz}$$

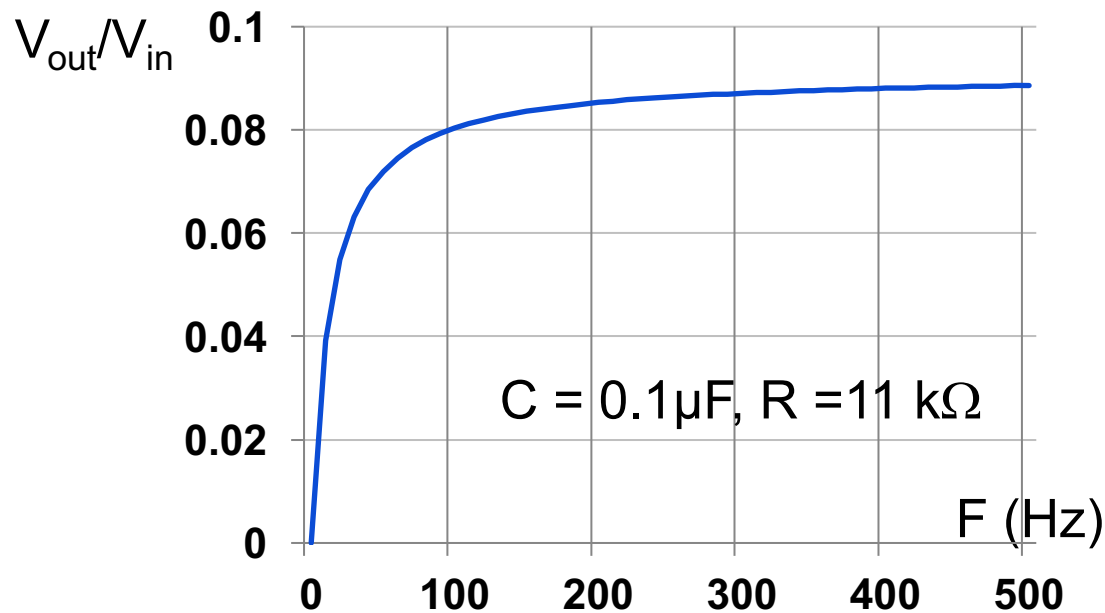

What If We Combine Low Pass and High Pass Filters?

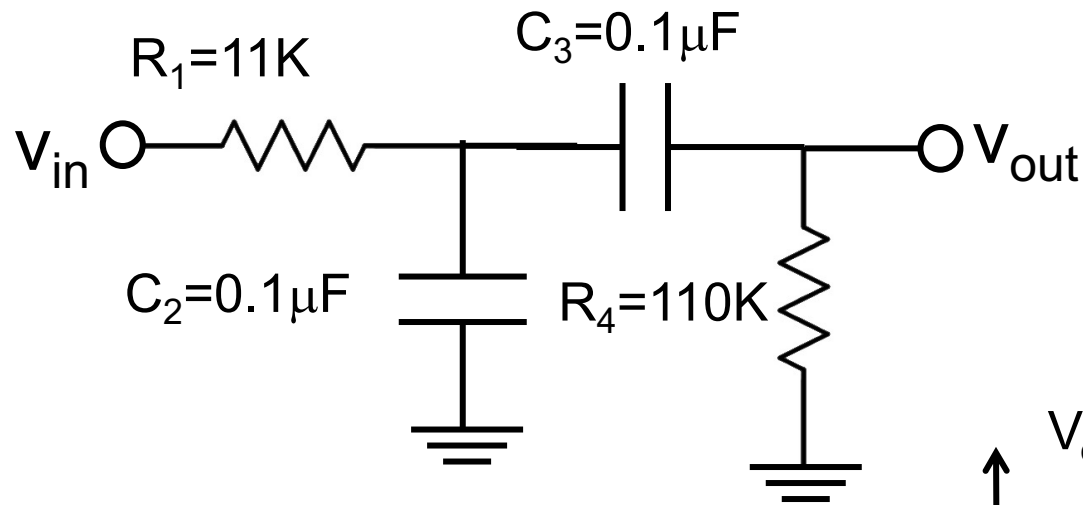

- What do you think it will do?
- We'll use a filter that operates like this in the ECG lab project.

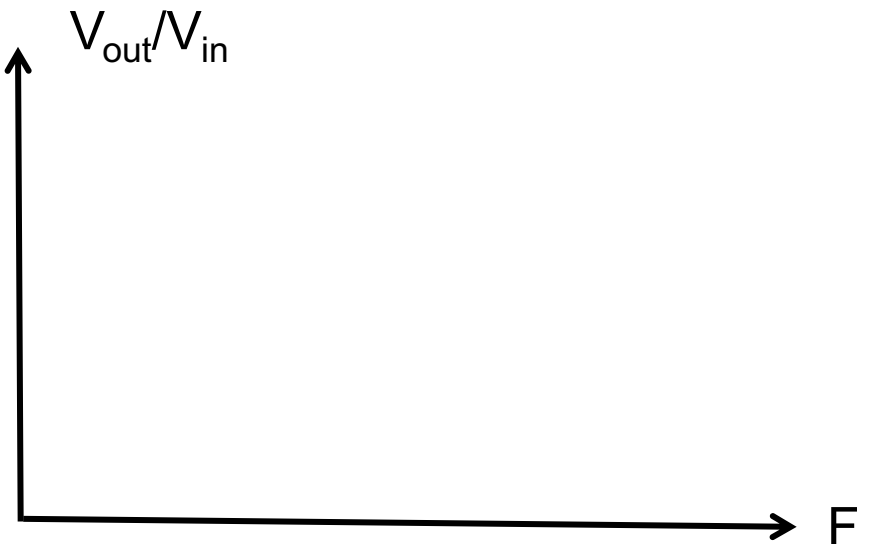

Analysis Options: Nodal Analysis

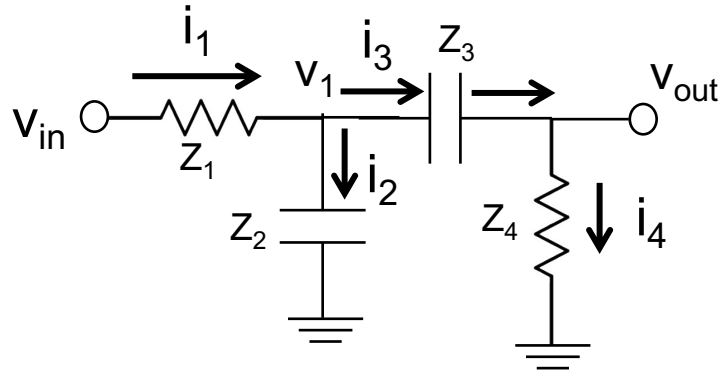

- Let's first solve it using Z_1 - Z_4 and nodal analysis

$$i_3 = i_4 \quad \therefore \frac{V_{\text{out}} - V_1}{Z_3} = \frac{V_{\text{out}}}{Z_4} \quad \therefore V_{\text{out}} = V_1 \frac{Z_4}{Z_3 + Z_4}$$

$$i_1 = i_2 + i_3 \quad \therefore \frac{V_1 - V_{\text{in}}}{Z_1} = \frac{V_1}{Z_2} + \frac{V_1 - V_{\text{out}}}{Z_3}$$

- We have 2 equations in 2 unknowns (V_1 and V_{out}). So we could solve this for $V_{\text{out}}/V_{\text{in}}$ in terms of the impedances.

Analysis Options: Using R, C and Voltage Dividers

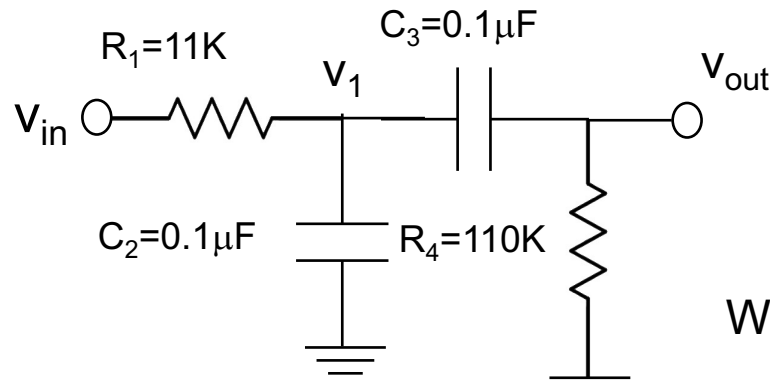

For convenience, let $s = j*2\pi F$

$$\frac{V_{out}}{V_1} = \frac{R_4}{R_4 + \frac{1}{sC_3}} = \frac{sR_4C_3}{1 + sR_4C_3}$$

We can replace R_4 , C_3 and C_2 with Z_{eqv}

$$Z_{eqv} = \frac{1}{\frac{1}{R_4 + \frac{1}{sC_3}} + sC_2} = \frac{1}{\frac{sC_3}{1 + sR_4C_3} + sC_2} = \frac{1 + sR_4C_3}{sC_2 * \left(\frac{C_3}{C_2} + 1 + sR_4C_3 \right)}$$

$$\therefore \frac{V_1}{V_{in}} = \frac{\frac{1 + sR_4C_3}{sC_2 * \left(\frac{C_3}{C_2} + 1 + sR_4C_3 \right)}}{R_1 + \frac{1 + sR_4C_3}{sC_2 * \left(\frac{C_3}{C_2} + 1 + sR_4C_3 \right)}} = \frac{1 + sR_4C_3}{1 + sR_4C_3 + sR_1C_2 * \left(\frac{C_3}{C_2} + 1 + sR_4C_3 \right)}$$

Output Response

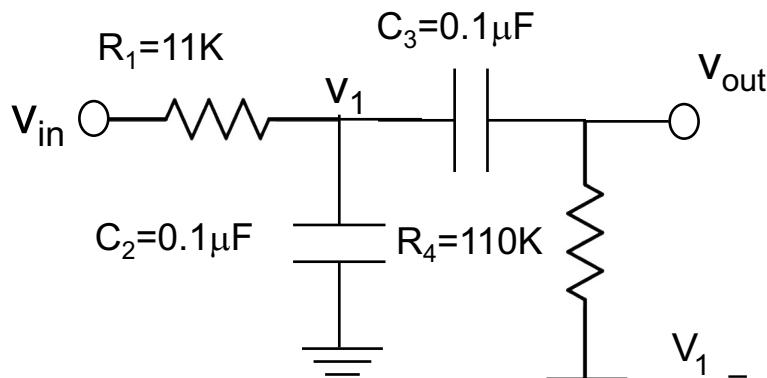

$$\frac{V_{out}}{V_1} = \frac{R_4}{R_4 + \frac{1}{sC_3}} = \frac{sR_4C_3}{1 + sR_4C_3}$$

$$\frac{V_1}{V_{in}} = \frac{\frac{1 + sR_4C_3}{sC_2 * \left(\frac{C_3}{C_2} + 1 + sR_4C_3\right)}}{R_1 + \frac{1 + sR_4C_3}{sC_2 * \left(\frac{C_3}{C_2} + 1 + sR_4C_3\right)}} = \frac{1 + sR_4C_3}{1 + sR_4C_3 + sR_1C_2 * \left(\frac{C_3}{C_2} + 1 + sR_4C_3\right)}$$

$$\frac{V_{out}}{V_1} \cdot \frac{V_1}{V_{in}} = \frac{sR_4C_3}{1 + sR_4C_3 + sR_1C_2 * \left(\frac{C_3}{C_2} + 1 + sR_4C_3\right)} = \frac{sR_4C_3}{1 + s(R_4C_3 + R_1C_2 + R_1C_3) + s^2R_1C_2R_4C_3}$$

$$\text{Or, } \frac{V_{out}}{V_{in}} = \frac{j * 2\pi F R_4 C_3}{1 + j * 2\pi F (R_4 C_3 + R_1 C_2 + R_1 C_3) + (j * 2\pi F)^2 R_1 C_2 R_4 C_3}$$

Output Response

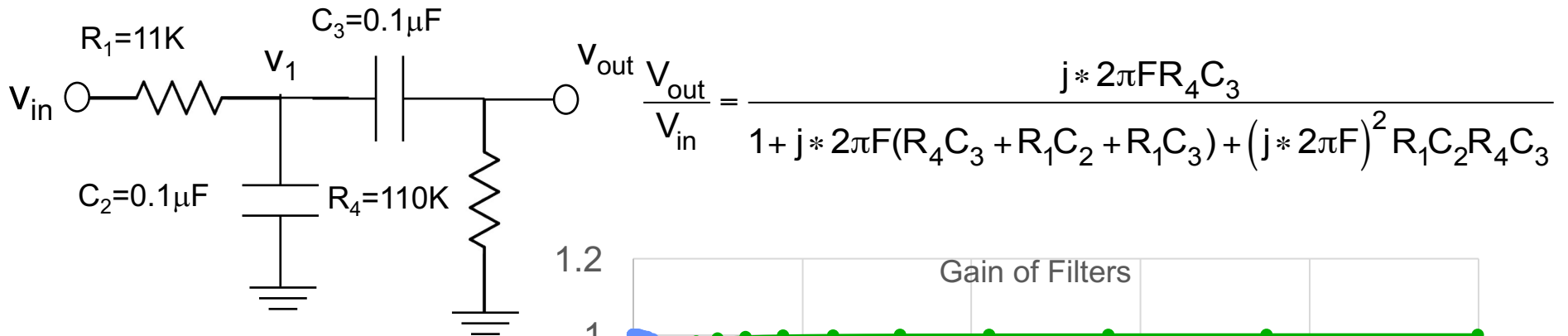

$$\frac{V_{out}}{V_{in}} = \frac{j * 2\pi F R_4 C_3}{1 + j * 2\pi F (R_4 C_3 + R_1 C_2 + R_1 C_3) + (j * 2\pi F)^2 R_1 C_2 R_4 C_3}$$

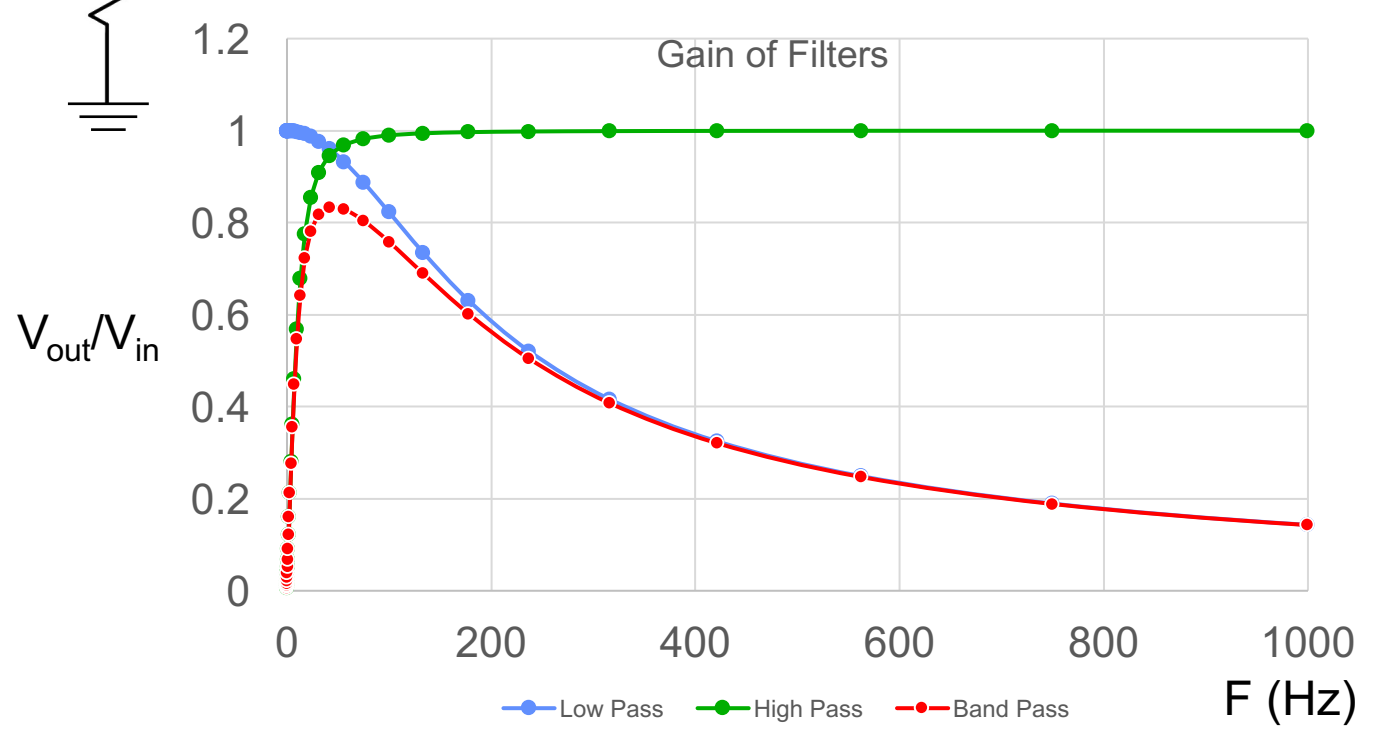

So What Are The Answers To These Questions?

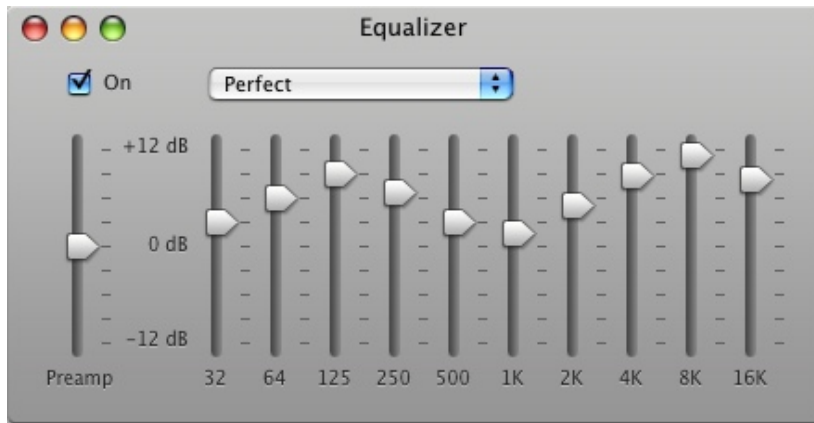

How do we design circuits that respond to certain frequencies?

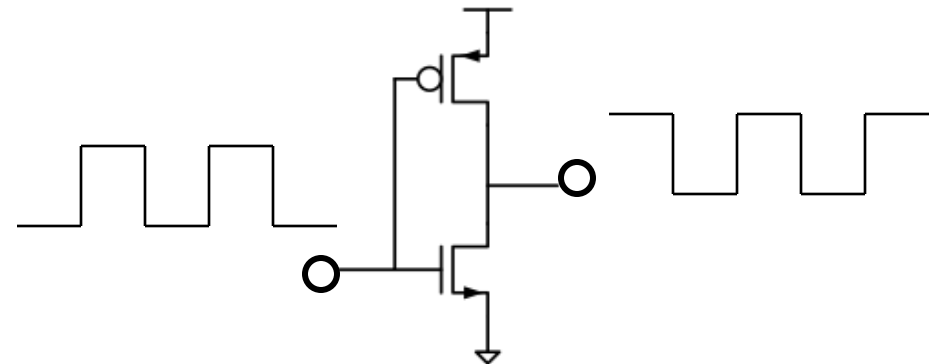

What determines how fast CMOS circuits can work?

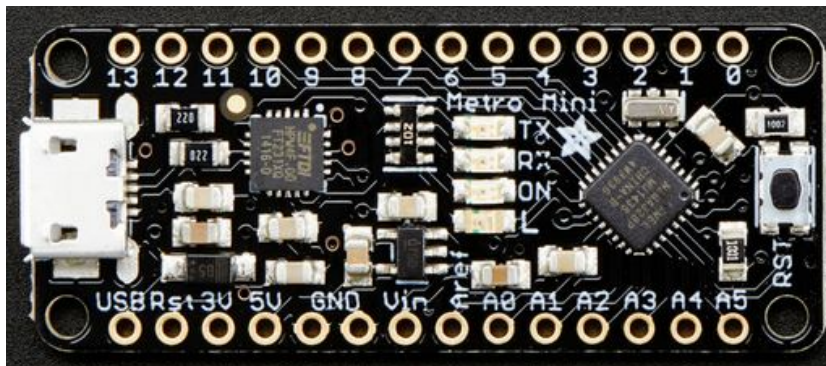

Why did you put a 200 μF capacitor between Vdd and Gnd on your Arduino?

Learning Objectives

- Become more comfortable using impedance
 - To solve RC circuits
- Understand how to characterize RC circuits
 - Which are low pass, high pass and bandpass filters
- Be able to sketch the frequency dependence of an RC circuit by reasoning about how capacitors behave at low and high frequencies