

EE133 - Prelab 3

The Low-Noise Amplifier

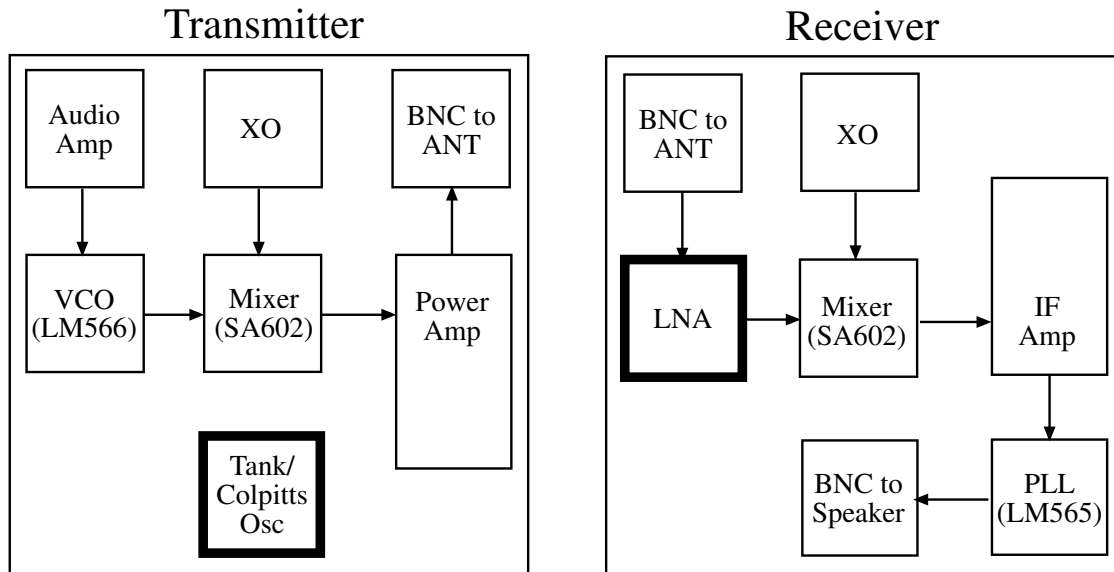

Figure 1: Lab 3 Roadmap

1 Introduction

This week, you will be building a low-noise preamplifier for the front end of your FM receiver. The input to this amplifier will be signals from an antenna, which we will model as a voltage source with a 50Ω source impedance. Although this may sound like a straightforward task, there are a number of complicating issues involved with processing a low-power, high frequency signal that we must keep in mind. These issues - noise, bandwidth, gain, and impedance matching - will apply to our entire transceiver system, but for now we shall frame them in the context of designing our low-noise amplifier:

1.1 Noise

There are a few different kinds of noise that tend to cause trouble in almost any electronic system. We will discuss these different types in more detail throughout the quarter. In some cases we will have some control over how much noise is present in the system, and in other cases, we won't. Two of the main types of noise are thermal, or 'Johnson', noise (due to random movements of electrons in a solid, so-called 'Brownian motion'), and shot noise (due to current through an active diode or bipolar device). Both of these have constant average values over frequency, and so both are limited by the bandwidth of the system. Clearly we wish to minimize noise as much as possible in our amplifier design (hence, the 'low-noise' designation).

1.2 Bandwidth

For communications systems, we are concerned with bandwidth for a number of reasons. Usually we think of bandwidth as being related to the amount of information that can be transmitted in a given system in a given amount of time. For high-frequency transmission, the concept of bandwidth has a few more implications. As noted above, the total noise in a system is related to the bandwidth of the system, and so a large bandwidth will generally yield a large amount of background noise. In communications systems, we are often concerned with transmission and reception in a certain frequency band, and so we use filters and tuned (resonant)

circuits to limit signals (and noise) to these bands. Our amplifier on its own will be broadband, but tuned matching on the output and (later) filtering on the input will provide this band-limiting for the amplifier.

1.3 Gain

We would like our receiver to be able to distinguish very small input signals (on the order of μV !), and so we will need our amplifier to supply an appreciable amount of gain to boost the signal enough that it can be processed by the succeeding stages. The main concern here is noise. As we will find, each block in the system contributes noise that propagates through to the output. In addition, the noise contributed by the first stage can have a much larger impact on the overall noise of the system than the noise added by the succeeding stages. In addition, the gain of the first stage also tends to reduce the effect of noise contributed by subsequent stages. Therefore we would like to get as much gain as possible out of the first stage of the receiver. This could come at the cost of dynamic range at the input (i.e. large input signals will saturate the output of the amplifier). Because we are concerned mostly with reception at long distances (therefore small input signals), however, this shouldn't be an issue.

1.4 Impedance Matching

Because we are dealing with very small signals in our receiver, we would like to have maximum power transfer from block to block. In most (but not all) cases, this translates to having conjugate impedance matches between stages. We will try to match the input and output impedance of our amplifier to a standard value of 50Ω , which is the value of the output impedance of most RF test equipment. This will allow you to characterize each block easily. For cases in which we cannot have a 50Ω impedance, we will use the active probe to take measurements.

2 Warm-up Exercises

Before we dive into our amplifier design, let's get a few important tools in hand.

2.1 Impedance Measurements - S-parameters

In practical situations, it is extremely difficult to measure impedance by trying to determine the current through a node for an applied voltage. It's relatively easy, however, to measure incident and reflected waves. Therefore, borrowing from transmission line theory, we can obtain the input and output impedances of a circuit simply by measuring the input and output reflection coefficients. You will use the network analyzer in the lab to measure impedances this way. In addition, we can also obtain information about the forward and reverse transmission characteristics of the circuit and express all of this information as a matrix of parameters, known as the scattering matrix (the parameters are then the S-parameters). The S-parameters are defined as:

$$S_{11} = \left. \frac{V_1^-}{V_1^+} \right|_{V_2^+=0}$$

$$S_{12} = \left. \frac{V_1^-}{V_2^+} \right|_{V_1^+=0}$$

$$S_{21} = \left. \frac{V_2^-}{V_1^+} \right|_{V_2^+=0}$$

$$S_{22} = \left. \frac{V_2^-}{V_2^+} \right|_{V_1^+=0}$$

Or, in general,

$$S_{ij} = \frac{V_i^-}{V_j^+} \Big|_{V_k^+ = 0 \text{ for } k \neq j}$$

Recall that for some characteristic impedance, Z_0 , $\Gamma = \frac{Z_L - Z_0}{Z_L + Z_0}$. Therefore, S_{11} is simply Γ , the reflection coefficient, at the input of a network, and S_{22} is Γ at the output. We can then find the input and output impedance of a given network simply by measuring these two quantities. (See Chapter 8, Section 8.4-8.8 in Radmanesh, or lecture notes, for more information).

EXERCISES:

1. For a $Z_0 = 50\Omega$ characteristic impedance, what is Z_L if $S_{11} = .6 + .2i$?
2. Compute S_{11} for an amplifier with input impedance of $Z_{in} = 100\Omega$. The voltage source resistance is $Z_s = 75\Omega$.

2.2 The Smith Chart

The Smith Chart has become an essential tool for designing RF and microwave systems. Even with the advent of computer-aided design, Smith Charts find their place in design of impedance matches, gain calculations, and even determination of stability of RF networks (indeed, many measurement instruments and design software include a Smith Chart display). In the simplest sense, the Smith Chart is a polar plot of the reflection coefficient, Γ , including some extra lines to describe values of Γ for which the real and imaginary parts of the load impedance are constant (as seen above, Γ is related to the load impedance for a fixed value of Z_0 .) Although we will not be using Smith Charts extensively in this class, we would like you to have a basic understanding of them and to be able to work with them in the lab via the network analyzer. Read through the lecture notes (Chapter 9 in Radmanesh) and do the following problems (taken from Radmanesh, p.337).

EXERCISES:

1. (Problem 9.1) What is a standard Smith chart? What range of resistor and reactive values is mapped into a standard Smith chart?
2. (Problem 9.4) Using a Smith chart, find Z_L for:
 - (a) $\Gamma = 0.6e^{j45^\circ}$
 - (b) $\Gamma = -0.3$
 - (c) $\Gamma = 0.4 + j0.4$

3 The Low-Noise Amplifier

Now we can focus on designing the LNA, shown in Figure 2. This amplifier is configured with ‘shunt-shunt’ feedback (more on what this means in a bit).

3.1 DC Characteristics

Before we get too overwhelmed by this circuit, let’s try and simplify things a bit by looking at the DC characteristics of the circuit. In DC terms, this looks exactly like a typical common emitter amplifier, and therefore, one can calculate bias values in the same way as one would for a CE amplifier. The capacitors in the circuit all become open circuits at DC, and so the complicated circuit reduces to the relatively simple biasing situation seen in Figure 3. There are a few points to keep in mind when designing the DC bias for this circuit:

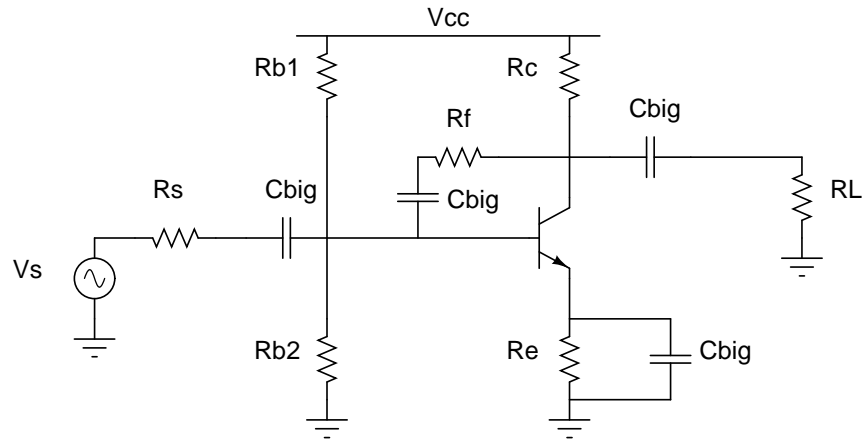

Figure 2: The Shunt-Shunt Low-Noise Amplifier

- Bias Resistors:** As will become apparent in discussion of the AC characteristics of this amplifier, we wish the parallel combination of the input bias resistors ($R_{b1} // R_{b2}$) to be large compared to our intended input (50Ω) so that they do not load the amplifier. At the output, we wish R_c to be large compared to 50Ω . As an example, $1k\Omega$ in parallel with 50Ω yields an effective impedance of about 47.6Ω . Bias currents will mostly constrain these values, but we should be aware of this issue and confirm that these resistors do not load the amplifier too much.
- Input Signal:** The expected input signal will be very small for large distances (on the order of μV), so we needn't center the input and output between the supply voltages. Normally we might do this to ensure maximum dynamic range at the input or output.
- Transistor Bias Voltage:** In addition to biasing the transistor with a certain amount of current, it is important to provide sufficient collector emitter voltage to ensure that the transistor operates linearly.
- Input Bias Current:** Remember that BJTs have some finite input bias current. Therefore we will need the bias resistor chain to have relatively large current compared to this base current. Otherwise the characteristics of the amplifier will depend on the characteristics of the particular transistor used.

3.2 AC Characteristics

Around the resonant frequency, the capacitors (C_{big}) will become short circuits and the amplifier will reduce to the circuit shown in Figure 4. To investigate the AC characteristics of this amplifier further, we will need to digress into a discussion of shunt-shunt feedback.

3.3 Shunt-Shunt Feedback

Feedback theory can be a powerful tool in circuit design when it is employed correctly. Unfortunately, it is not always straightforward to do so, and often analyzing a circuit brute force proves more feasible. In this section, we provide an overview of our LNA circuit in terms of feedback theory. Don't worry if this seems confusing or convoluted. We present it here as an alternative way to looking at feedback circuits. The general concepts are useful to understand, but the implementation of the tool can be somewhat cumbersome.

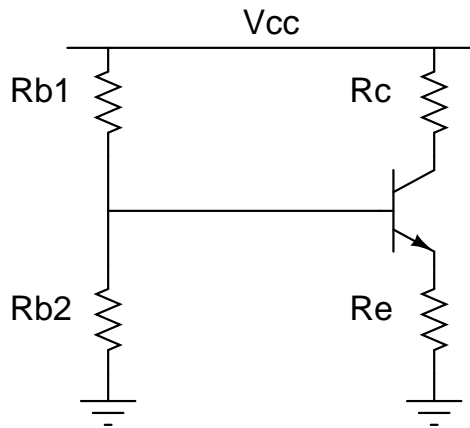

Figure 3: Amplifier DC Equivalent Circuit

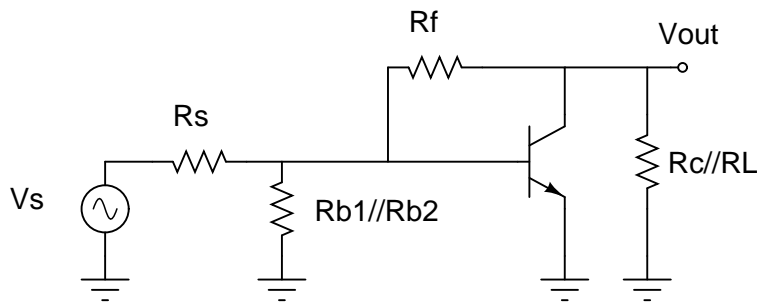

Figure 4: Amplifier AC Equivalent Circuit

The term shunt-shunt feedback comes from a description of how the signal is sensed at the output and fed back to the input. In our amplifier, for example, we are sensing the voltage at the output and feeding back a current to the input. Sensing the output voltage is akin to placing our ‘sensor’ in parallel with the output, hence shunting it. Feeding a current to the input is then akin to placing a current source in parallel with the input. If we were feeding back a voltage, this voltage would be in series with the input, and so we would call this a series-shunt feedback system. Figure 5 shows the typical two-port model for a shunt-shunt feedback situation.

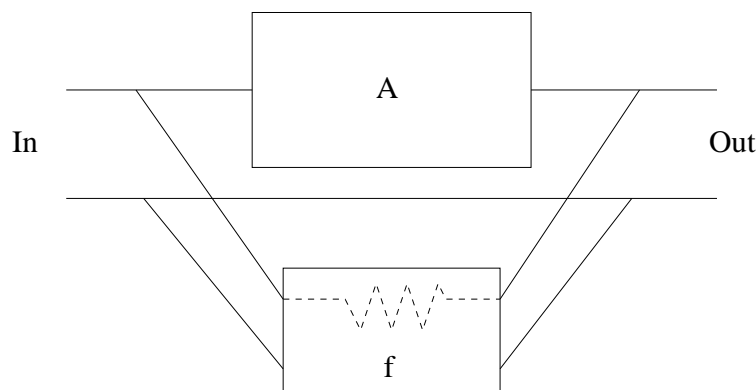

Figure 5: Shunt-Shunt Two-Port Model

Because there are entire books written on feedback theory, it might be a little presumptuous to attempt to explain the details here in this prelab. Instead we present the salient points for our shunt-shunt feedback

system:

- **Input Impedance:** Shunt feedback to the input always lowers the value of the input impedance (This should make sense, since we are placing some equivalent impedance in parallel with the input impedance). Relative to the open-loop input impedance, then, our new input impedance can be expressed as:

$$Z_{in} = \frac{Z_{inOL}}{1 + Af}$$

Because we are shunting the input impedance with another impedance, the new effective impedance is lower. Notice that this is good for us, because we want to bring the input impedance of our amplifier (which is on the order of $r_{\pi} = \frac{\beta}{g_m} = 1k\Omega$) down to near 50Ω .

- **Output Impedance:** Similarly, shunt feedback at the output also has the effect of decreasing the output impedance by the same factor. That is,

$$Z_{out} = \frac{Z_{outOL}}{1 + Af}$$

- **The Open Loop Gain, A** One tricky thing about analyzing feedback systems this way is calculating the correct value of the gain A. First of all, because we are sensing an output voltage and feeding back a current, the gain A is actually a transresistance (i.e. $A = V_{out}/I_{in}$). In addition, one might be tempted to simply use the gain of the amplifier without R_f as A, but this is not always correct. If the feedback network loads the amplifier (as it certainly does in our case), then you must include the effects of the effective input and output impedance presented by the feedback network at the input and output of the amplifier. With a simple resistor in the feedback loop, it turns out that our amplifier is loaded on both sides by R_f to ground, as shown in Figure 6. Recall that we have also included R_{eq} at the output, which is the parallel combination of R_t , the tank impedance of our LC tank, and R_L , the input impedance of the next stage. Note also that, **in terms of this feedback analysis, we must include R_f and R_{eq} when we calculate Z_{inOL} and Z_{outOL} .**

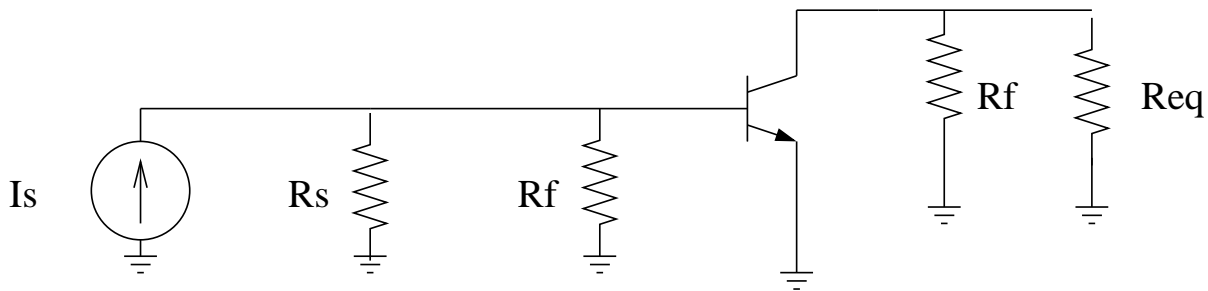

Figure 6: Equivalent Amplifier Loaded by Feedback Resistor

- **The Total Gain:** The total gain for this amplifier can be calculated exactly, using the small signal model for the BJT and tracing through node equations. With the feedback model, however, we can show that the total closed loop gain will be equal to

$$\frac{V_{out}}{I_s} = \frac{A}{1 + Af}$$

where A is the loaded open loop gain and f is $-\frac{1}{R_f}$ (Note that A is negative, so we still have a positive Af product in the denominator). Notice that to get voltage gain, we must further divide this by

$(R_s // R_{in})$, so that

$$\frac{V_{out}}{V_{in}} = \frac{A}{(R_s // R_{in})(1 + Af)}$$

- **Note on Impedances:** Notice in our derivation for the input and output impedances that we have included both R_s and R_{eq} in our expression for A and our Z_{OL} expressions. Let's focus on the input impedance for a moment. Because we have included R_s in our calculation of the input impedance, then we have actually included the source impedance in the input impedance of our amplifier. If we want to find out what the amplifier input impedance is, then, we have to subtract out the source impedance. The easiest way to do this is using admittances:

$$\frac{1}{Z_{without R_s}} = \frac{1}{Z_{with R_s}} - \frac{1}{R_s}$$

A similar approach can be taken to subtract out the load impedance from the calculated output impedance.

4 Designing the LNA

Now let's try to put all of this together and design our low-noise amplifier. The lecture notes give an almost exact derivation, and here we will decipher the variables for our amplifier.

1. **Calculate the Gain:** Draw out the small-signal model for this amplifier, neglecting C_π and C_μ , and calculate the voltage gain. You may want to refer to expressions derived in the lecture notes.
2. **Calculate the Input and Output Impedances:** Using the small signal model, find expressions for the input and output impedances for the amplifier. Again, refer to the lecture notes for the relevant expressions if you get stuck. Recall that to find the input impedance, we apply a test voltage or current source to the input of this amplifier and figure out what test current/voltage develops. The input impedance is then the ratio of the test voltage to the test current. To find the output impedance, apply a test source to the output and disable the input (for a voltage source, this means shorting the source. A current source becomes an open circuit.) Feel free to neglect any parasitic capacitances.
3. **Design your Amplifier:** Design an amplifier to meet the following specifications using the 2NSC3302. You may assume $\beta = 75$ although you should still look at the spec sheet. Note that it might be helpful to do your calculations in Matlab or a spreadsheet so that you can adjust values easily. What value of Rf will allow you to meet the desired input impedance?

(a) **Specifications:**

- Supply Rails: 0V and 9V
- Input Impedance (R_{in}): 50Ω
- Output Impedance (R_{out}): 50Ω
- $S_{21} > 12dB$
- Collector Current (I_C): 4mA
- Collector-Emitter Voltage (V_{CE}): $> 1V$
- Power consumption: as small as possible.

- (b) **DC Bias Points:** The current through the transistor will essentially be set by the resistor R_E and the DC voltage at the emitter (which is one diode drop below the base voltage). Once a base voltage or collector voltage is chosen, the DC values should be relatively set. Notice that you can choose a relatively low base voltage, since the input signal will in general be very small. This may give you more play with your values of Rc and Re, but be aware that it will also make the effect of Rbias larger at the input ($R_{b1} // R_{b2}$ will be smaller).

- (c) **AC Parameters:** Note that the AC performance (i.e. the feedback) of this circuit is completely decoupled from its DC performance. That is, you can change the feedback resistor R_F without changing the DC operating points. What value of R_F gives you input and output impedances close to 50Ω ? How are the input/output impedances affected by the bias resistors? What gain do you expect for this circuit?
- (d) **A Note on DC Blocking Capacitors:** One would normally choose C_{big} such that the reactance (i.e. $\frac{1}{\omega C}$) of the capacitors are small at 24.3MHz. Usually this means the impedance should be approximately $j1\Omega$ or less. The self-resonance of physically constructed capacitors limits their usefulness at high frequencies, however, so we must be careful as to what kind of caps we use. For our high frequency AC-coupling purposes, we will use the largest silver-mica cap value available in the lab (1000pF). See Chapter 6, Section 6.5.3-6.5.4, of Radmanesh and the 'Capacitors Demystified' handout for more on this.
4. **HSPICE DC Analysis:** Plug in your amplifier values into the LNA spice deck provided on the website and run HSPICE. (See 'HSPICE Info' on the website for a SPICE tutorial and quick reference sheet). Is the amplifier biased correctly (currents and voltages)? What is the power consumption of your circuit? Check the output file for information on DC operating points.
5. **HSPICE AC Analysis:** Simulate and obtain an AC analysis for your design. Plot the S_{11} and S_{22} magnitude and phase in Mwaves and save these for comparison to your results in lab. How good is your match? Can you calculate the input and output impedances at 24.3MHz? Also look at S_{21} . Is the gain what you expect?
6. **Input Signal Levels:** What is the (voltage) amplitude in V at the input of this circuit for a -95dBm input power? By the end of the quarter, your receiver will be able to detect a signal of this magnitude.
7. **Power Gain:** Compute the power gain for your amplifier assuming your simulated input impedance and a 1V source with 50Ω impedance. You can use the load voltage from SPICE at the center frequency of your circuit to calculate the output power. This power gain is known as the 'available power gain', because it is a ratio of the power delivered to the load and the power available from the source. (Note how this is different from the 'operating power gain', calculated earlier in the prelab.) Gain, both voltage and power, is expressed in dB (not dBV or dBm). Can you see why?

5 Multiplier Input Match

The last part of this lab will be to match the output of the LNA (nominally 50Ω) to the input of the multiplier (nominally $1.5k\Omega$). To do this, we will use a familiar looking circuit, pictured at the output of the amplifier in Figure 7. You may use a different matching architecture if you'd like (in fact we'd encourage trying out different ones!), but for simplicity, we have shown here the same tapped inductor tank used on the Colpitts oscillator. Note that you may need additional matching to get a purely real impedance at the input.

1. **Design your Match:** Select values for your impedance match and design it to work around the center frequency of 24.3MHz. Note that you may want to use a tunable capacitor to allow for adjustability. Assume that you have a 50Ω source impedance at the input of the tapped inductor.
2. **Calculate the Q:** What is the Q of this match assuming the amplifier output and multiplier input are purely resistive? How is this situation different from the LC tank of the Colpitts? What is the bandwidth of the match around the center frequency?

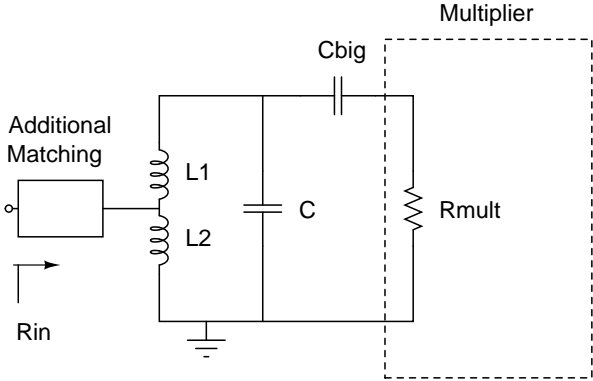

Figure 7: Multiplier Input Match