

Demodulation (either FM or PM)

From demodulation perspective, either FM or PM, its useful to simply think of phase as the natural variable and work with it. The phase locked loop (PLL) is in fact the coolest thing to use:

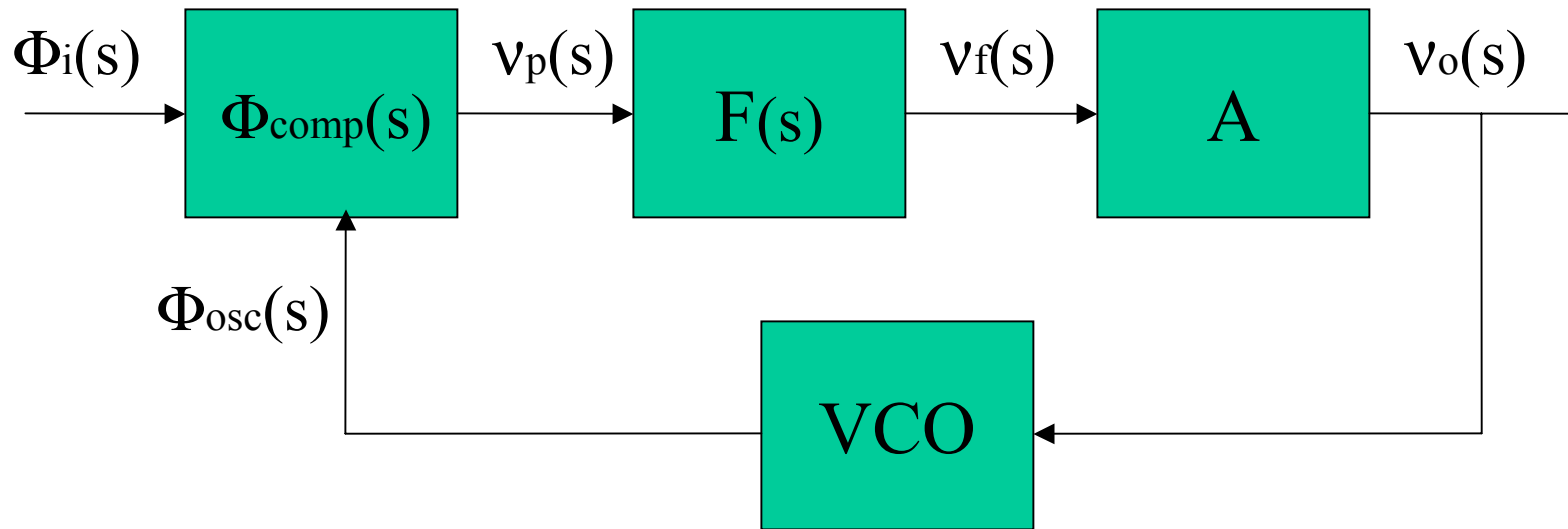

Attached handout (Mayaram & Pederson, Kluwer) gives an excellent small - signal analysis with all the trimmings (SPICE included). Here's a quick summary, as per above block diagram, and analogy to usual feedback formulations:

$$v_o(s) = AF(s) \underbrace{K_p (\phi_i(s) - \phi_{osc}(s))}_{[\phi_{comp}]}$$

note that $\phi_{osc}(s) = \frac{K_o}{s} v_o(s)$

(recall argument from FM handout/discussion)

$$\therefore v_o(s) = AF(s) K_p \left(\phi_i(s) - \frac{K_o}{s} v_o(s) \right)$$

Regrouping terms:

$$\frac{v_o(s)}{\phi_i(s)} = \frac{AF(s)K_p}{1 + \frac{AF(s)K_p K_o}{s}} \quad (*)$$

Again, reviewing FM discussion

$$\begin{aligned} \Delta\omega_i(s) &= \frac{d\phi_i}{dt} = s\phi_i(s) \\ \frac{v_o(s)}{\Delta\omega_i(s)} &= \frac{\frac{dt}{v_o(s)}}{s\phi_i(s)} = \frac{AF(s)K_p}{s + \underbrace{(K_p F(s)AK_o)}_{KL}} \quad (**)$$

Both (*) & (**) are useful:

(*) looks like $\frac{a_f}{1 - a_f f}$

$$-a_f f = \frac{K_L}{s}; \quad K_L = K_p F(s) A K_o$$

(**) looks like transfer function

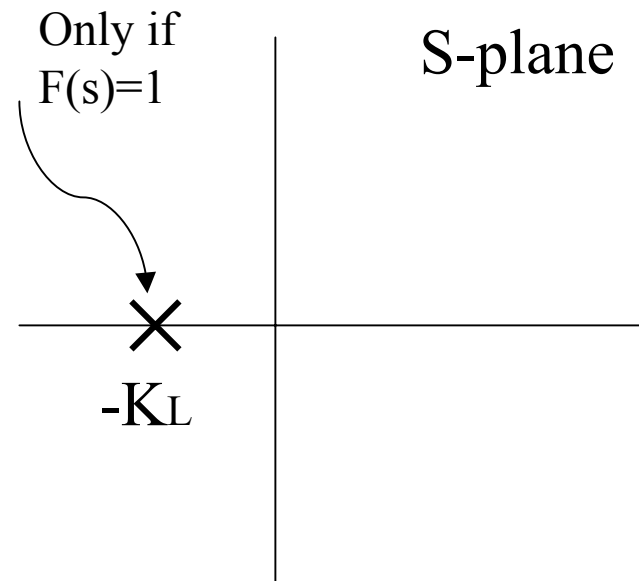
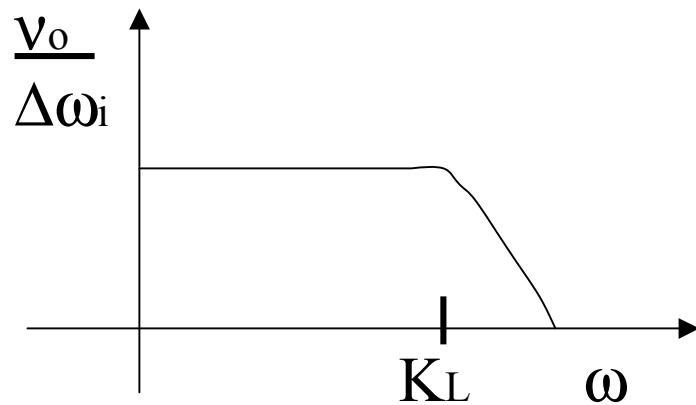

Now "the fun begins" when $F(s) \neq 1$ and poles move w/ feedback (see Mayaram!)

The Phase Comparator (key component!)

Assume that $v_i(t)$ is exactly at the same frequency as $v_{osc}(t)$ but has the phase relationship shown below:

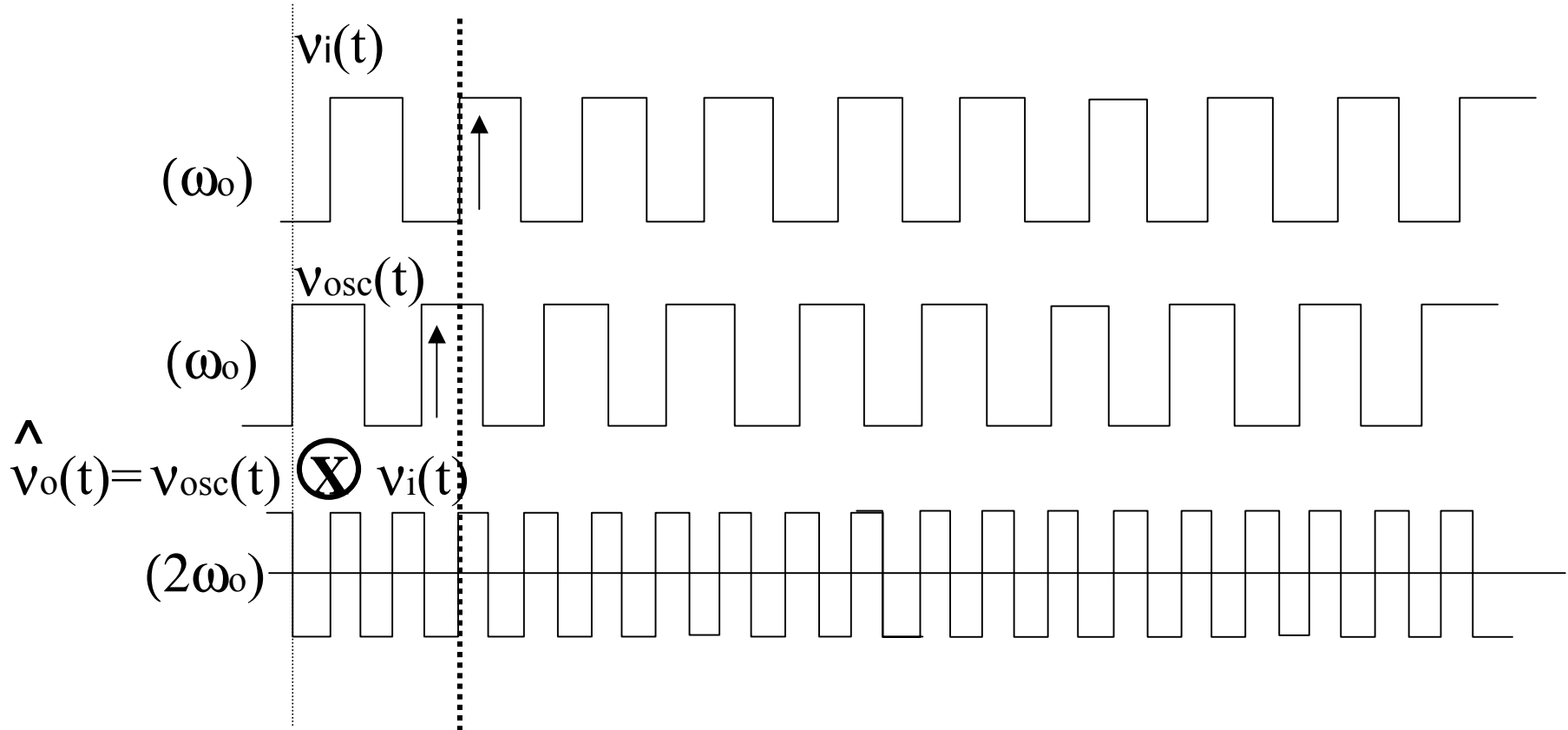

Comments: phase difference between two signals is 90-degrees and for identical frequencies (input and oscillator) then the product will give equal numbers of + and - output voltage segments. That is, in this “locked” condition, the oscillator is working with phase detector and happy that input voltage to VCO is the right one (both frequency and phase are correct)

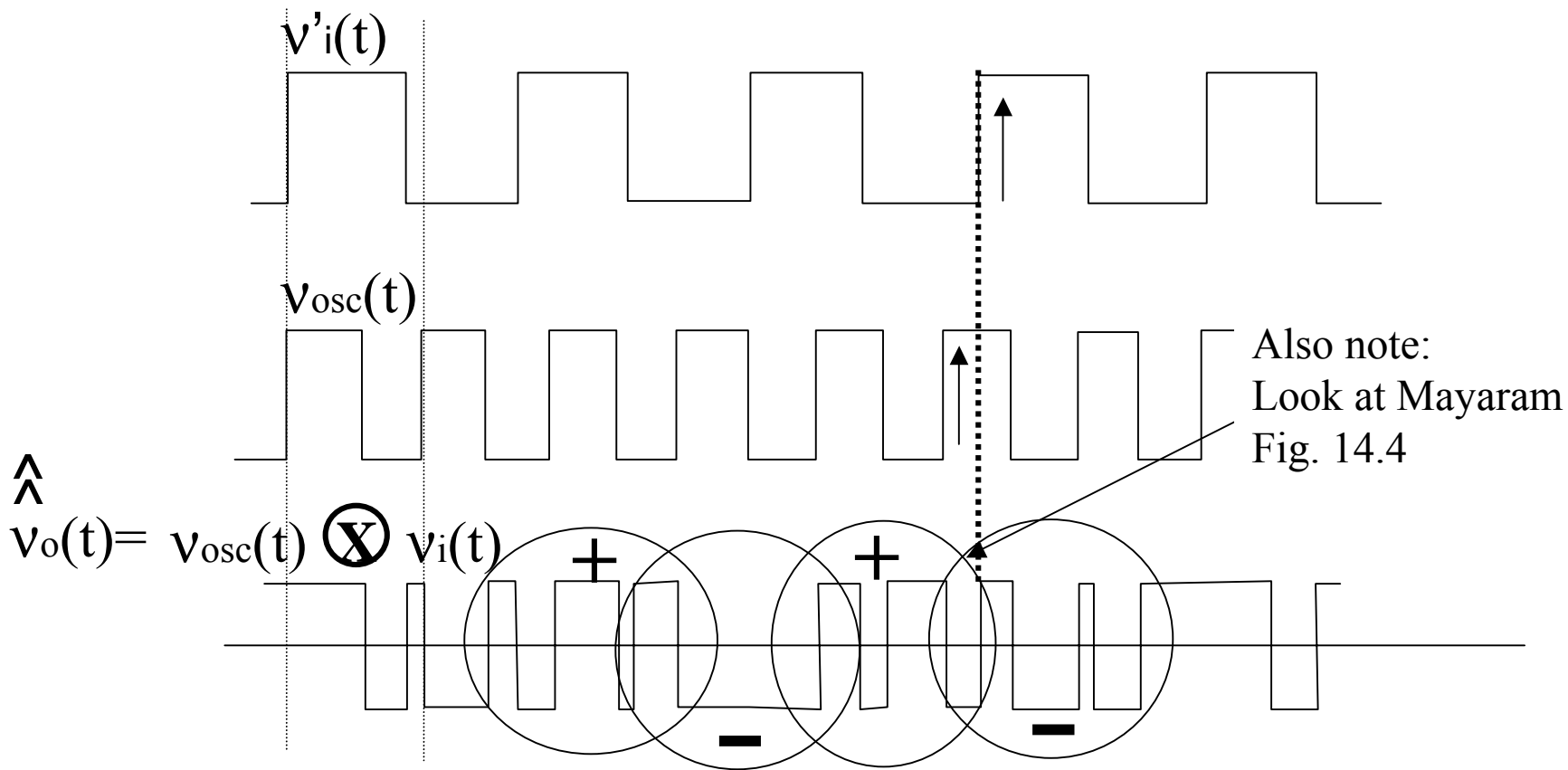

Comments: In this case the frequency of v_i is lower than v_{osc} and the phase between the two inputs is also not close to the 90-degree condition. The result is such that the phase detector (multiplier) output, by trial-and-error, seeks to find the right combination. It tries a + voltage (which should give higher freq. At VCO) and then due to phase error it tries a - voltage (which would then lower the VCO frequency).

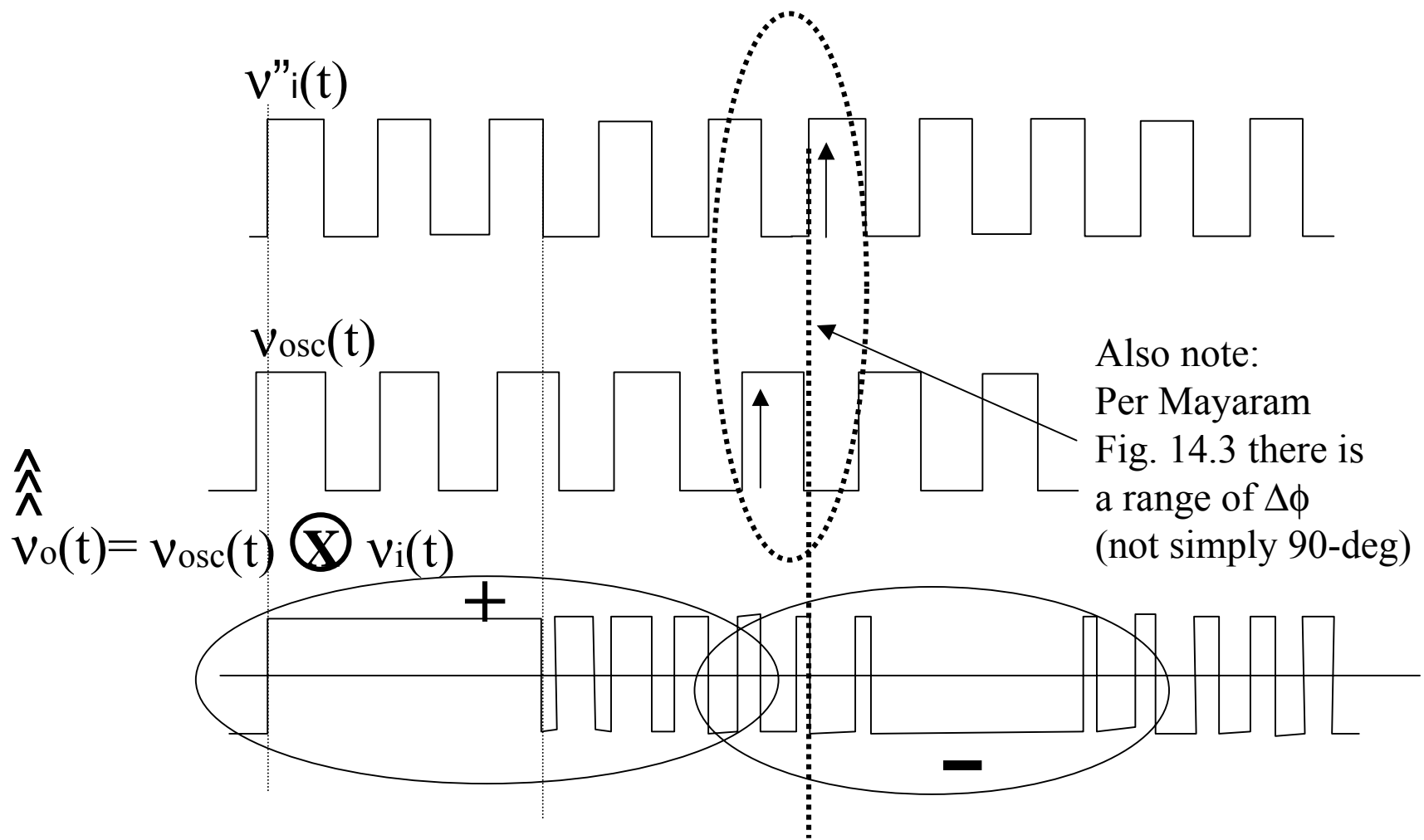

Comments: For this case the input v_i is at a higher frequency (than the VCO) and there are portions that show similar trends to that discussed in the previous slide. Note that at the “cross-over” between + and -, the phase between v_i and v_{osc} tends to be closer to the original 90-degree condition...per Mayaram & Pederson, the phase condition can be either +/- from exactly 90-degrees.

Now, what's $\hat{v}_o(t)$ (also \hat{v}_o al $\hat{\hat{v}}_o$) do to VCO?

$\bar{\hat{v}}_o > 0$ means VCO goes faster

(i.e. it trys to catch frequency of $v_i''(t)$)

$\bar{\hat{v}}_o < 0$ means VCO goes slower

(i.e. $v_i'(t)$ is clearly slower and VCO wants to get there)

Tamara Ahrens Analogy to O/A

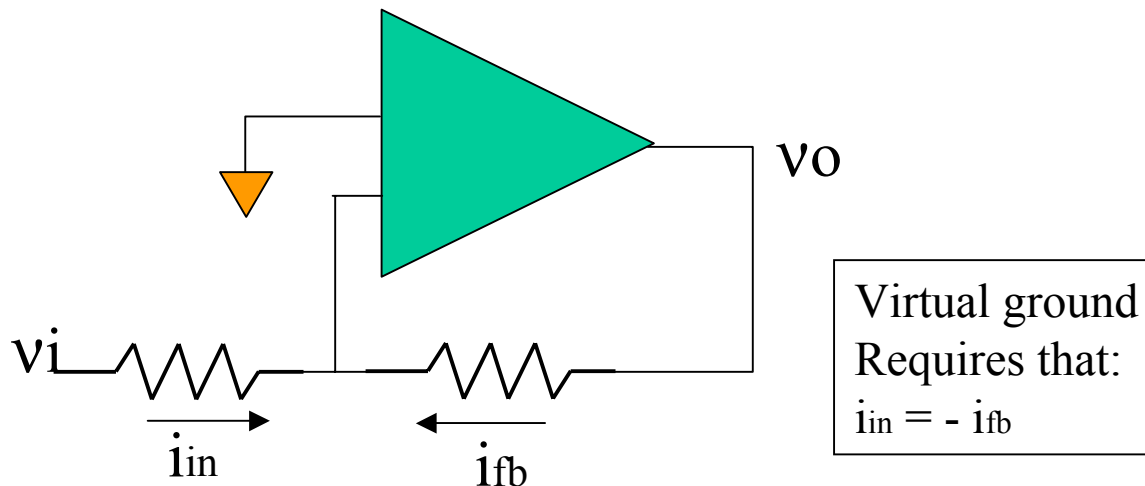

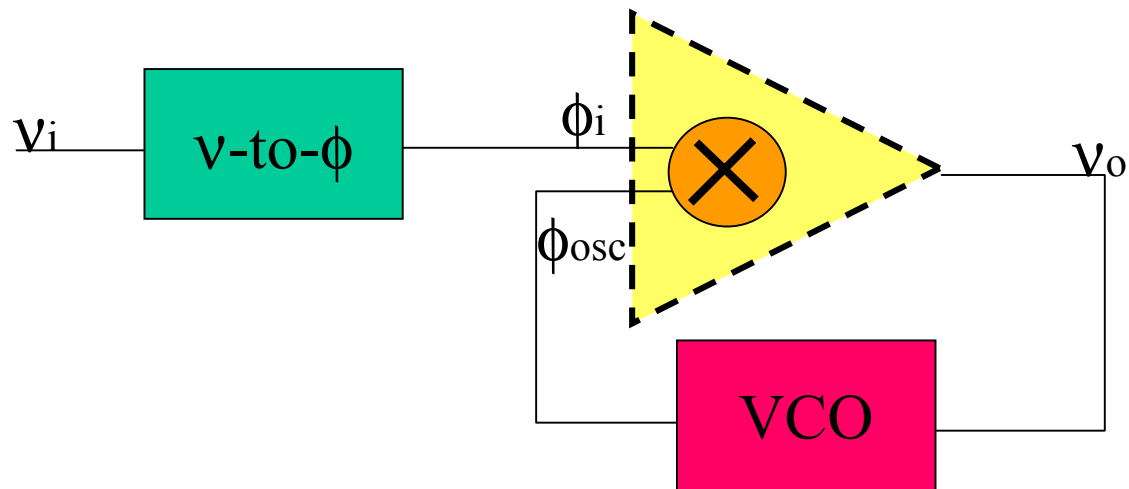

Nodal equation gives :

$$\phi_i + 90^\circ = \phi_{osc} \quad (\text{and same } \omega\text{'s})$$