

EE152 Final Project

1kW Class "D" Amplifier

Ben Stabler
Max Praglin

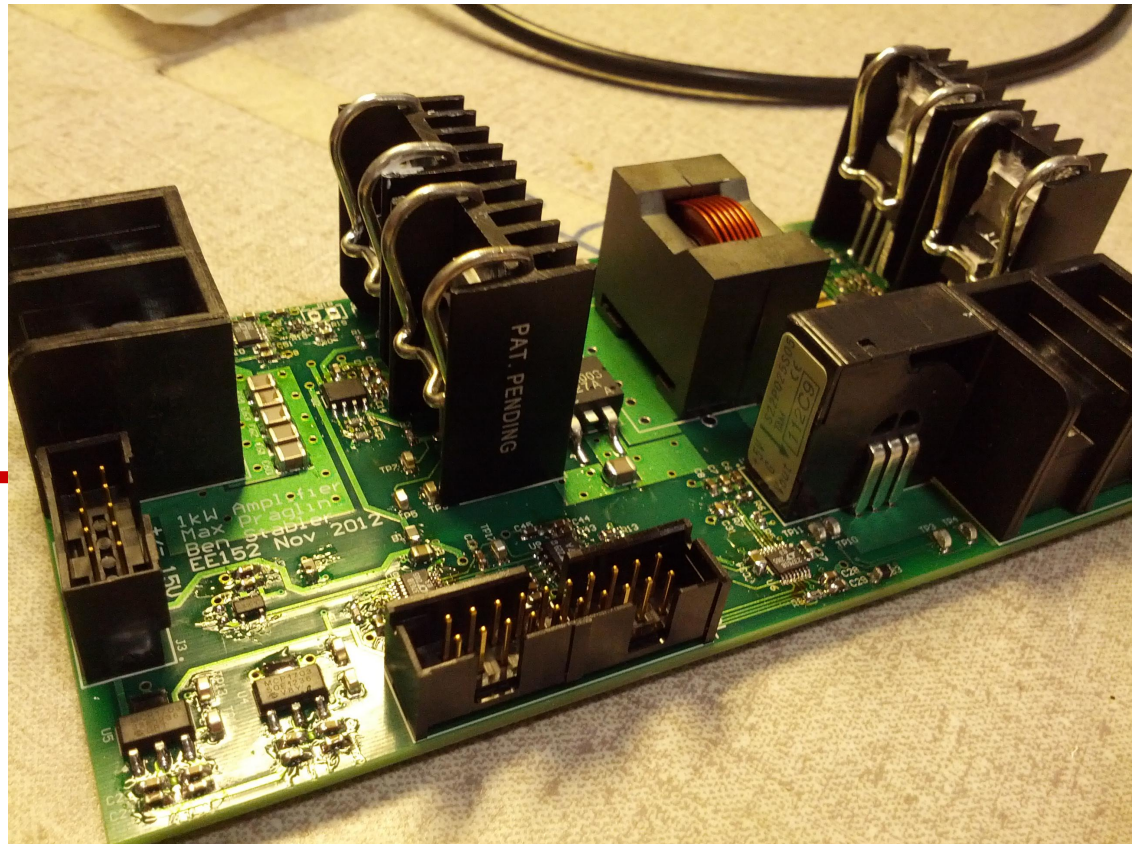

Our Plan

- 1 kW / channel
- Control + Powerstage

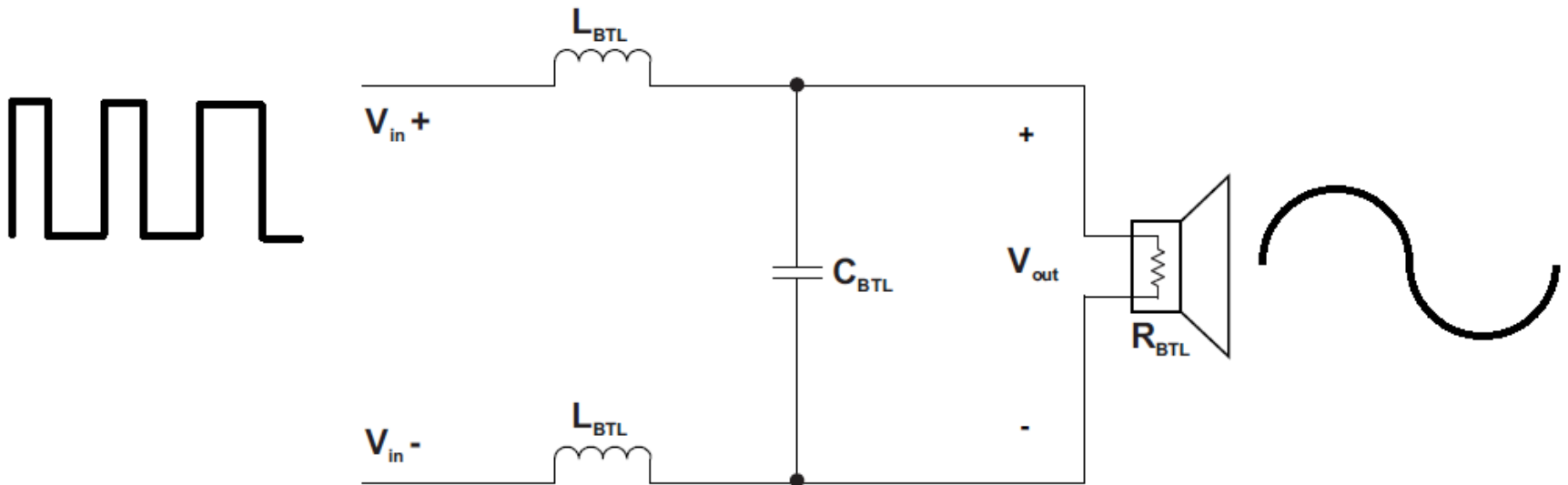

Execution

Simulation

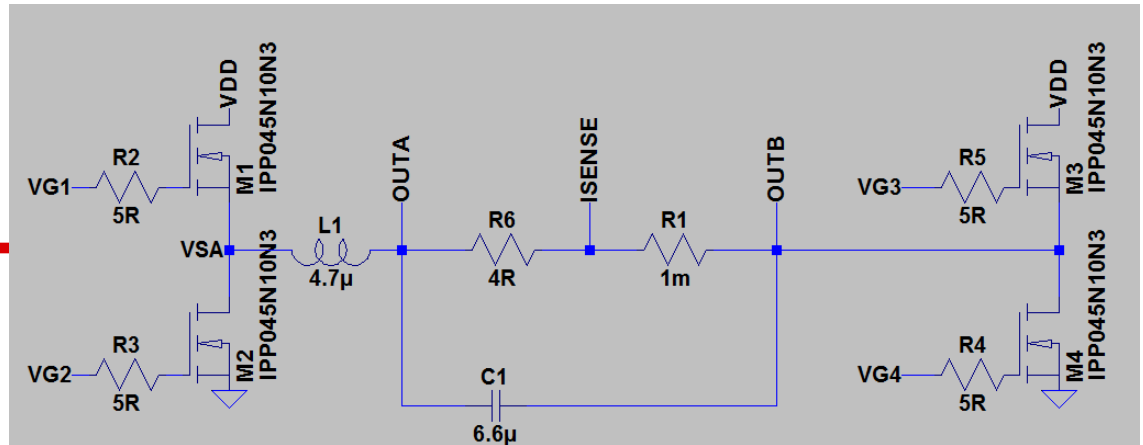

Schematic / Part Selection

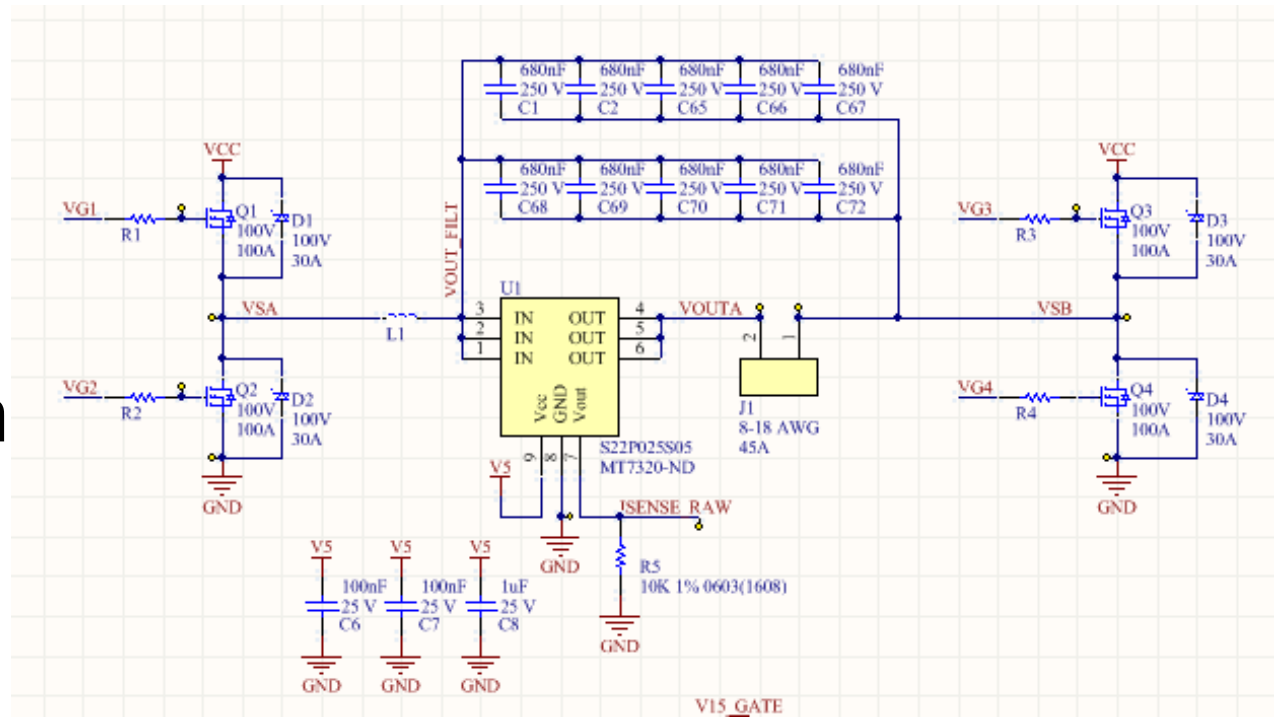

Live Demo

Brace yourselves for...

UNLIMITED* SOUND

*Limited by our power supply

Issues & Mitigation

- Filter
 - Control Law
- Speed
 - FPGA
- Gate Drivers
 - Isolation
- Power Supply

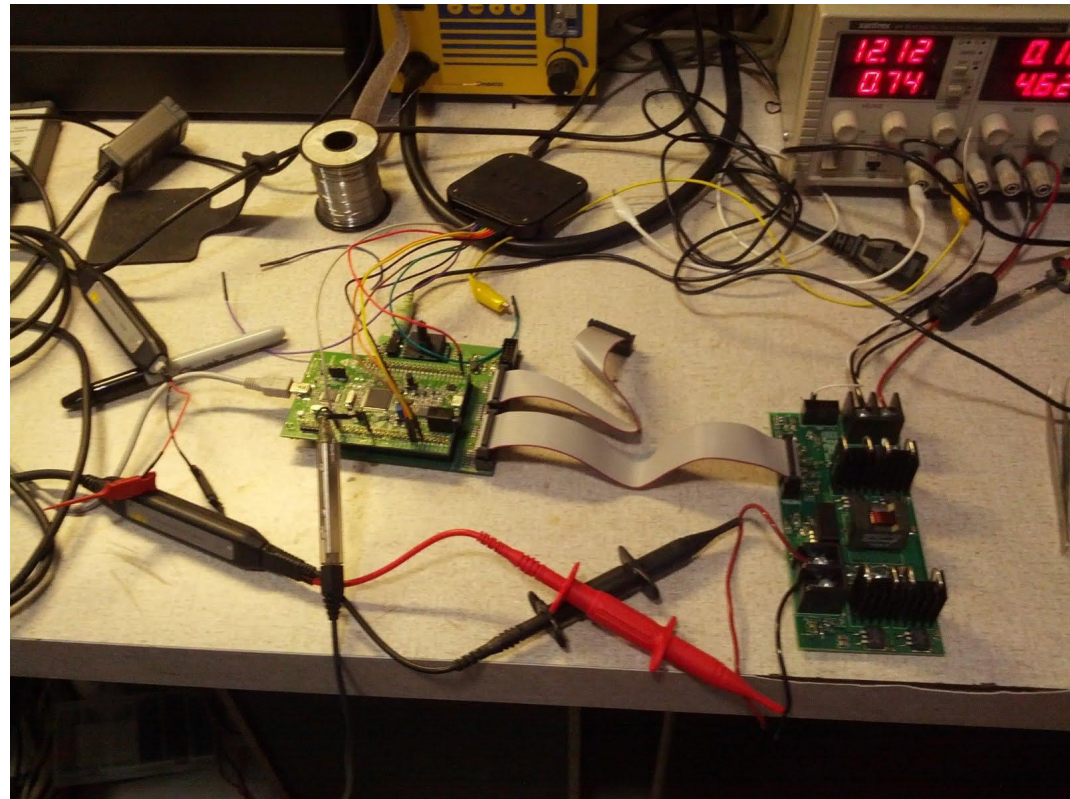

Questions?
