

ME111
 Instructor: Peter Pinsky
 Class #16
 November 1, 2000

Today's Topics

- Introduction to linear elastic fracture mechanics (LEFM).
- State of stress near a crack tip.
- The stress intensity factor and fracture toughness
- Factor of safety for fracture

Reading Assignment

Juvinall 6.1 – 6.4

Problem Set #6 Due in class 11/8/00.

Juvinall 6.2, 6.7

Problems continued on next pages

11/8/00

ME111 Lecture 16

1

Problem 3

A center-cracked plate of AISI 1144 steel ($K_C = 115 \text{ MPa}\sqrt{\text{m}}$) has dimensions $b = 40 \text{ mm}$, $t = 15 \text{ mm}$ and $h = 20 \text{ mm}$. For a factor of safety of three against crack growth, what is the maximum permissible load on the plate if the crack half-length a is: (a) 10 mm, and (b) 24 mm?

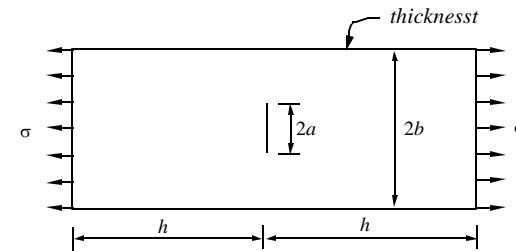

Problem 4

A rectangular beam made of ABS plastic ($K_C = 3 \text{ MPa}\sqrt{\text{m}}$) has dimensions $b = 20 \text{ mm}$ deep and $t = 10 \text{ mm}$ thick. Loads on the beam cause a bending moment of 10 N.m. What is the largest through thickness edge crack that can be permitted if a factor of safety of 2.5 against fracture is required?

11/8/00

ME111 Lecture 16

2

Problem 5

A 50 mm diameter shaft has a circumferential surface crack as shown below, with crack depth $a = 5 \text{ mm}$. The shaft is made of 18-Ni maraging steel ($K_C = 123 \text{ MPa}\sqrt{\text{m}}$).

- (a) If the shaft is loaded with a bending moment of 1.5 kN.m, what is the factor of safety against crack propagation?
- (b) If an axial tensile load of 120 kN is combined with the above bending moment, what is the factor of safety now?

Note: The stress intensity factor for a case of "combined" loading is found by simply summing the stress intensity factors found by considering each loading case separately. This "superposition" works because we are combining linear elastic solutions.

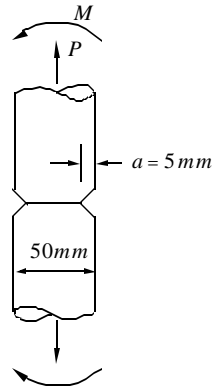

11/8/00

ME111 Lecture 16

3

Problem 6

Two plates of A533B-1 steel are placed together and then welded from one side, with the weld penetrating halfway, as shown below. A uniform tension stress is applied during service. Determine the strength of this joint, as a percentage of its strength if the joint were solid, as limited by (i) fracture, taking into account plasticity at the crack tip, and (ii) fully plastic yielding, for:

- (a) A service temperature of -75°C when the properties are:

$$S_y = 550 \text{ MPa}, \quad K_C = 55 \text{ MPa}\sqrt{\text{m}}$$

- (b) A service temperature of 200°C when the properties are:

$$S_y = 400 \text{ MPa}, \quad K_C = 200 \text{ MPa}\sqrt{\text{m}}$$

- (c) Comment on the suitability of this steel for use at these temperatures.

Notes:

1. Fracture toughness generally increases with temperature while yield strength diminishes.
2. Assume the weld metal has the same properties as the plates.

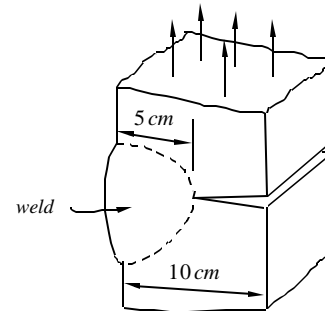

11/8/00

ME111 Lecture 16

4

16.1 What is Fracture Mechanics?

- Structures will frequently have sizeable existing cracks which might or might not grow, depending on the load level.
- To predict failure by crack growth we need a "crack meter," which is provided by fracture mechanics
- When a material has an EXISTING crack, flaw, inclusion or defect of unknown small radius, the stress concentration factor approaches infinity, making it practically useless for predicting stress.

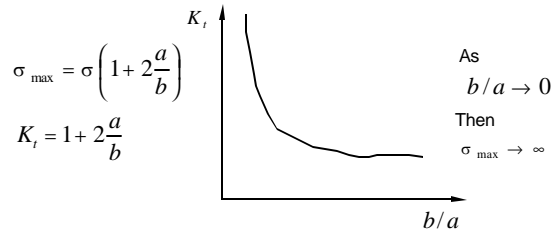
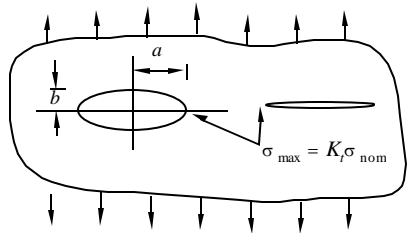

11/8/00

ME111 Lecture 16

5

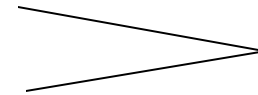

Infinite stresses are predicted by Elasticity theory

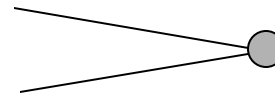

Material will yield and stress remain finite

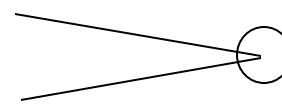

$$\sigma_{\max} = \sigma \left(1 + 2 \frac{a}{a} \right) = 3\sigma$$

$$K_t = 3$$

Drill hole at crack tip – reduces stress concentration and arrests crack growth (e.g. skin of airplane wing)

11/8/00

ME111 Lecture 16

6

- Linear elastic fracture mechanics (LEFM) analyzes the gross elastic changes in a component that occur as a sharp crack grows and compares this to the energy required to produce new fracture surfaces.
- Using this approach, it is possible to calculate the average stress which will cause growth of an existing crack.

16.2 Fracture Conditions

There exist three possible fracture modes, as shown below:

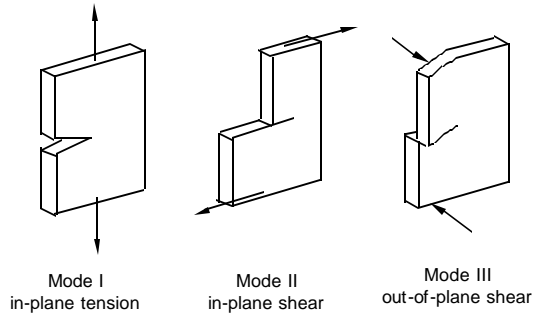

- Mode I is most important (will not consider the others here)

16.3 Stress State Near the Crack Tip

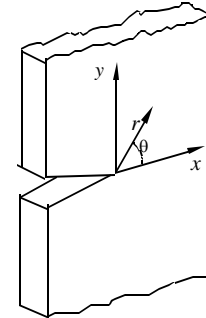

Mode I
in-plane tension

- For Mode I fracture, the stress components at the crack tip are:

$$\left. \begin{aligned} \sigma_x &= \frac{K}{\sqrt{2\pi r}} \cos \frac{\theta}{2} \left[1 - \sin \frac{\theta}{2} \sin \frac{3\theta}{2} \right] + O(r^{1/2}) \\ \sigma_y &= \frac{K}{\sqrt{2\pi r}} \cos \frac{\theta}{2} \left[1 + \sin \frac{\theta}{2} \sin \frac{3\theta}{2} \right] + O(r^{1/2}) \\ \tau_{xy} &= \frac{K}{\sqrt{2\pi r}} \sin \frac{\theta}{2} \cos \frac{\theta}{2} \cos \frac{3\theta}{2} + O(r^{1/2}) \end{aligned} \right\} K = \beta \sigma \sqrt{\pi a}$$

- A crack generates its own stress field, which differs from any other crack tip stress field only by the scaling factor K , which we call the stress intensity factor.

16.4 State of Stress Near a Crack Tip

- Consider a crack in a plate as shown:

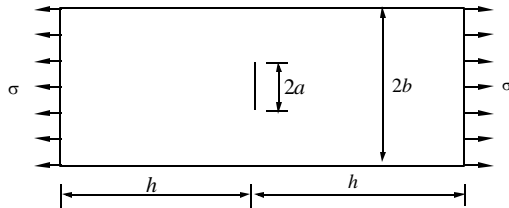

- If $\frac{h}{b} \gg 1, \frac{b}{a} \gg 1$

elastic analysis shows that the conditions for crack growth are controlled by the magnitude of the elastic stress stress intensity factor K_0

$$K_0 = \sigma \sqrt{\pi a}$$

- If the plate has finite dimensions relative to the crack length a , then the value of K_0 must be modified:

$$K = \beta K_0 = \beta \sigma \sqrt{\pi a}$$

where β depends on the geometry of the component and crack.

$K_0 = \sigma \sqrt{\pi a}$ is the base value of the stress intensity factor
 $K = \beta K_0$ is the true stress intensity factor

- The units of the stress intensity factor K are, for example,

$$MPa \sqrt{m}, \text{ or } psi \sqrt{in}, \text{ etc.}$$

- Values of $\beta = K/K_0$ have been determined from the theory of elasticity for many cases of practical importance and some representative cases are plotted in the next few pages (taken from "Mechanical Engineering Design," by Shigley and Mischke).

16.5 Fracture Toughness

- The stress intensity factor K describes the state of stress near a crack tip.
- It is found experimentally that existing cracks will propagate (I.e. grow) when the stress intensity factor K reaches a critical value called the fracture toughness.

- The fracture toughness K_C is a material property that can be measured and tabulated
- The fracture toughness is denoted K_C
- Plane strain conditions are the most conservative

- We have failure by fracture when K grows to $K = K_C$

$K < K_C$ Crack will not propagate

$K \geq K_C$ Crack will propagate

16.6 Factor of Safety in Fracture

$$N = \frac{K_C}{K}$$

16.7 Summary of LEFM

- Elastic analysis, based on the assumption of elastic behavior at the crack tip (i.e. no large-scale plastic deformations occur), shows that the conditions for crack propagation are controlled by the magnitude of the elastic stress intensity factor K

$$K = \beta K_0 = \beta \sigma \sqrt{\pi a}$$

where β depends on the geometry of the component and crack.

-
- It has been found experimentally that a pre-existing crack will propagate when the stress intensity factor reaches a critical value called the fracture toughness K_C

$$K < K_C \quad \text{Crack will not propagate}$$

$$K \geq K_C \quad \text{Crack will propagate}$$

-
- The factor of safety for a given stress intensity factor is:

$$N = \frac{K_C}{K}$$

16.8 Values of K_C for Some Metals

Material	$K_C, MPa\sqrt{m}$	S_y, MPa
Aluminum		
2024	26	455
7075	24	495
7176	33	490
Titanium		
Ti-6AL-4V	115	910
Ti-6AL-4V	55	1035
Steel		
4340	99	860
4340	60	1515
52100	14	2070

Example 16.1

A steel ship deck is 30 mm thick, 12 m wide and 20 m long and has a fracture toughness of $K_C = 28.3 \text{ MPa}\cdot\text{m}^{1/2}$. If a 65 mm long central transverse crack is discovered, calculate the nominal tensile stress that will cause catastrophic failure. Compare the stress found to the yield strength of $S_y = 240 \text{ MPa}$.

- First compute the stress intensity factor:

$$a/b = \frac{325}{6000} = 0.005 \quad h/b = \frac{10}{6} = 1.67$$

From, Fig. 5-19, we find $\beta = \frac{K}{K_0} \approx 1$ (essentially an infinite plate)

$$K = \beta \sigma \sqrt{\pi a} = (1.0)(\sigma)(\sqrt{\pi(32.5 \times 10^{-3})})$$

For failure we have:

$$K = K_C \Rightarrow (1.0)(\sigma)(\sqrt{\pi(32.5 \times 10^{-3})}) = 28.3$$

$$\sigma = \frac{28.3}{\sqrt{\pi(32.5 \times 10^{-3})}} = 88.6 \text{ MPa}$$

The uniaxial stress that will cause yielding is given by $S_y = 240 \text{ MPa}$

We note that $\frac{S_y}{\sigma} = \frac{240}{88.6} = 2.71$ (fracture occurs well before yielding)

Example 16.2

A plate of width 1.4 m and length 2.8 m is required to support a tensile load of 4 MN (in the long direction). Inspection procedures are capable of detecting through-thickness edge cracks larger than 2.7 mm. The two titanium alloys in the table on page are being considered for this application. For a factor of safety of $N = 1.3$ against yielding and fracture, which one of the two alloys will give the lightest weight solution?

- We start by determining thickness based on yielding:

$$N = \frac{S_y}{\sigma} = \frac{S_y}{P/wt} \Rightarrow t = \frac{PN}{wS_y}$$

For the weaker alloy (call it alloy A)

$$t = \frac{PN}{wS_y} = \frac{(4 \times 10^6)(1.3)}{(1,400)(910)} = 4.08 \text{ mm} \quad \sigma = \frac{S_y}{N} = \frac{910}{1.3} = 700 \text{ MPa}$$

For the stronger alloy (call it alloy B)

$$t = \frac{PN}{wS_y} = \frac{(4 \times 10^6)(1.3)}{(1,400)(1035)} = 3.59 \text{ mm} \quad \sigma = \frac{S_y}{N} = \frac{1035}{1.3} = 796 \text{ MPa}$$

- We now find the thickness to prevent crack growth (see Fig. 5-22):

$$\frac{h}{b} = \frac{2.8/2}{1.4} = 1, \quad \frac{a}{b} = \frac{2.7}{1,400} = 0.00193 \Rightarrow \beta = \frac{K}{K_0} = 1.1$$

$$K = \beta K_0 = \beta \sigma \sqrt{\pi a} = (1.1)\sigma \sqrt{\pi(2.7 \times 10^{-3})} = 0.1013 \sigma$$

We also have, $N = \frac{K_C}{K}$ so that,

$$K = 0.1013 \sigma = \frac{K_C}{N} \Rightarrow \sigma = \frac{K_C}{0.1013 N}$$

For the weaker alloy (alloy A)

$$\sigma = \frac{K_C}{0.1013N} = \frac{115}{(0.1013)(1.3)} = 873.3 \text{ MPa}$$

$$t = \frac{P}{w\sigma} = \frac{4 \times 10^6}{(1,400)(873.3)} = 3.27 \text{ mm}$$

For the stronger alloy (alloy B)

$$\sigma = \frac{K_C}{0.1013N} = \frac{55}{(0.1013)(1.3)} = 417.6 \text{ MPa}$$

$$t = \frac{P}{w\sigma} = \frac{4 \times 10^6}{(1,400)(417.6)} = 6.84 \text{ mm}$$

Summary:

Weak alloy (A):

Yielding	$t = 4.08 \text{ mm}$	$\sigma = 700 \text{ MPa}$
Fracture	$t = 3.27 \text{ mm}$	$\sigma = 873.3 \text{ MPa}$

Strong alloy (B):

Yielding	$t = 3.59 \text{ mm}$	$\sigma = 796 \text{ MPa}$
Fracture	$t = 6.84 \text{ mm}$	$\sigma = 418 \text{ MPa}$

Fracture toughness limits design

Best design solution: use weak alloy (A) with $t = 4.08 \text{ mm}$ governed by yielding

11/8/00 ME111 Lecture 16 15

Example 16.3

A long rectangular plate has a width of 100 mm, thickness of 5 mm and an axial load of 50 kN. If the plate is made of aluminum 2014-T651, ($K_C = 24 \text{ MPa}\sqrt{m}$) what is the critical crack length for failure ($N = 1$)?

At the critical crack length,

$$K_C = K = \beta \sigma \sqrt{\pi a}$$

But β depends on a/b , making a direct calculation of a impossible.

$$24 = \beta \left(\frac{50,000}{(100)(5)} \right) \sqrt{\pi a}$$

or

$$\beta \sqrt{a} = 0.135$$

↑ meters!

Using Fig. 5-21:

$a = 0.04, a/b = 0.8, \beta = 1.85, \beta \sqrt{a} = 0.37$

$a = 0.01, a/b = 0.2, \beta = 1.02, \beta \sqrt{a} = 0.102$

⋮

$a = 0.015, a/b = 0.3, \beta = 1.06, \beta \sqrt{a} = 0.13$

Critical crack length $a = 15 \text{ mm}$.

11/8/00 ME111 Lecture 16 16

Example 16.4

For the proceeding problem, what is the factor of safety against fracture for a crack of length 10 mm which is:

- (a) Centered in the plate
(b) On the edge of the plate

(a) Determine the stress intensity factor from Fig. 5-21:

$$a = 5 \text{ mm}, a/b = 0.1, \beta = 1.02$$

$$K = \beta \sigma \sqrt{\pi a} = (1.02) \left(\frac{50,000}{(100)(5)} \right) \sqrt{0.0 \text{ m}} = 18.1 \text{ MPa}\sqrt{\text{m}}$$

calculate the factor of safety:

$$N = \frac{K_C}{K} = \frac{24}{18.1} = 1.33$$

(b) Determine the stress intensity factor from Fig. 5-22:

$$a = 10 \text{ mm}, a/b = 0.1, \beta = 1.02$$

Which is the same as (a)

$$N = 1.33$$

11/8/00

ME111 Lecture 16

17

16.9 Effects of Small Scale Yielding at the Crack Tip

- Stress are predicted to become infinite near the crack tip according to LEFM.
- For ductile materials, stresses are limited by local yielding in the vicinity of the crack tip.

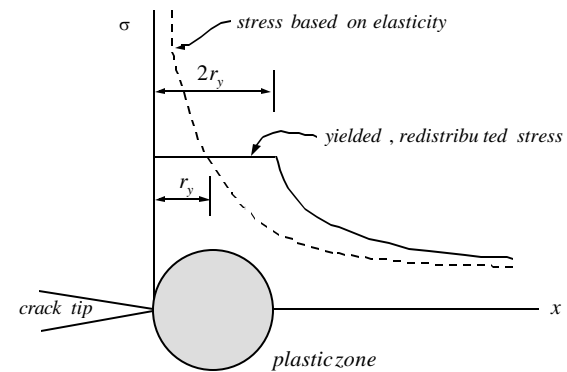

11/8/00

ME111 Lecture 16

18

- The size of the plastic zone can be investigated as follows:

- It may be shown that

$$r_y = \frac{1}{2\pi} \left(\frac{K}{S_y} \right)^2$$

- Stress redistribution accompanies plastic yielding and causes the plastic zone to extend approximately

$$2r_y = \frac{1}{\pi} \left(\frac{K}{S_y} \right)^2$$

ahead of the real crack tip to satisfy equilibrium conditions (see figure on previous page).

11/8/00

ME111 Lecture 16

19

- To account for this, we think of the plastic zone as providing a virtual crack tip extension to a new effective crack size:

$$a_{eff} = a + 2r_y = a + \frac{1}{\pi} \left(\frac{K}{S_y} \right)^2$$

- We observe that:

$$K = \beta \sigma \sqrt{\pi a_{eff}}$$

the use of which now requires an iterative solution because β depends on a_{eff} .

Concluding Remarks:

- In many problems, the plastic zone is very small and can be neglected in determining the stress intensity factor.
- However, when the stress intensity factor approaches the fracture toughness value, the plastic zone correction becomes significant and should be investigated.
- If the plastic zone size becomes "large" relative to the crack size the accuracy of LEFM becomes questionable, and an elastic-plastic fracture mechanics approach should be considered.

11/8/00

ME111 Lecture 16

20

Example 16.5

A long rectangular plate has a width of 100 mm, thickness of 5 mm and an axial load of 50 kN. If the plate is made of titanium Ti-6AL-4V, ($S_y = 910 \text{ MPa}$, $K_C = 115 \text{ MPa}\sqrt{\text{m}}$) what is the factor of safety against crack growth for a crack of length $a = 20 \text{ mm}$.

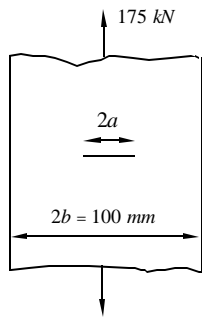

We wish to compute the stress intensity factor so that we can evaluate:

$$N = \frac{K_C}{K}, \quad K = \beta \sigma \sqrt{\pi a_{eff}}$$

Now

$$K^{i+1} = \beta (a_{eff}) \frac{175000}{(100)(5)} \sqrt{\pi} \sqrt{a_{eff}}$$

$$a_{eff} = a + \frac{1}{\pi} \left(\frac{K^i}{S_y} \right)^2$$

Example 16.6

The round bar of aluminum 2024-T851 has a sharp notch around its circumference. Assume:

$$S_y = 455 \text{ MPa}, \quad K_C = 26.4 \text{ MPa}\sqrt{\text{m}}$$

Find:

- (a) The size of the plastic zone at the crack tip.
- (b) The fracture load.

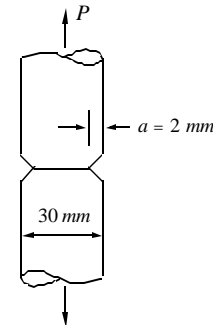

Example 16.7

For the steel beam shown, a crack of length $a = 0.25$ in will be detectable. Find the beam thickness to provide a factor of safety $N = 2$, (a) ignoring the plastic zone at the crack tip, (b) taking the plastic zone into account. Take:

$$S_y = 220 \text{ kpsi}, \quad K_C = 55 \text{ kpsi}\sqrt{\text{in}}$$

