

ME111
Mid-Term Exam
November 6, 2000

90 Minutes, Open Notes and Textbook (Only)

Problem 1 (34 Points)

- (a) Explain very briefly why principal stresses are important.
- (b) If the stress state at a point is given by:

$$\sigma_x = 100 \text{ MPa} \quad \sigma_y = 100 \text{ MPa} \quad \sigma_z = -50 \text{ MPa} \quad \tau_{xy} = -50 \text{ MPa}$$

Draw Mohr's circles for this stress state and determine the following:

- (i) The principal stresses and make a sketch of a properly oriented "stress element" showing the σ_1 and σ_2 principal stresses and the angle of the planes on which they act.
- (ii) The maximum shear stress.
- (c) A cylindrical pressure vessel is subjected to an internal pressure of 20 MPa and an external moment and torque as shown. Determine the state of stress at point A on the outer surface; sketch the stress element and Mohr's circles for this stress state.

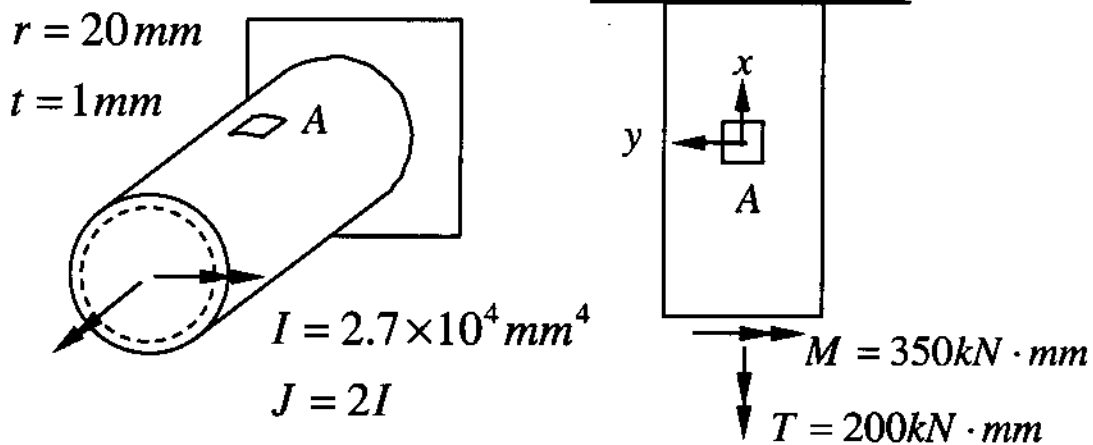

Problem 2 (33 Points)

For the arm assembly shown, the designer must ensure that the vertical deflection at point C does not cause contact with the adjacent surface. Each segment is a circular bar with diameter indicated, and made from aluminum with $E=60\text{GPa}$

- Determine the support reactions at A
- Sketch the bending moment and torque distributions along the three arms.
- Using Castigliano's theorem, determine the vertical deflection of point C and establish whether contact will occur.

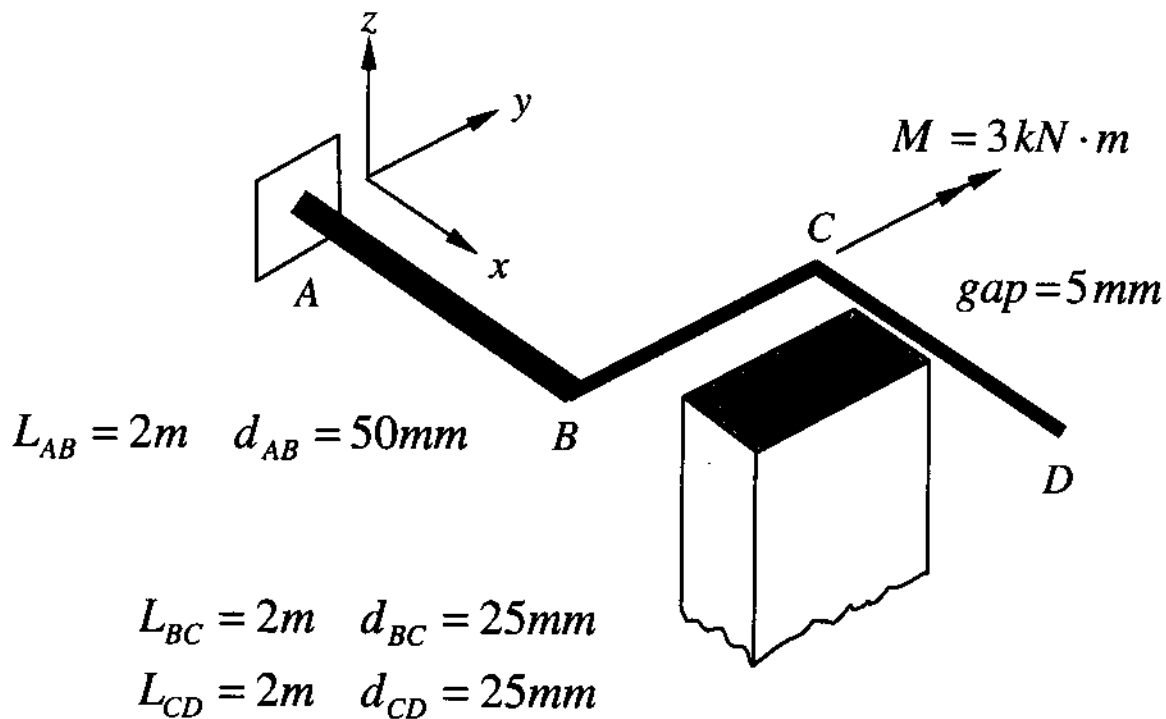

Problem 3 (25 Points)

For the truss shown, determine the factor of safety against buckling for a load of 125 kN. Both truss members have the same dimensions and properties. Assume that they are pinned at their ends in both directions.

Both truss members:

$$L = 600 \text{ mm}$$

$$E = 200 \text{ GPa}$$

$$S_y = 400 \text{ MPa}$$

Rectangular cross-section

$$25 \times 40 \text{ mm}$$

