

2. MODELING A MIXING ELBOW (2-D)

In this tutorial, you will use GAMBIT to create the geometry for a mixing elbow and then generate a mesh. The mixing elbow configuration is encountered in piping systems in power plants and process industries. It is often important to predict the flow field and temperature field in the neighborhood of the mixing region in order to properly design the location of inlet pipes.

In this tutorial you will learn how to:

- Create vertices using a grid system
- Create arcs by selecting the center of curvature and the endpoints of the arc
- Create straight edges between vertices
- Split an arc using a vertex point
- Create faces from edges
- Specify the distribution of nodes on an edge
- Create structured meshes on faces
- Set boundary types
- Prepare the mesh to be read into FLUENT 4
- Export a mesh

2.1 Prerequisites

This tutorial assumes that you have worked through Tutorial 1 and you are consequently familiar with the GAMBIT interface.

2.2 Problem Description

The problem to be considered is shown schematically in Figure 2-1. A cold fluid enters through the large pipe and a warmer fluid enters through the small pipe. The two fluids mix in the elbow.

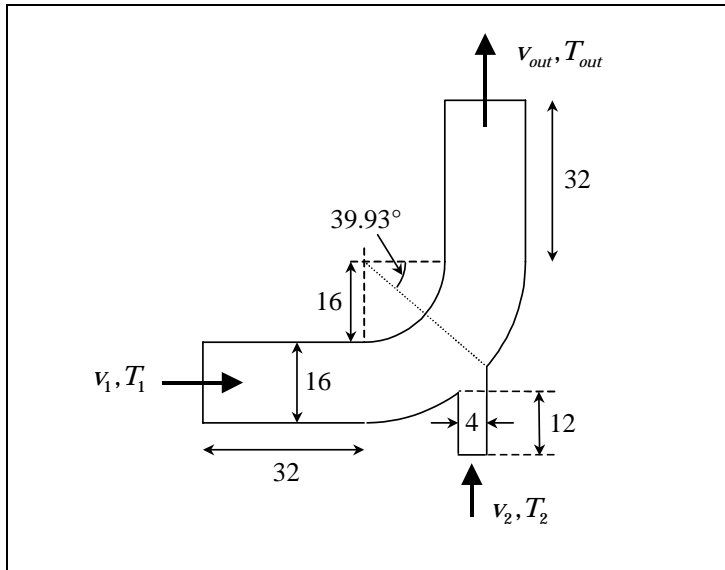

Figure 2-1: Problem specification

2.3 Strategy

In this tutorial, you will build a 2-D mesh using a “bottom-up” approach (in contrast to the “top-down” approach used in Tutorial 1). The “bottom-up” approach means that you will first create some vertices, connect the vertices to create edges, and connect the edges to make faces (in 3-D, you would stitch the faces together to create volumes). While this process by its very nature requires more steps, the result is, just as in Tutorial 1, a valid geometry that can be used to generate the mesh.

The mesh created in this tutorial is intended for use in FLUENT 4, so it must be a single block, structured mesh. However, this mesh can also be used in any of the other Fluent solvers. This type of mesh is sometimes called a mapped mesh, because each grid point has a unique I, J, K index. In order to meet this criterion, certain additional steps must be performed in GAMBIT and are illustrated in this tutorial. After creating the straight edges and arcs that comprise the geometry, you will create two faces: one for the main flow passage (the elbow) and one for the smaller inlet duct. The mesh is generated for the larger face using the Map scheme; this requires that the number of grid nodes be equal on opposite edges of the face. You will force GAMBIT to use the Map scheme to mesh the smaller face as well.

Several other features are also demonstrated in this tutorial:

- Using a background grid and “snap-to-grid” to quickly create a set of vertices.
- Using “pick lists” as an alternative to mouse clicks for picking entities.
- Specifying a non-uniform distribution of nodes on an edge.
- Setting boundary types.
- Exporting a mesh for a particular Fluent solver (FLUENT 4 in this case).

2.4 Procedure

Start GAMBIT.

Step 1: Select a Solver

1. Choose the solver you will use to run your CFD calculation by selecting the following from the main menu bar:

Solver → FLUENT 4

*This selects the **FLUENT 4** solver as the one to be used for the CFD calculation. The choice of a solver dictates the options available in various forms (for example, the boundary types available in the **Specify Boundary Types** form). The solver currently selected is indicated at the top of the GAMBIT GUI.*

Step 2: Create the Initial Vertices

1. Create vertices to define the outline of the large pipe of the mixing elbow.



*This command sequence opens the **Display Grid** form.*

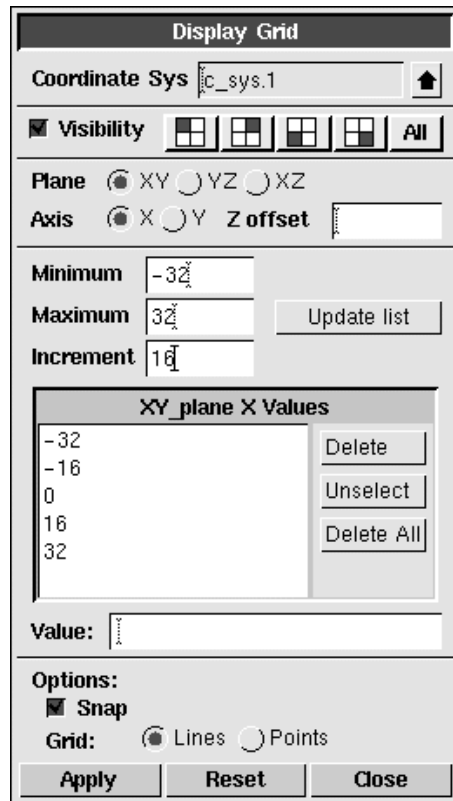

- a) Check that **Visibility** is selected.

This ensures that the background grid will be visible when it is created.

- b) Select X (the default) to the right of **Axis**.
- c) Enter a **Minimum** value of -32, a **Maximum** value of 32, and an **Increment** of 16.
- d) Click the Update list button.

This creates a background grid with four cells in the x direction and enters the x coordinates in the XY_plane X Values list.

- e) Select Y to the right of **Axis**.
- f) Enter a **Minimum** value of -32, a **Maximum** value of 32, and an **Increment** of 16.
- g) Click the Update list button.

This creates a background grid with four cells in the y direction and enters the y coordinates in the XY_plane Y Values list.

- h) Check that **Snap** is selected under **Options**.

The vertices you create later in this step will be “snapped” to points on the grid where the grid lines intersect.

- i) Select Lines (the default) to the right of **Grid**.

The grid will be displayed using lines rather than points.

- j) Click **Apply**.

GAMBIT will draw a 4x4 grid in the graphics window as shown in Figure 2-

2. You will need to click the **FIT TO WINDOW**  command button at the top left of the **Global Control** toolpad to see the whole grid. You may need to move the **Display Grid** form in order to access the **Global Control** toolpad.

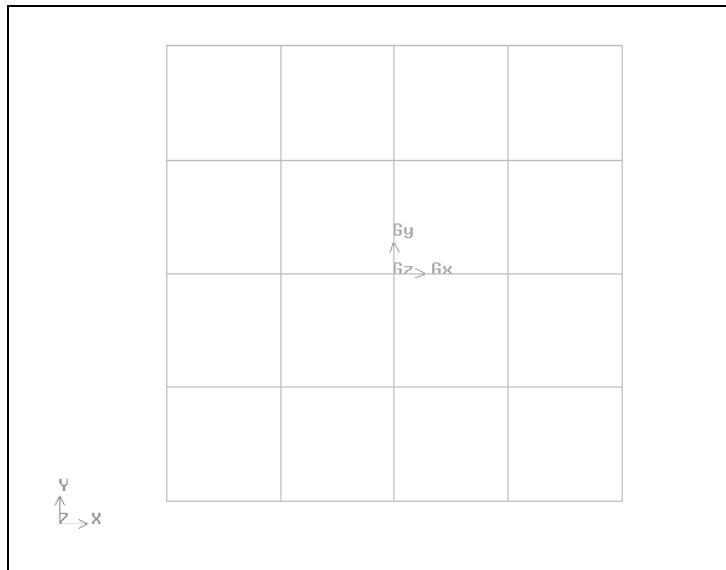



Figure 2-2: 4x4 grid to be used for creating vertices

- k) *Ctrl-right-click* the nine grid points shown in Figure 2-3.

“Ctrl-right-click” indicates that you should hold down the *Ctrl* key on the keyboard and click on the point at which the vertex is to be created using the right mouse button.

You can use the **UNDO** command button  if you create any of the vertices incorrectly.

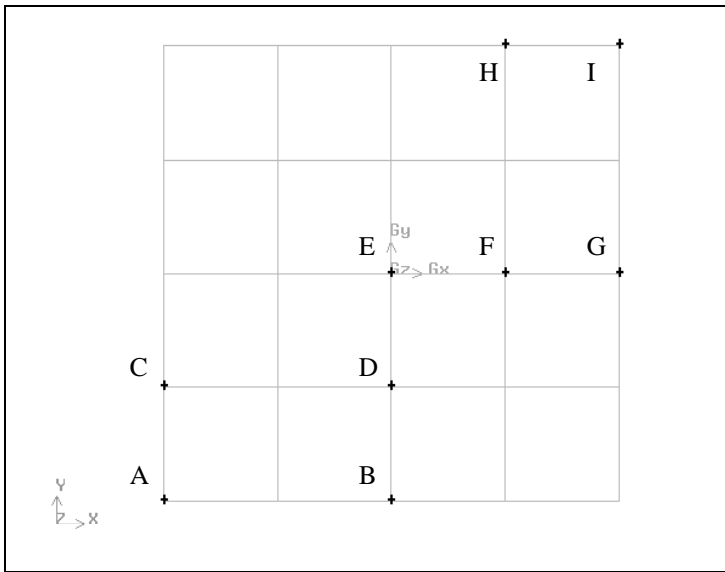

Figure 2-3: Create vertices at grid points

- 1) Unselect the **Visibility** check box in the **Display Grid** form and click **Apply**.

The grid will be removed from the graphics window and you will be able to clearly see the nine vertices created, as shown in Figure 2-4.

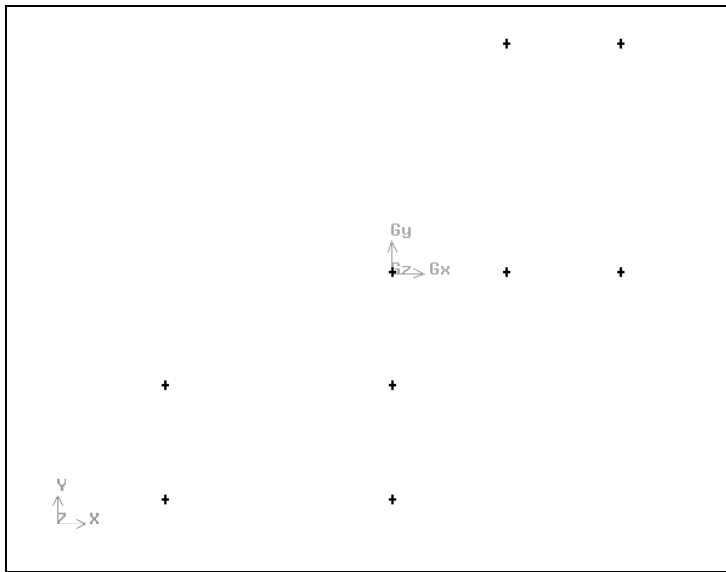
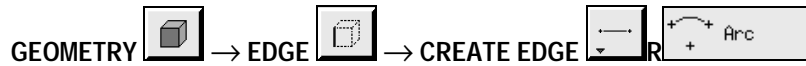

Figure 2-4: Vertices for the main pipe

Step 3: Create Arcs for the Bend of the Mixing Elbow

1. Create an arc by selecting the following command buttons in order:



This command sequence opens the **Create Real Circular Arc** form.

- a) Retain the default **Method**.

*Notice that the **Center** list box is yellow in the **Create Real Circular Arc** form at this point. The yellow color indicates that this is the active field in the form, and any vertex selected will be entered into this box on the form.*

- b) *Shift-left-click* the vertex in the center of the graphics window (vertex E in Figure 2-5).

*The selected vertex will appear red in the graphics window and its name will appear in the **Center** list box under **Vertices** in the form.*

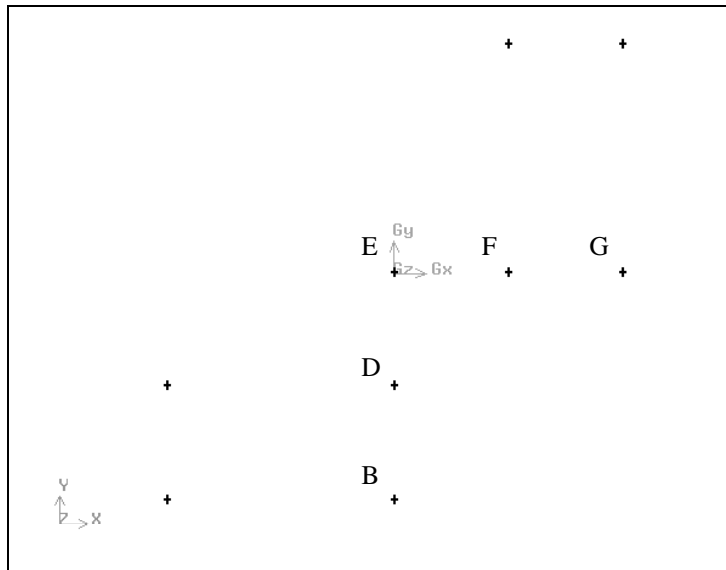

Figure 2-5: Vertices used to create arcs

- c) Left-click in the list box to the right of **End-Points** to accept the selection of vertex E and make the **End-Points** list box active.

! *Alternatively, you could continue to hold down the Shift key and click the right mouse button in the graphics window to accept the selection of the vertex and move the focus to the **End-Points** list box.*

*Note that the **End-Points** list box is now yellow—that is, this is now the active list box, and any vertex selected will be entered in this box.*

- d) *Shift*-left-click the vertex to the right of the center vertex in the graphics window (vertex F in Figure 2-5).

The vertex will turn red.

- e) Select the vertex directly below the one in the center of the graphics window (vertex D in Figure 2-5).
- f) Click **Apply** to accept the selected vertices and create the arc.

2. Repeat the above steps to create a second arc. The center of the arc is the vertex in the center of the graphics window (vertex E in Figure 2-5). The endpoints of the arc are the vertices to the right and below the center vertex that have not yet been selected (vertices G and B, respectively, in Figure 2-5). The arcs are shown in Figure 2-6.

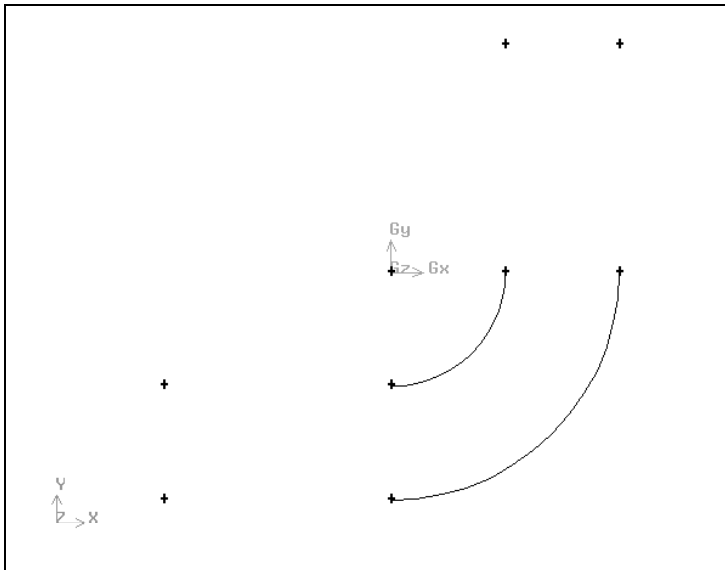
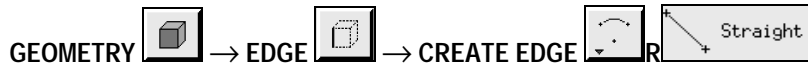

Figure 2-6: Vertices and arcs

Step 4: Create Straight Edges

1. Create straight edges for the large pipe.



This command sequence opens the Create Straight Edge form.

a) *Shift*-left-click the left endpoint of the smaller arc (vertex D in Figure 2-7).

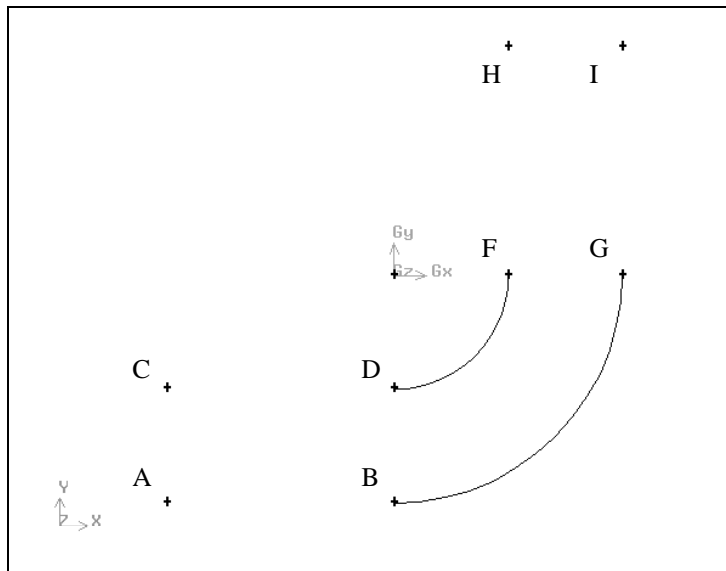

Figure 2-7: Vertices used to create straight edges

b) *Shift*-left-click the vertices marked C, A, and B in Figure 2-7, in order.

- c) Click **Apply** to accept the selection of the vertices.

Three straight edges are drawn between the vertices.

- d) *Shift-left-click* the vertices marked F, H, I, and G in Figure 2-7, in order.
- e) Click **Apply** to accept the selection of the vertices.

The graphics window with the arcs and straight edges is shown in Figure 2-8.

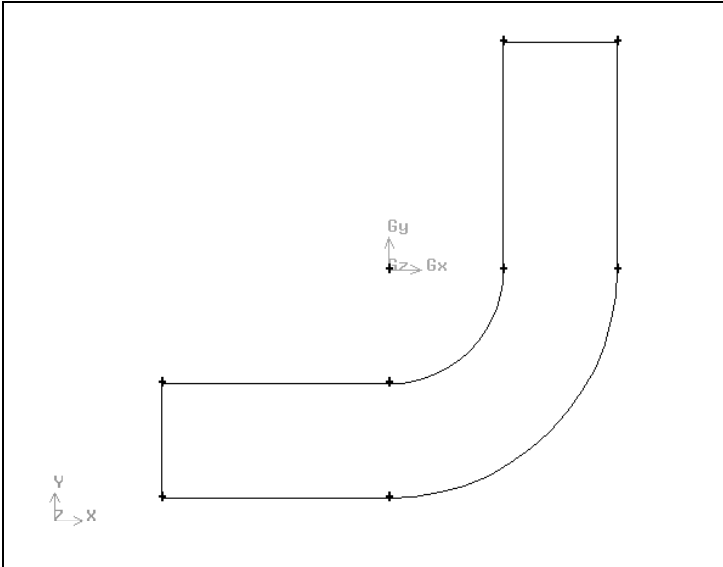

Figure 2-8: Arcs and edges





Step 5: Create the Small Pipe for the Mixing Elbow

In this step, you will create vertices on the outer radius of the bend of the mixing elbow and split the large arc into three smaller arcs. Next, you will create vertices for the inlet of the small pipe. Finally, you will create the straight edges for the small pipe.

1. Create vertices on the outer radius of the bend, and split the large arc into three sections.

GEOMETRY  → EDGE  → SPLIT/MERGE EDGES 

This command sequence opens the **Split Edge** form.

Split Edge									
Edge	edge.2 								
Type	Real connected 								
Split With	Point 								
U Value	0.443666								
Coordinate Sys.	C_sys.1 								
Type	Cylindrical 								
<table border="1"> <thead> <tr> <th>Global</th> <th>Local</th> </tr> </thead> <tbody> <tr> <td>x: 24.5385</td> <td>r: 31.999949</td> </tr> <tr> <td>y: -20.5392</td> <td>t: -39.929985</td> </tr> <tr> <td>z: 0</td> <td>z: 0</td> </tr> </tbody> </table>		Global	Local	x: 24.5385	r: 31.999949	y: -20.5392	t: -39.929985	z: 0	z: 0
Global	Local								
x: 24.5385	r: 31.999949								
y: -20.5392	t: -39.929985								
z: 0	z: 0								
<table border="1"> <tr> <td>Apply</td> <td>Reset</td> <td>Close</td> </tr> </table>		Apply	Reset	Close					
Apply	Reset	Close							

- a) Select the large arc as the edge to split by using the **Edge** pick list.

Note that you could select the edge in the graphics window; a pick list provides an alternate way of picking an element.

- i. Left-click the black arrow to the right of the **Edge** list box in the **Split Edge** form.

This action opens the **Edge List** form. There are two types of pick-list forms: **Single** and **Multiple**. In a **Single** pick-list form, only one entity can be selected at a time. In a **Multiple** pick-list form, you can select multiple entities.

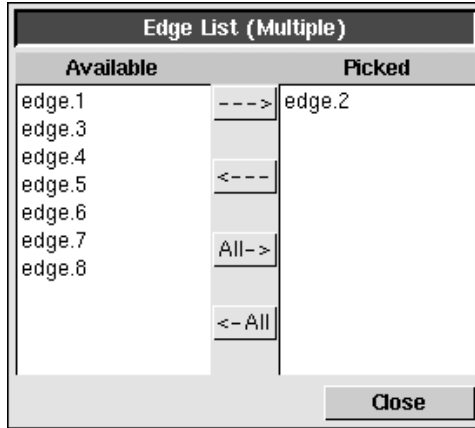

- ii. Select *edge.2* under **Available** in the **Edge List** form.

! Note that the **Available** names may be different in your geometry, depending on the order in which you created the edges.

- iii. Click the $--->$ button to pick *edge.2*.

edge.2 will be moved from the **Available** list to the **Picked** list. The large arc is the edge that should be selected and shown in red in the graphics window.

- iv. Close the **Edge List** form.

This method of selecting an entity can be used as an alternative to Shift-left-click in the graphics window. See the *GAMBIT User's Guide* for more information on pick lists.

- b) Select Real connected (the default) under **Type** in the **Split Edge** form.

You should select this option because the edge you selected is real geometry, not virtual geometry, and because you want the two edges created by the split to share the vertex created when GAMBIT does the split. See the GAMBIT Modeling Guide for more information on real and virtual geometry.

- c) Select Point (the default) to the right of **Split With**.

You will split the edge by creating a point on the edge and then using this point to split the edge.

- d) Select Cylindrical from the **Type** option menu.

You can now use cylindrical coordinates to specify where GAMBIT should split the edge.

- e) Input a value of -39.93 degrees next to **t** under **Local**.

This is the angle between the horizontal direction and the position of the right-hand side of the opening of the small pipe on the bend of the mixing elbow, as shown in Figure 2-1.

- f) Click **Apply**.

The large arc is split into two smaller arcs and a vertex is created.

- g) Use the **Edge List** form (or *Shift*-left-click in the graphics window) to select the larger of the two arcs just created (*edge.9*).

- h) Input a value of -50.07 degrees next to **t** under **Local**.

This is the angle between the horizontal direction and the position of the left-hand side of the opening of the small pipe on the bend of the mixing elbow ($-90^\circ + 39.93^\circ$), as shown in Figure 2-1.

- i) Click **Apply**.

The arc is split into two parts and a second vertex is created on the bend of the mixing elbow, as shown in Figure 2-9.

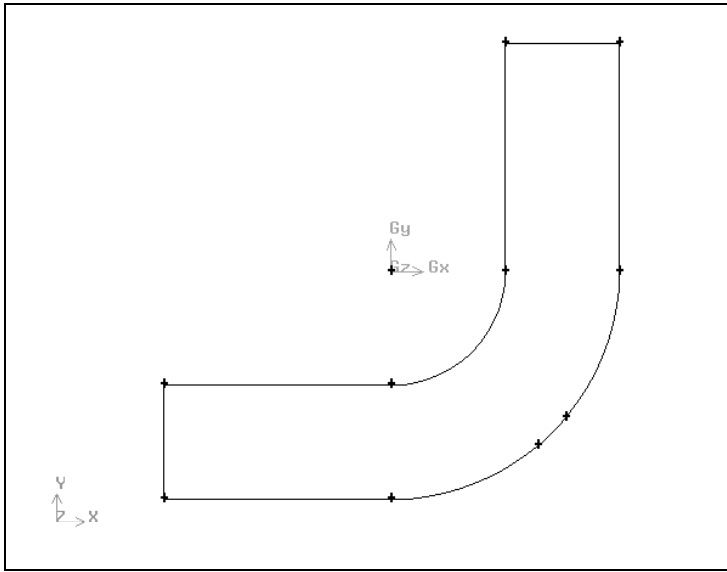

Figure 2-9: Vertices created on outer radius of mixing elbow bend

2. Create points at the small inlet.

GEOMETRY  → VERTEX  → MOVE/COPY VERTICES 

*This command sequence opens the **Move / Copy Vertices** form.*

- a) Select the second vertex created on the bend of the mixing elbow.
- b) Select **Copy** under **Vertices** in the **Move / Copy Vertices** form.
- c) Select **Translate** (the default) under **Operation**.
- d) Enter the translation vector (0, -12, 0) under **Global** to create the new vertex at a position 12 units below the vertex you selected.

The inlet is 12 units below the second point created on the outer radius of the bend.

*Note that GAMBIT automatically fills in the values under **Local** as you enter values under **Global**.*

- e) Click **Apply**.
- f) Click the **FIT TO WINDOW**  command button at the top left of the **Global Control** toolpad to scale the model to fit into the graphics window.

- g) Select the vertex just created in the graphics window.
- h) Enter the translation vector (4, 0, 0) under **Global** in the **Move / Copy Vertices** form to create the new vertex at a position 4 units to the right of the vertex you selected.
- i) Click **Apply**.

The vertices are shown in Figure 2-10.

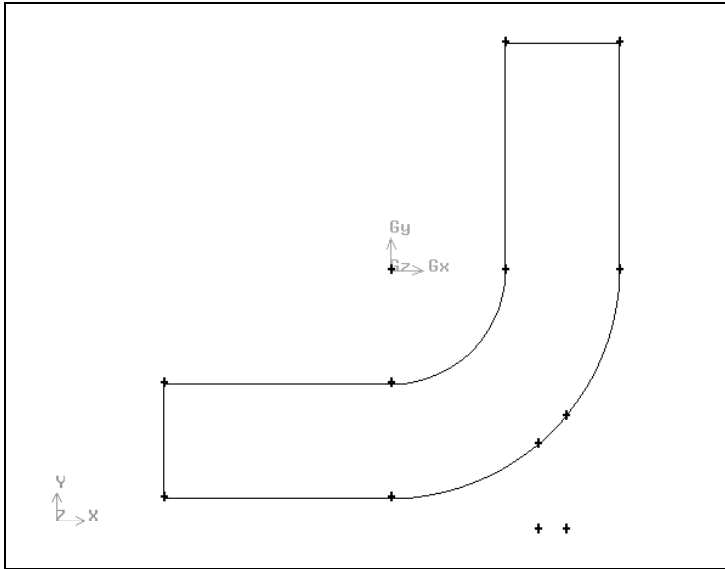
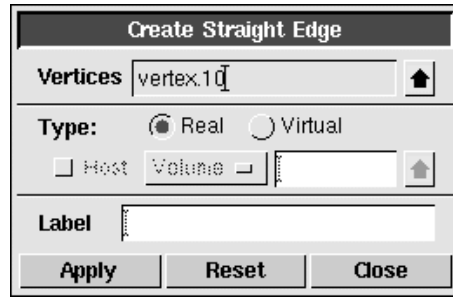

Figure 2-10: Vertices to define the small pipe

- 3. Create straight edges for the small pipe.



*This command sequence opens the **Create Straight Edge** form.*



- a) Create straight edges for the small pipe by selecting the vertices marked K, L, M, and J in Figure 2-11, in order, and accepting the selection.

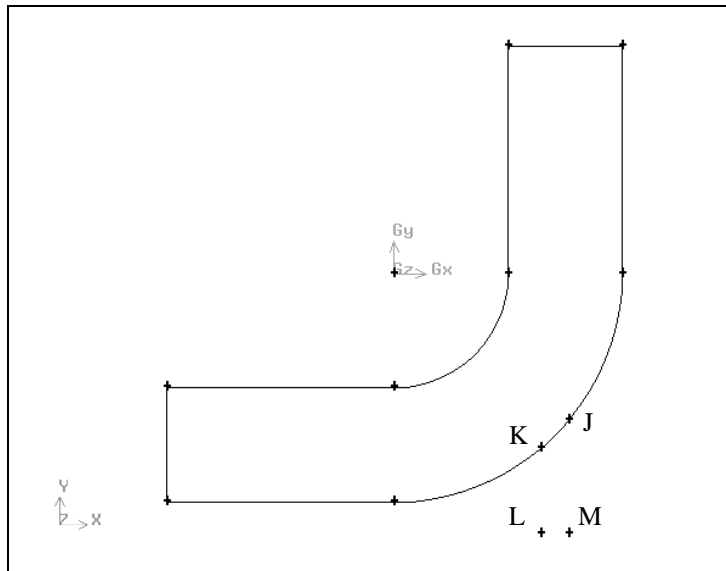

Figure 2-11: Vertices to be used to create small pipe

The small pipe is shown (with the large pipe) in Figure 2-12.

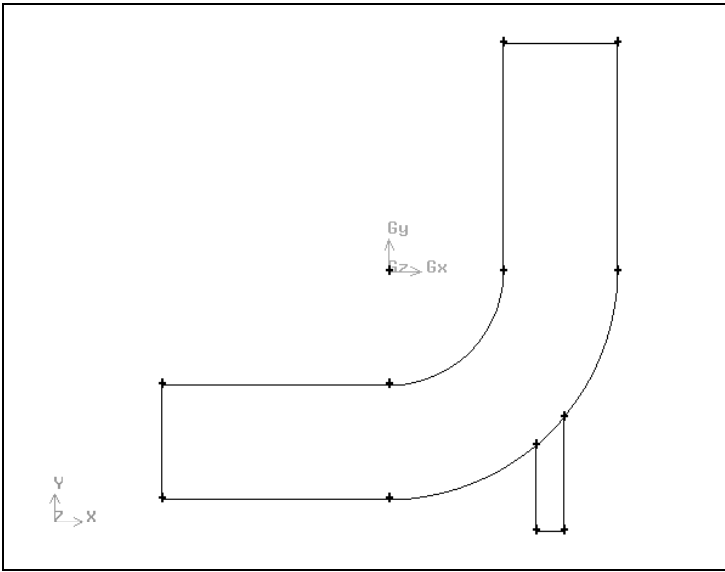

Figure 2-12: Completed small pipe

Step 6: Create Faces From Edges

1. Create a face for the large pipe.



*This command sequence opens the **Create Face From Wireframe** form.*

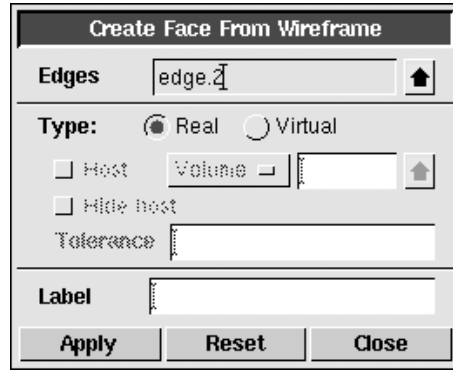

- a) *Shift-left-click* each edge of the large pipe, in turn, to form a continuous loop.

! *The large pipe is created from the 10 edges shown in Figure 2-13. If you select an incorrect edge, click **Reset** in the **Create Face From Wireframe** form to unselect all edges, and then reselect the correct edges.*

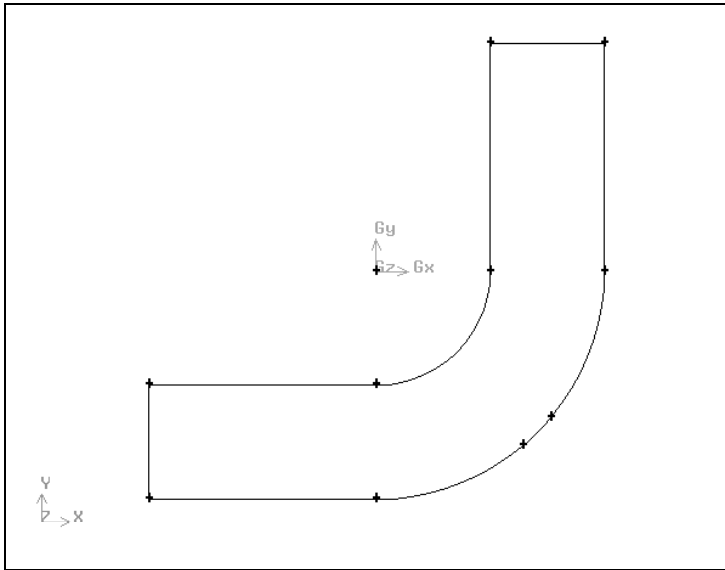

Figure 2-13: Edges used to create face for large pipe

Note that the edges must form a continuous loop, but they can be selected in any order. An alternative method to select several edges is to Shift-left-drag a box around the edges. The box does not have to completely enclose the edges; it only needs to enclose a portion of an edge to select it. The edges will be selected when you release the mouse button.

- b) Click **Apply** to accept the selected edges and create a face.

The edges of the face will turn blue.

2. Create a face for the small pipe by selecting the four edges shown in Figure 2-14 and then accepting the selected edges.

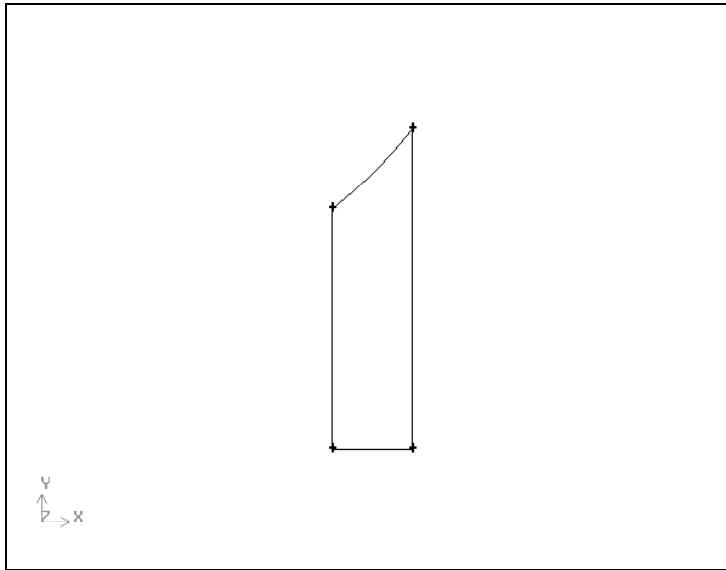

Figure 2-14: Edges used to create face for small pipe

Step 7: Specify the Node Distribution

The next step is to define the grid density on the edges of the geometry. You will accomplish this graphically by selecting an edge, assigning the number of nodes, and specifying the distribution of nodes along the edge.

1. Specify the node density on the inlet and outlet of the large pipe.



This command sequence opens the Mesh Edges form.

Mesh Edges

Edges

Pick with links

Soft link

Use first edge settings

Grading Apply

Type

Double sided

Ratio 1

Ratio 2

Spacing Apply

Options Mesh
 Remove old mesh
 Ignore size functions

- a) Shift-left-click the edge marked EA in Figure 2-15.

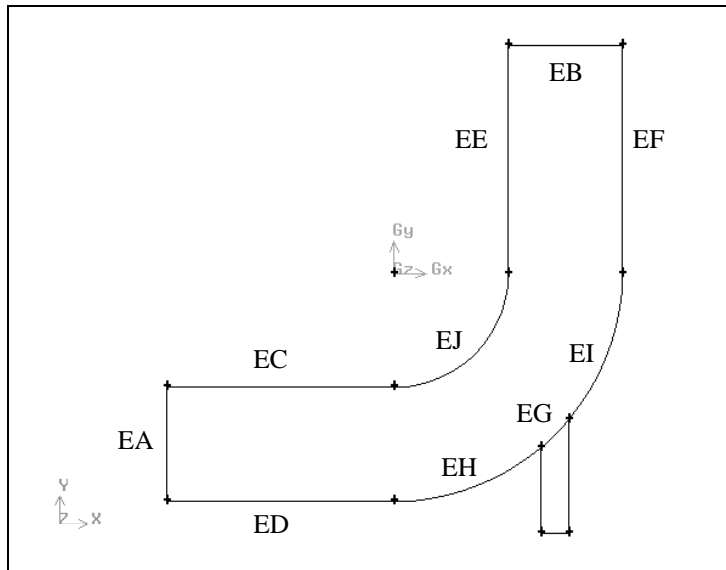

Figure 2-15: Edges to be meshed

The edge will change color and an arrow and several circles will appear on the edge.

- b) Shift-left-click the edge marked EB in Figure 2-15.
- c) Check that **Apply** is selected to the right of **Grading** in the **Mesh Edges** form and that **Successive Ratio** is selected in the **Type** option menu.

*The Successive Ratio option sets the ratio of distances between consecutive points on the edge equal to the specified **Ratio**.*

- d) Enter 1.25 in the text entry box to the right of **Ratio**.

*Alternatively, you can slide the **Ratio** slider box (the small, gray rectangle with a vertical line in its center that is located on the slider bar) until 1.25 is displayed in the **Ratio** text box.*

- e) Select the Double sided check box under **Grading**.

If you specify a Double sided grading on an edge, the element intervals are graded in two directions from a starting point on the edge. GAMBIT determines the starting point such that the intervals on either side of the point are approximately the same length.

*Note that **Ratio** changes to **Ratio 1** and **Ratio 2** when you select the Double sided check box. In addition, the value you entered for **Ratio** is automatically entered into both the **Ratio 1** and the **Ratio 2** text entry boxes.*

- f) Select Interval count from the option menu under **Spacing** and enter a value of 10 in the text entry box. Check that **Apply** is selected to the right of **Spacing**.

GAMBIT will create 10 intervals on the edge.

- g) Click the **Apply** button at the bottom of the form.

Figure 2-16 shows the mesh on the inlet and outlet edges of the large pipe.

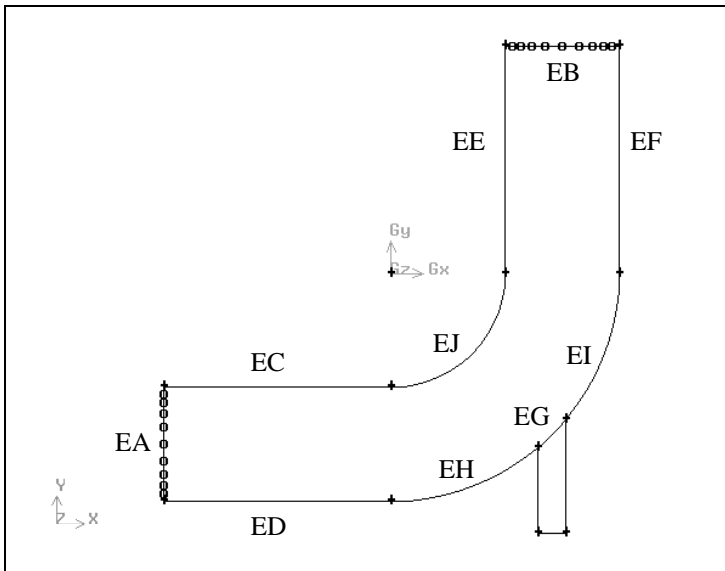

Figure 2-16: Edge meshing on inlet and outlet of large pipe

2. Mesh the four straight edges of the large pipe.
 - a) Select the edges marked EC, ED, EE, and EF in Figure 2-16.
 - b) Check that **Apply** is selected to the right of **Grading** in the **Mesh Edges** form and click the **Default** button to the right of **Grading**.

*GAMBIT will unselect the Double sided check box and set the **Ratio** to 1.*

- c) Check that **Apply** is selected to the right of **Spacing** and select **Interval count** from the option menu.
 - d) Enter a value of 15 in the text entry box below **Spacing** and click the **Apply** button at the bottom of the form.

Figure 2-17 shows the mesh on the straight edges of the large pipe.

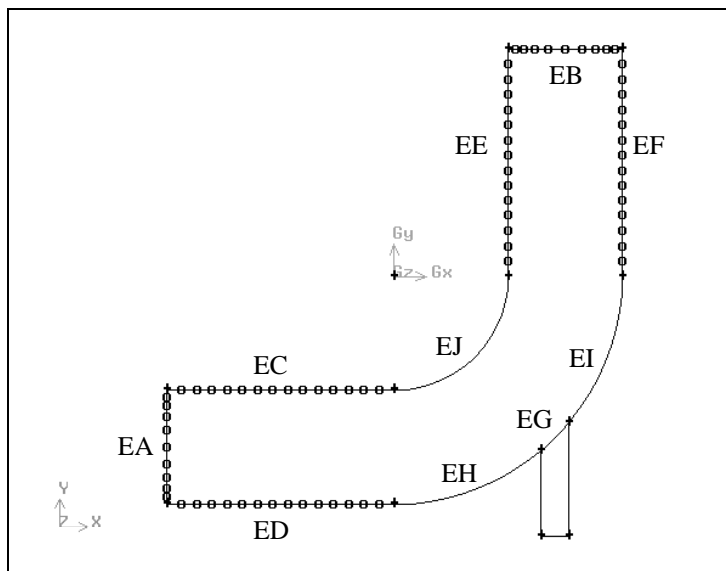

Figure 2-17: Mesh on the straight edges of the large pipe

3. Mesh the edge connecting the two pipes.
 - a) Select the edge marked EG in Figure 2-17.
 - b) Check that **Apply** is selected to the right of **Grading** in the **Mesh Edges** form and enter a value of 1 for the **Ratio**.
 - c) Check that **Apply** is selected to the right of **Spacing**, select Interval count from the option menu, and enter a value of 6 in the text entry box below **Spacing**.
 - d) Click the **Apply** button at the bottom of the form.
4. Mesh the two edges on the outer radius of the bend of the mixing elbow.
 - a) Select the edge marked EH in Figure 2-17. The arrow should point towards the small pipe. *Shift*-middle-click the edge to reverse the direction of the arrow if necessary.

! The arrow is small and you may have to zoom into the edge to see it. It is located near the center of the edge.
 - b) Select the edge marked EI in Figure 2-17. The arrow should point towards the small pipe. *Shift*-middle-click the edge to reverse the direction of the arrow if necessary.
 - c) Check that **Apply** is selected to the right of **Grading** in the **Mesh Edges** form and enter a value of 0.9 for the **Ratio**.
 - d) Check that **Apply** is selected to the right of **Spacing**, select Interval count from the option menu, and enter a value of 12 in the text entry box below **Spacing**.
 - e) Click the **Apply** button at the bottom of the form.

The mesh on the two edges on the outer radius of the bend is shown in Figure 2-18.

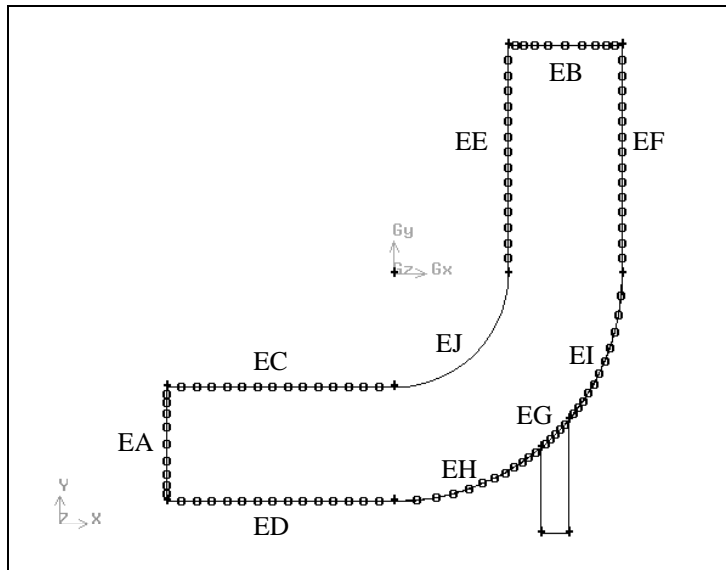

Figure 2-18: Mesh on outer bend of pipe

5. Set the grading for the inner bend of the mixing elbow.
 - a) Select the edge marked EJ in Figure 2-18.
 - b) Check that **Apply** is selected to the right of **Grading** in the **Mesh Edges** form and enter a value of 0.85 for the **Ratio**.
 - c) Select the Double sided check box.
 - d) Unselect the **Apply** check box to the right of **Spacing**.

You will not set a spacing on this edge, instead you will let GAMBIT calculate the spacing for you when it meshes the face. You will mesh the face using a mapped mesh, so the number of nodes on the inner bend of the mixing elbow must equal the number of nodes on the outer bend, and GAMBIT will determine the correct number of nodes for you automatically.

- e) Unselect the **Mesh** check box under **Options** and click the **Apply** button at the bottom of the form.

*You unselected the **Mesh** check box because at this point you do not want to mesh the edge; you only want to apply the **Grading** to the edge. GAMBIT will mesh the edge using the specified **Grading** when it meshes the large pipe of the mixing elbow in the next step.*

Figure 2-19 shows the edge meshing for the mixing elbow geometry.

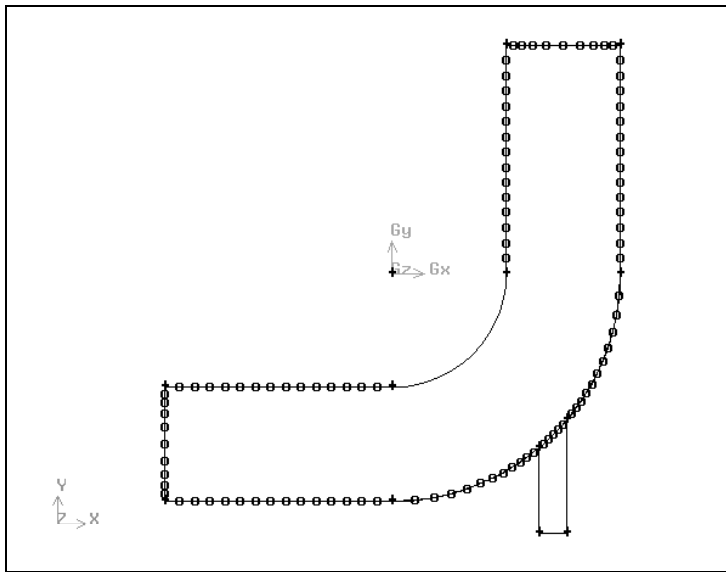

Figure 2-19: Edge meshing for the mixing elbow

Step 8: Create Structured Meshes on Faces

1. Create a structured mesh for the large pipe.



This command sequence opens the **Mesh Faces** form.

Mesh Faces	
Faces	face.1
Scheme:	<input checked="" type="checkbox"/> Apply <input type="checkbox"/> Default
Elements:	Quad
Type:	Map
Smoother:	None
Spacing:	<input checked="" type="checkbox"/> Apply <input type="checkbox"/> Default
	1 Interval size
Options:	<input checked="" type="checkbox"/> Mesh
	<input type="checkbox"/> Remove old mesh
	<input type="checkbox"/> Remove lower mesh
	<input type="checkbox"/> Ignore size functions
<input type="button" value="Apply"/> <input type="button" value="Reset"/> <input type="button" value="Close"/>	

- a) *Shift*-left-click the large pipe in the graphics window.

Note that four of the vertices on this face are marked with an “E” in the graphics window; they are End vertices. Therefore, GAMBIT will select the Map Type of Scheme in the Mesh Faces form. See the GAMBIT Modeling Guide for more information on Map meshing.

- b) Click the **Apply** button at the bottom of the form.

GAMBIT will ignore the Interval size of 1 under Spacing, because the mapped meshing scheme is being used and the existing edge meshing fully determines the mesh on all edges.

Notice that GAMBIT calculates the number of nodes on the inner bend of the mixing elbow and displays these nodes before creating the mesh on the face. The face will be meshed as shown in Figure 2-20.

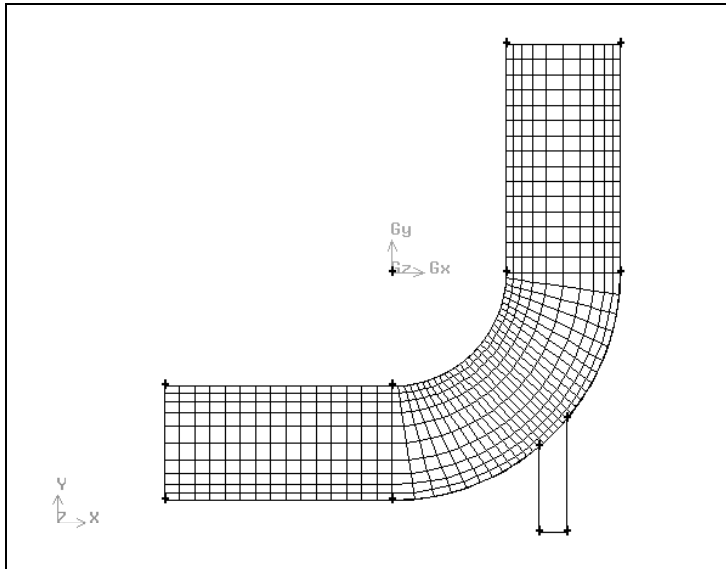

Figure 2-20: Structured mesh on the large pipe of the mixing elbow

2. Mesh the small pipe of the mixing elbow.

- a) Select the small pipe in the graphics window.

You will force GAMBIT to use the Map scheme to mesh the smaller face.

- b) In the **Mesh Faces** form, select Quad from the **Elements** option menu under **Scheme** and Map from the option menu to the right of **Type**.

This is an example of “enforced mapping”, where GAMBIT automatically modifies the face vertex type on the face to satisfy the chosen meshing scheme. See the GAMBIT Modeling Guide for more information on face vertex types.

- c) Retain the default Interval size of 1 under **Spacing** and click the **Apply** button at the bottom of the form.

The structured mesh for the entire elbow is shown in Figure 2-21.

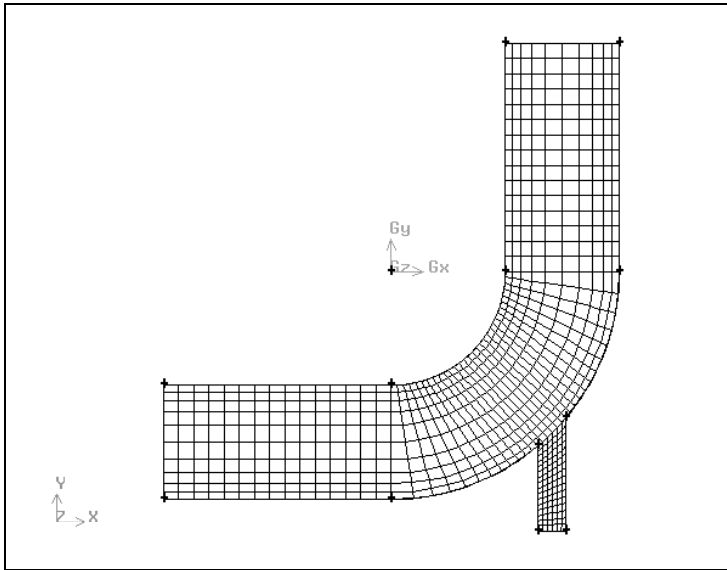



Figure 2-21: Structured mesh for the mixing elbow

Step 9: Set Boundary Types

1. Remove the mesh from the display before you set the boundary types.

This makes it easier to see the edges and faces of the geometry. The mesh is not deleted, just removed from the graphics window.

- a) Click the **SPECIFY DISPLAY ATTRIBUTES** command button  at the bottom of the **Global Control** toolpad.
- b) Select the Off radio button to the right of **Mesh** near the bottom of the form.
- c) Click **Apply** and close the form.

2. Set boundary types for the mixing elbow.

ZONES  → SPECIFY BOUNDARY TYPES 

*This command sequence opens the **Specify Boundary Types** form.*

Specify Boundary Types

FLUENT 4

Action:
 Add Modify
 Delete Delete all

Name	Type
inflow1	INFLOW
inflow2	INFLOW
outflow	OUTFLOW

Show labels Show colors

Name:

Type:

Entity:

Label	Type
edge.7	Edge

Note that FLUENT 4 is shown as the chosen solver at the top of the form. The Specify Boundary Types form displays different Types depending on the solver selected.

- a) Define two inflow boundaries.
 - i. Enter the name inflow1 in the **Name** text entry box.

*If you do not specify a name, GAMBIT will give the boundary a default name based on what you select in the **Type** and **Entity** lists.*

- ii. Select INFLOW in the **Type** option menu.

- iii. Change the **Entity** to Edges by selecting Edges in the option menu below **Entity**.
- iv. *Shift*-left-click the main inflow for the mixing elbow in the graphics window (marked EA in Figure 2-22) and click **Apply** to accept the selection.

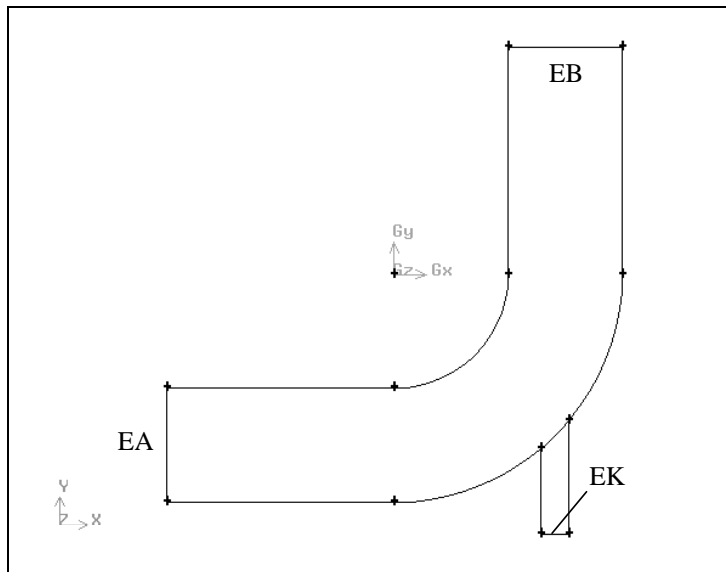

Figure 2-22: Boundary types for edges of mixing elbow

This edge will be set as an inflow boundary.

- v. Enter `inflow2` in the **Name** text entry box.
 - vi. Check that **INFLOW** is still selected in the **Type** option menu and select the edge marked EK in Figure 2-22 (the inlet for the small pipe). Click **Apply** to accept the selection of the edge.
- b) Define an outflow boundary.
- i. Enter `outflow` in the **Name** text entry box.
 - ii. Change the **Type** to **OUTFLOW** by selecting **OUTFLOW** in the option menu below **Type**.
 - iii. Select the main outflow for the mixing elbow (the edge marked EB in Figure 2-22) and click **Apply** to accept the selection.

The inflow and outflow boundaries for the mixing elbow are shown in Figure 2-23. (**NOTE:** To display the boundary types in the graphics window, select the **Show labels** options on the **Specify Boundary Types** form.)

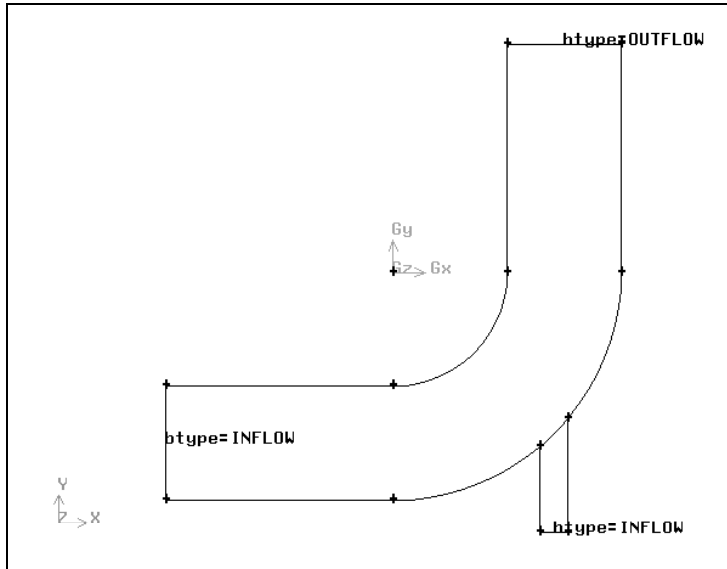

Figure 2-23: Inflow and outflow boundaries for the mixing elbow

Note that you could also specify the remaining outer edges of the mixing elbow as wall boundaries. This is not necessary, however, because when GAMBIT saves a mesh, any edges (in 2-D) on which you have not specified a boundary type will be written out as wall boundaries by default. In addition, when GAMBIT writes a mesh, any faces (in 2-D) on which you have not specified a continuum type will be written as FLUID by default. This means that you do not need to specify a continuum type in the **Specify Continuum Types** form for this tutorial.

Step 10: Export the Mesh and Save the Session

1. Export a mesh file for the mixing elbow.

File → Export → Mesh...

This command sequence opens the Export Mesh File form. Note that the File Type is Structured FLUENT 4 Grid.

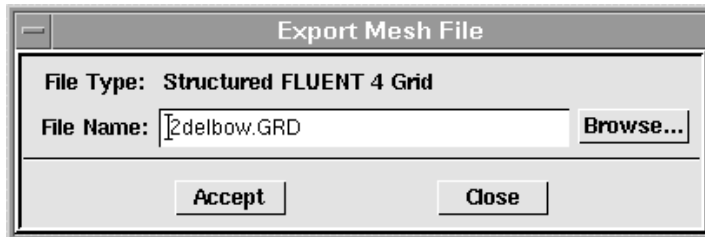

- a) Enter the **File Name** for the file to be exported (2-DELBOW.GRD).
- b) Click **Accept**.

The file will be written to your working directory.

2. Save the GAMBIT session and exit GAMBIT.

File → Exit

GAMBIT will ask you whether you wish to save the current session before you exit.

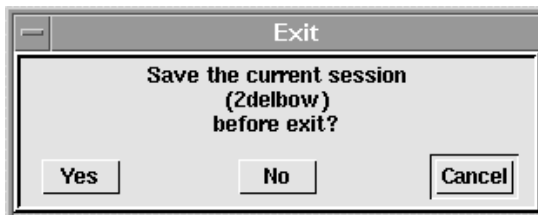

Click **Yes** to save the current session and exit GAMBIT.

2.5 Summary

This tutorial shows you how to generate a 2-D mesh using the “bottom-up” approach. Since the mesh is to be used in FLUENT 4, it was generated in a single block, structured fashion. Several other features that are commonly used for 2-D mesh generation were also demonstrated, including entering vertices using a background grid, creating straight edges and arcs, and specifying node distributions on individual edges. As compared to Tutorial 1, which omitted some details, all steps required to create a mesh ready to read into the solver were covered, including how to set boundary types, choose a specific Fluent solver, and finally write out the mesh file.