

Copyright 2005 Society of Photo-Optical Instrumentation Engineers.

This paper was (will be) published in Proc. SPIE vol. 5699 and is made available as an electronic reprint (preprint) with permission of SPIE. One print or electronic copy may be made for personal use only. Systematic or multiple reproduction, distribution to multiple locations via electronic or other means, duplication of any material in this paper for a fee or for commercial purposes, or modification of the content of the paper are prohibited.

The Anti-Brownian ELectrophoretic Trap (ABEL Trap): Fabrication and Software

Adam E. Cohen,* Dept. of Physics, Stanford University, 382 via Pueblo Mall, Stanford, CA 94305
W. E. Moerner, Dept. of Chemistry, M/C 5080, 375 North-South Mall, Stanford, CA 94305-5080

**To whom correspondence should be addressed: aecohen@stanford.edu*

ABSTRACT

The Anti-Brownian ELectrophoretic trap (ABEL trap) is a new device that allows a user to trap and manipulate fluorescent objects as small as 20 nm freely diffusing in solution. We describe in detail how to build an ABEL trap.

CHALLENGES IN NANOMANIPULATION

One of the outstanding challenges of nanotechnology is to develop a means to trap and manipulate individual molecules in solution. To study a biomolecule one would like to hold the molecule still, to turn it around, to pull on its ends, and to bring it into contact with other molecules—all in a highly controlled manner and in the molecule's native environment. Such a level of control would also allow one to build custom molecular-assemblies designed for specific tasks.

Laser tweezers have led to a revolution in the fields of nanomanipulation and biophysics.¹ Single-² and multiple-³ beam optical traps have been used to assemble structures from dielectric microparticles; to probe the intrinsic mechanical properties of DNA and RNA; and to probe the action of DNA-processive enzymes. Although less widespread, magnetic tweezers,⁴ and AC dielectrophoresis⁵ have also been used to trap and manipulate micron-scale objects. Unfortunately, all of these techniques fail for molecule-sized objects because the trapping force is proportional to the volume of the trapped object: to trap a 10 nm object requires a million times as much input power as to trap a 1-micron object.

Biophysicists seeking to study individual molecules have a limited set of options for confining the molecule. One common practice is to immobilize the molecule on a surface.⁶ Unfortunately surface chemistry is notoriously finicky, and there is a persistent doubt whether the tied-down molecule acts the same as its free-solution comrades. Another technique is to immobilize the molecule in the pores of a gel.⁷ However, if the pores are small enough to confine the molecule, then it is difficult to get the molecule *into* the pores in the first place. Finally, in fluorescence correlation spectroscopy (FCS), molecules in free-solution are observed as they diffuse through a tightly focused laser beam.⁸ While these molecules may be in their native environment, the short residence times of FCS (typically a few milliseconds), limit the technique to the study of fast processes. Many biological processes occur on the timescale of seconds to hours. As a concrete example of the problem facing

single-molecule researchers, nobody has found a way to observe the catalytic cycle of the chaperonin GroEL, which takes 7 – 15 seconds, without disturbing this cycle.

The Paul trap and Dehmelt's improvements on the Penning trap allowed scientists to observe individual gas-phase ions for long times. These traps have been used in basic physics to measure the magnetic moment of the electron, and are also widely used as an analytical tool in mass-spectrometry. To-date, no equivalent tool has been developed for studying single-molecules in solution.

Feedback control is widely used to stabilize the motion of stochastic systems, where the stochasticity may arise from quantum, thermal, or manufacturing fluctuations. In particular, feedback may be used to cancel the Brownian motion of a single nanoscale object in solution, over some finite bandwidth. In contrast to passive trapping schemes, feedback trapping has the advantage that the applied potential need not have any local minima. Recent proposals have discussed using feedback to track the Brownian motion of individual fluorescent molecules in solution.^{9,10} For nanoscale objects, electrophoretic forces are far stronger than either magnetic or optical forces and are thus most amenable to inclusion in a feedback system.

THE ANTI-BROWNIAN ELECTROPHORETIC TRAP (ABEL TRAP)

Over the past year and a half, we have developed an *Anti-Brownian E*lectrophoretic trap (ABEL trap): a device that uses quasi-DC electric fields and digital feedback to manipulate individual nanoscale objects in solution at ambient temperature. We have trapped *individual* 20 nm polystyrene nanospheres, 100 nm lipid vesicles, ~700 nm (radius of gyration) molecules of λ -DNA, and particles of tobacco mosaic virus. Unlike other trapping schemes, the trapping performance of the ABEL trap scales favorably for small particles.^{11,12}

The ABEL trap works by monitoring the Brownian motion of the particle (via fluorescence microscopy), and then applying a feedback voltage to the solution so that the electrophoretic drift exactly cancels the Brownian motion. The drift can be due either to the direct action of the field on the object's charge, or to an electroosmotic flow which creates a drag on the object. The incarnation described here relies on electroosmotic flow, although we have used both effects to trap objects. The ABEL trap works on any object that can be imaged optically and that can be dispersed in water. The ABEL trap is non-invasive, is gentle enough to handle biological molecules, and can trap objects far smaller than can be trapped with laser tweezers.

In this article we describe in detail how to build an ABEL trap and the software that controls the ABEL trap.

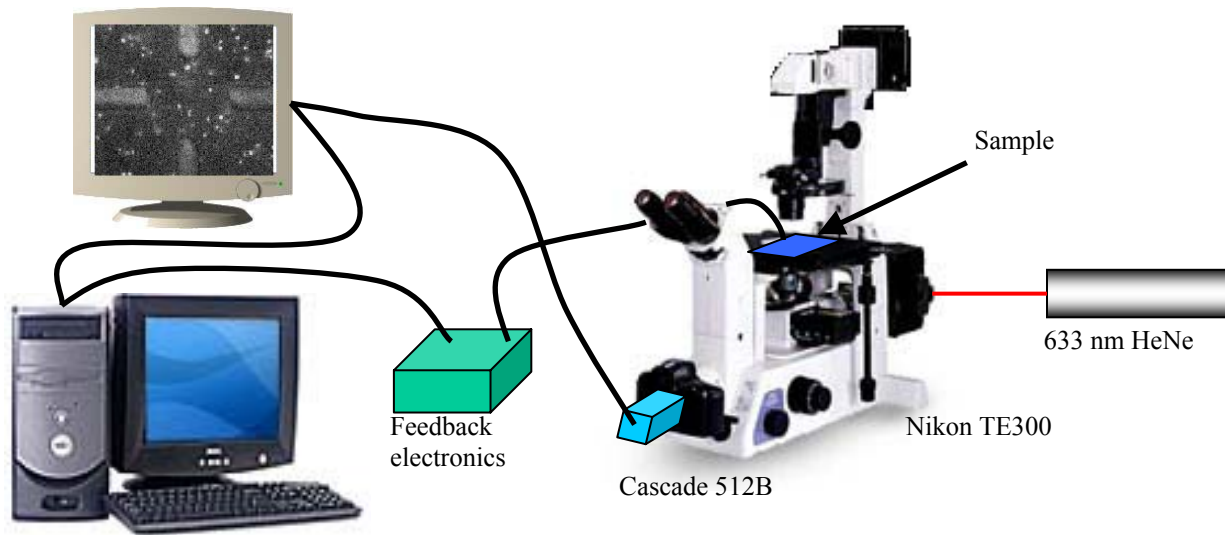

2.8 GHz Pentium IV
 NI IMAQ PCI-1407 frame grabber
 NI PCI-MIO-16E-4 DAQ card
 Visual Basic 5.0

Figure 1. System configuration for the ABEL trap.

OVERVIEW OF THE HARDWARE

Figure 1 shows the system configuration of the ABEL trap. A laser beam illuminates the sample in a fluorescence microscope. Fluorescence images are collected by a Cascade 512B camera (Roper Scientific), and sent to a monitor and a computer. The computer calculates a feedback voltage, which is filtered and scaled by the feedback electronics. The feedback signal is then applied to the sample in order to induce the appropriate electrophoretic drift.

A poly-dimethyl siloxane (PDMS) microfluidic cell forms the heart of the ABEL trap (Fig. 2). The cell is designed so that a voltage applied to a set of electrodes leads to an arbitrary in-plane electroosmotic flow in the center of the trap. This flow carries dissolved species with it. By continuously adjusting the magnitude and direction of the flow, we can cancel the Brownian motion of one object of interest.

Sample cells were fabricated in the Stanford Nanofabrication Facility (SNF) using the procedure illustrated in Figure 3. The sample cell contains channels of two different depths: a shallow (880 nm) channel forms the trapping region and deep (20 μm) channels connect the trapping region to macroscopic electrodes. It was necessary to use a thin channel in the trapping region to confine trapped objects to the focal plane of the microscope (the present incarnation of the ABEL trap does not provide feedback trapping in the z-direction). It was also necessary to use thick channels to connect the trapping region to the macroscopic electrodes to avoid resistive losses in these channels and to allow the channels to fill easily.

A template for the PDMS cell was formed in two stages of photolithography on a 4" Si wafer. Initially we used a conventional chrome-on-quartz mask to pattern the Si master. We found, however, that equally good results were obtained using high-resolution transparency masks, at a significant saving of cost and effort. Once a master was made with 40 copies of the pattern, it could be used repeatedly to fabricate batches of 40 sample cells. Thus we were able to use the sample cells disposably, avoiding the risk of cross-contamination between experiments.

The PDMS stamp and a glass coverslip were exposed to a plasma of low-pressure room air for 1 minute and then irreversibly bonded to each other. The plasma treatment made the surfaces hydrophilic and negatively charged, which led to strong electroosmotic flow.

A major challenge was to eliminate pressure-driven flows in the trapping region. The cross-sectional area of the trapping region ($20\ \mu\text{m} \times 880\ \text{nm}$) is roughly 800 times smaller than that of the microfluidic channels connecting to the electrodes ($700\ \mu\text{m} \times 20\ \mu\text{m}$). Thus even slight flows in the channels lead to very large flow velocities in the trapping region. We balanced the pressure in the channels by immersing the entire cell in a water bath (Fig. 4).

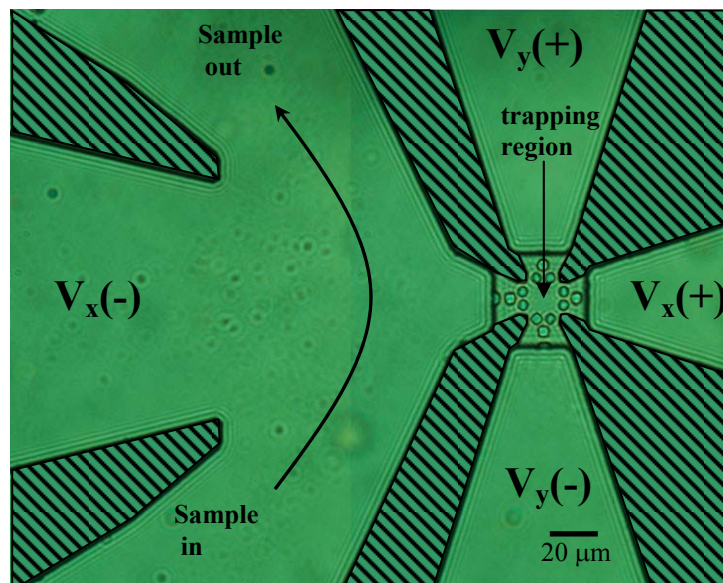

Figure 2. Trapping region of the ABEL trap, formed from an oxidized PDMS stamp and a glass coverslip. The trapping region is $\sim 20\ \mu\text{m}$ across and $880\ \text{nm}$ deep. This depth allows free diffusion of submicron particles, while still confining the particles to the focal plane of the microscope. The small circles surrounding the trapping region are support posts to keep the PDMS from collapsing onto the glass coverslip. The channels extending to the edges of the image are $\sim 20\ \mu\text{m}$ deep and extend $\sim 7\ \text{mm}$ away from the trapping region, where they are connected to macroscopic copper electrodes. The channel on the left splits into three to allow for easy and rapid sample delivery. Regions of PDMS in contact with the glass have been crosshatched for clarity.

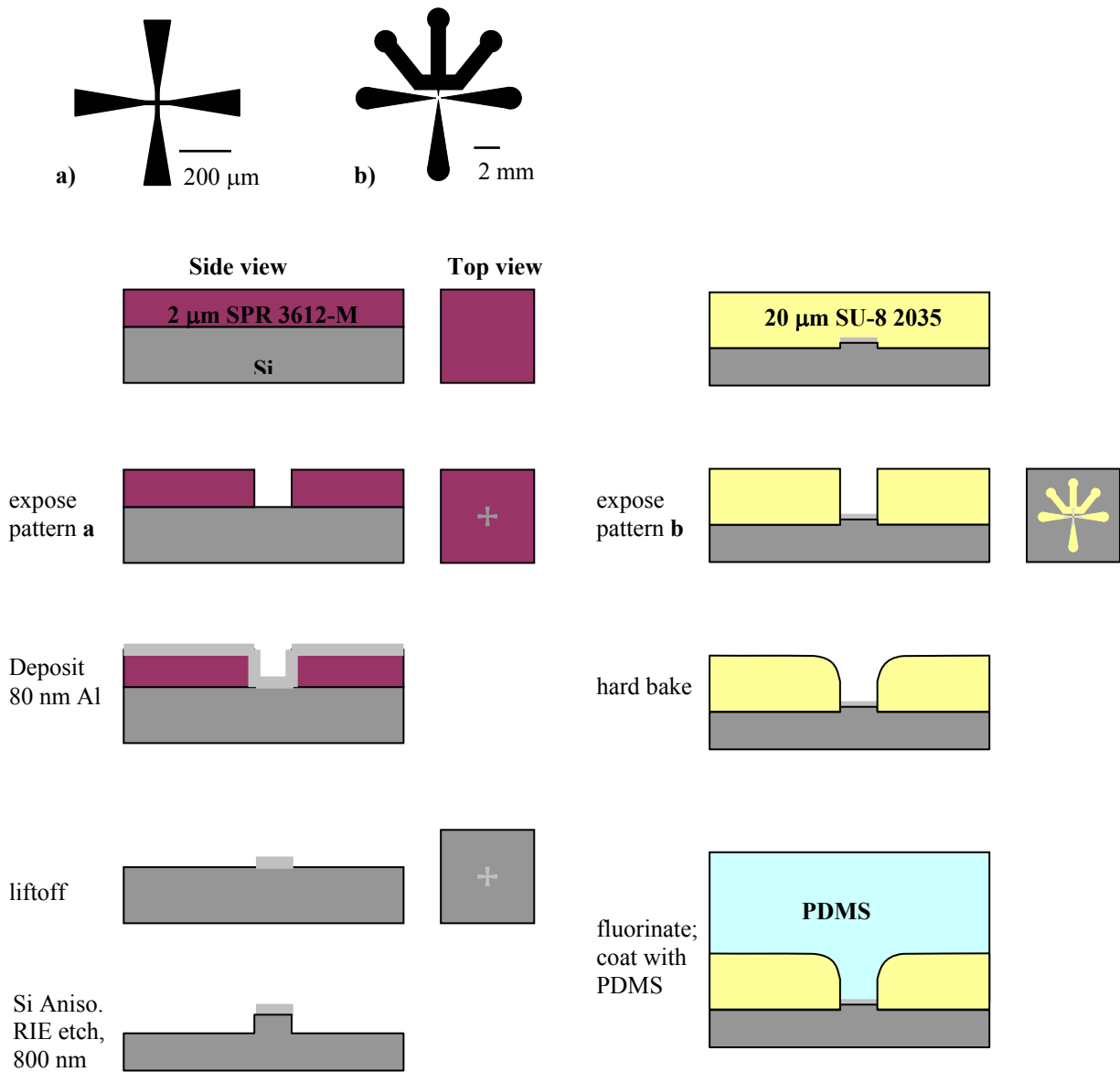

Figure 3. Process for making PDMS microfluidic cell. Top: Mask patterns were printed on a transparency. Each mask contains ~40 copies of the pattern. Bottom: Processing steps. The central trapping region was patterned on a 4" wafer. The Al overcoat on the mesas made the mesas easy to locate for alignment with the second layer of lithography. The hard-bake of the SU-8 (150 C, 2 hrs.), strengthened the film and rounded the corners creating a draft angle for easy removal of the PDMS. To prevent adhesion of the PDMS, the master was put in a dessicator in vacuum with a drop of trichloro(1H,1H,2H,2H perfluoreoctyl)silane (Aldrich) for 1 hr. prior to applying PDMS.

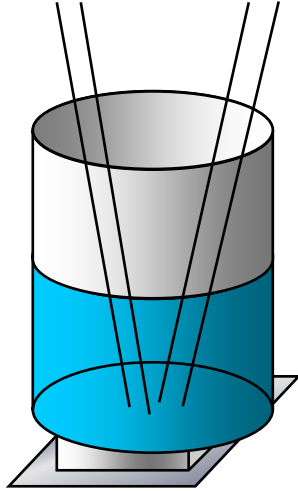
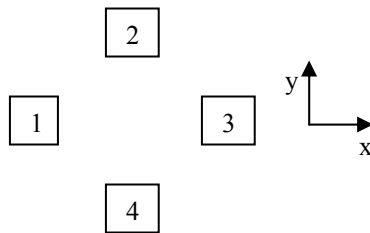

Figure 4. Holder for the sample cell. The sample cell is epoxied to the bottom of a plastic jar, and access holes are punched through the bottom of the jar and through the PDMS. The sample cell is filled with a solution of objects to be trapped by pipetting. Excess buffer is then added to the plastic jar to equalize the pressure in all arms of the sample cell. Insulated copper wires with exposed ends are inserted into the four control arms of the sample cell. The entire cell is mounted in a fluorescence microscope.

The sample cell is mounted in an inverted optical microscope equipped with a 100x, NA 1.4 oil immersion objective (Nikon *S Fluor*) and a 4x magnifier. The trapping region is illuminated with several mW of laser light. Our setup can be switched between illumination at 633 nm, 532 nm, 514 nm, or 488 nm. Fluorescence images are captured on a high-sensitivity CCD camera (Cascade 512B, Roper Scientific) at frame-rates of up to 300 Hz.

The ABEL trap has four electrodes whose potentials can be adjusted independently. This implies that there are three degrees of freedom in controlling the field (adding a constant to all potentials clearly has no effect on the field). Let the electrodes be numbered as:



We parameterize the three degrees of freedom as:

$$\begin{aligned}
 V_x &= V_1 - V_3 \\
 V_y &= V_4 - V_2 \\
 V_Q &= V_1 + V_3 - V_4 - V_2.
 \end{aligned}$$

V_x and V_y give the Cartesian components of the field in the center of the trapping region. V_Q is related to a quadrupole field. In this incarnation of the ABEL trap we set $V_Q = 0$, and also require that $V_1 + V_2 + V_3 + V_4 = 0$. These two requirements imply that $V_3 = -V_1$ and $V_2 = -V_4$. Our D/A card has only two analog outputs. The four drive voltages are generated with the simple circuit shown in Figure 4.

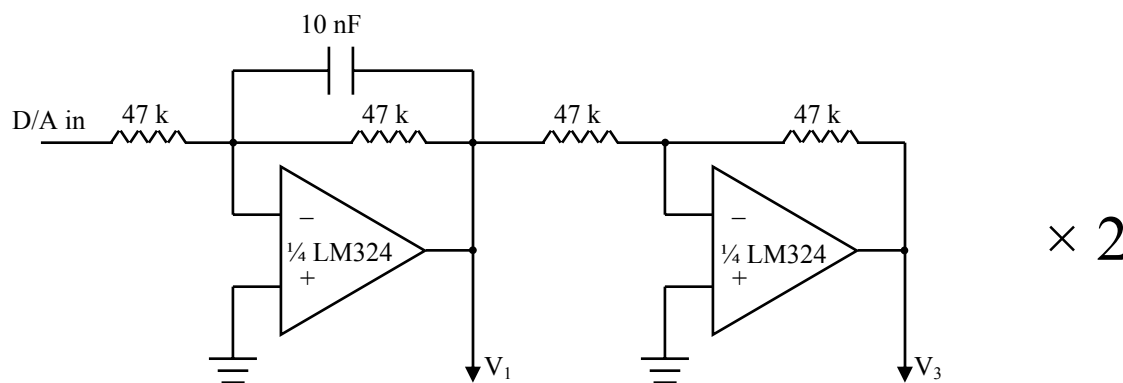

Figure 4. Control circuit for the ABEL trap. The circuit applies $\pm V_{out}$ to opposing electrodes, where V_{out} is the feedback voltage generated by the computer. The geometry of the sample cell concentrates the entire voltage drop across $\sim 20 \mu\text{m}$. Thus, unlike traditional capillary electrophoresis setups, the ABEL trap operates at low voltage. Typical feedback voltages are under 2 V.

CONTROL SOFTWARE

The computer controlling the ABEL trap must perform the following tasks:

- 1) Acquire images as they stream in from the camera;
- 2) Process the images in real-time to extract the x,y-coordinates of a single nanoparticle;
- 3) Calculate feedback voltages and send them to the D/A converter;
- 4) Display on the monitor an image of the trapping region, highlighting the trapped particle
- 5) Accept inputs from the user, such as mouse clicks indicating to move the target location or to trap a different particle.
- 6) Record and save video images, the trajectory of the trapped particle, and the applied feedback voltage.

The first three of these tasks must be performed in less than 3.4 ms, which is a typical interval between video frames from the camera. This requirement places stringent demands on the software and computer. Tasks 4 – 6 can take longer to execute, but they cannot delay the execution of the first three tasks by more than 3.4 ms.

The control software is run on a personal computer (Advantage PC, 2.8 GHz Pentium 4, Windows 2000). The software is written in Visual Basic 5.0, with the IMAQ Vision and ComponentWorks libraries from National Instruments and the PVCAM low-level camera-control library from Roper Scientific. Visual Basic is not a compiled language, so these libraries are key to achieving the requisite speed of the feedback loop.

The most critical design feature in the ABEL trap is achieving a short feedback latency. Much of the latency in our system comes from the camera. The Cascade 512B camera is a frame-transfer CCD imager with 512 x 512 pixels, on-chip gain, and a 10 MHz pixel readout clock. The frame-transfer process imposes an unavoidable delay of 2 ms on each frame. Reading out the image from the CCD causes a further delay. With a 16 x 16 Region of Interest (ROI), the total interframe interval (frame transfer plus readout) is 3.1 ms, and with a 32 x 32 ROI the interframe interval is 4.5 ms. The time for the computer to process an image depends on the image-size, and typically requires ~0.5 video frames. Thus the total latency in the feedback loop is ~1.5 video frames, or 4.6 ms with a 16 x 16 ROI and 6.8 ms with a 32 x 32 ROI. This feedback latency determines the smallest size of particle that the ABEL trap can trap.

We have written auxiliary software to quantify the feedback latency of the ABEL trap for any set of software parameters. An LED under computer control is pointed at the camera. The computer briefly flashes the LED, and then records how long it takes for the camera and image-processing software to register the flash. In this way we have been able to optimize the entire feedback system for maximum speed.

To maximize the speed of the image processing, a small sub-image (typically 15 x 15 pixels), which we term the “fovea,” is extracted from the raw image from the camera. This fovea is chosen to be small enough to contain on average only one particle, but large enough so that if the particle is in the center of the fovea during one frame, the particle is unlikely to have left the fovea entirely in the subsequent frame. In the first step of image processing, a background image is subtracted from the fovea. The background image is constructed by averaging many (typically 10 to 1000) video frames. The background subtraction is useful for removing signal from scattered laser light and from particles stuck to the surface. An optional flat-field correction then scales the intensity values in the fovea based on the spatial distribution of laser intensity. This is useful if the laser intensity is inhomogeneous over the field of view. The fovea is then convolved with a Gaussian filter (typically with a 3 x 3 or 5 x 5 kernel). A diffraction-limited spot covers several pixels on the camera, so this process preserves real features while diminishing pixel noise. A threshold is applied to remove residual background, and then the center of mass is calculated for the remaining pixels. The fovea for the next frame is centered on the center of mass calculated for the preceding frame. This procedure allows the software to track a single particle over many frames, even if there are multiple other particles in the large image. However, if two particles enter the fovea simultaneously, then only their mutual center of mass is tracked until one of the particles exits the fovea. The IMAQ Vision library from National Instruments performs all of the above operations in ~2.5 ms for a 32 x 32 ROI.

One of the advantages of performing feedback in software is that the feedback voltage can be an arbitrary function of the present (or past) position of the particle¹². The simplest incarnation of the ABEL trap applies a voltage linear in the offset between the particle and a target location. This is equivalent to trapping the particle in a harmonic trap. However, we have also experimented with applying voltages that correspond to power-law, double-well, and lattice potentials. Furthermore, the force field need not be the gradient of a potential: we have experimented force fields with non-zero curl, which make the particle travel in circles. The force field may also depend on the position

of the particle at times other than the most recent frame. For instance, a velocity may be calculated for the particle by calculating the displacement over the two most recent frames. Adding a force proportional to the velocity is equivalent to giving the particle momentum. Depending on the direction of this force, the apparent mass of the particle may be increased or decreased, or an effective magnetic field may be applied.

Our software also allows the user to superimpose on the feedback field an arbitrary AC or DC field. Fields with frequencies higher than the feedback bandwidth can be used to orient anisotropic particles, or to measure their mobility as a function of frequency. The ABEL trap allows one to measure time- and frequency-dependent mobilities of single particles—something which cannot be done in any other way. Time-resolved single-particle mobility measurements provide information on charge and conformational fluctuations. A DC field causes particles to sweep through the field of view. This can be useful if one is searching for a specific type of particle, or if one is working with a very dilute solution in which there are not typically any particles in the field of view.

Once a particle is trapped, there are several ways to control its position. The software accepts mouse input, so a user can simply click on an image of a trapped particle and drag the particle around on the screen. The computer adjusts the coordinates of the target position in response to movements of the mouse. Alternatively, the user may specify a file with a list of target locations. Once a particle is trapped, the computer runs through this list and applies a new target location with each frame. We have used this procedure to make particles trace out complex paths.

DISCUSSION

Optical trapping and dielectrophoresis exert very weak forces for two reasons. As is well-known, the force scales with the volume of the trapped object. Also the force arises through a second-order interaction with the electric field. Electrophoretic forces, on the other hand, are much stronger than optical forces. Electrophoresis depends on charge rather than polarizability, and is first order in the field rather than second order. This is why electrophoresis is commonly used to separate biomolecules, and optical forces are not. Electrophoresis has not previously been used to *trap* biomolecules because an electrophoretic potential contains no minima away from the boundaries. Our key innovation has been to introduce active feedback so that we make use of the strong forces produced in electrophoresis to generate a preferred position for the particle.

While the feedback *strength* is no problem for the ABEL trap, the feedback *latency* is the limiting factor. A particle can be trapped to an area of dimension $d \sim \sqrt{2Dt_r}$, where D is the diffusion coefficient of the particle and t_r is the response time of the feedback loop. We hope to develop all-hardware trapping schemes to lower t_r to < 0.5 ms (from its present value of ~ 5 ms). This will allow us to trap objects of order 1 nm in diameter.

The fundamental limit to trapping an individual fluorophore is the finite rate of photon-detection: it is impossible to know the position of a fluorophore in between photon detection events. To confine a fluorophore with $D \sim 300 \mu\text{m}^2/\text{s}$ to a distance $d \sim 1 \mu\text{m}$ requires a photon detection rate, and a feedback bandwidth, of ~ 500 Hz. We also note that, as for all single-molecule fluorescence studies,

photobleaching can limit the observation time. Future work will focus on improving the ABEL trap to the point where it can trap individual molecules in solution.

ACKNOWLEDGMENTS

AEC gratefully acknowledges a Hertz Foundation Graduate Fellowship. We acknowledge equipment purchased with partial support from the Department of Energy Grant No. DE-FG02-04ER63777.

REFERENCES

-
- ¹ K. C. Neuman and S. M. Block, "Optical trapping" *Rev. Sci. Inst.* **75**, 2767 (2004).
 - ² A. Ashkin, J. M. Dziedzic, J. E. Bjorkholm, and S. Chu, "Observation of a single-beam gradient force optical trap for dielectric particles," *Opt. Lett.* **11**, 288 (1986).
 - ³ D. G. Grier, "A revolution in optical manipulation," *Nature* **424**, 810 (2003).
 - ⁴ C. Gosse and V. Croquette, "Magnetic tweezers: micromanipulation and force measurement at the molecular level," *Biophys. J.* **82**, 3314 (2002).
 - ⁵ J. Voldman, R. A. Braff, M. Toner, M. L. Gray, M. A. Schmidt, "Holding forces of single-particle dielectrophoretic traps," *Biophys. J.* **80**, 531 (2001).
 - ⁶ H. Yang, G. Luo, P. Karnchanaphanurach, T. M. Louie, I. Rech, S. Cova, L. Xun, X. S. Xie, "Protein conformational dynamics probed by single-molecule electron transfer," *Science* **302**, 262 (2003).
 - ⁷ E. J. Peterman, S. Brasselet, and W. E. Moerner, "The Fluorescence Dynamics of Single Molecules of Green Fluorescent Protein: Effect of Mutations, pH and Matrix", *Biophys. J.* **76**, A445-A445 (1999).
 - ⁸ C. Gell, D. J. Brockwell, G. S. Beddard, S. E. Radford, A. P. Kalverda, D. A. Smith, "Accurate Use of Single Molecule Fluorescence Correlation Spectroscopy to Determine Molecular Diffusion Times," *Single Molecules* **2** 177 (2001).
 - ⁹ J. Enderlein, "Tracking of fluorescent molecules diffusing within membranes," *Appl. Phys. B*, **71** 773 (2000).
 - ¹⁰ A. J. Berglund, H. Mabuchi, "Feedback controller design for tracking a single fluorescent molecule," *Appl. Phys. B*, **78** 653 (2004).
 - ¹¹ A. E. Cohen, W. E. Moerner, "A method for trapping and manipulating nanoscale objects in solution," *Appl. Phys. Lett.* in press (2005)
 - ¹² A. E. Cohen, "Control of nanoparticles with arbitrary 2-dimensional force fields," *Phys. Rev. Lett.* (submitted).