

Frequency Doubling with Nd:YAG laser

Tony Hyun Kim, Ilan F. Almog

12/9/2008

6.161 Modern Optics Lab Project

Topics to be discussed

1. Nd:YAG laser restoration

1. Principles of operation
2. Repair of the cooling system, replacement of filter
3. Fixing the deionizer cartridge
4. Replacement of pumping lamp

2. Frequency-doubling experiment

1. Brief theory
2. Experimental setup; sources of error
3. Results and conclusion

Nd:YAG – Principles of operation

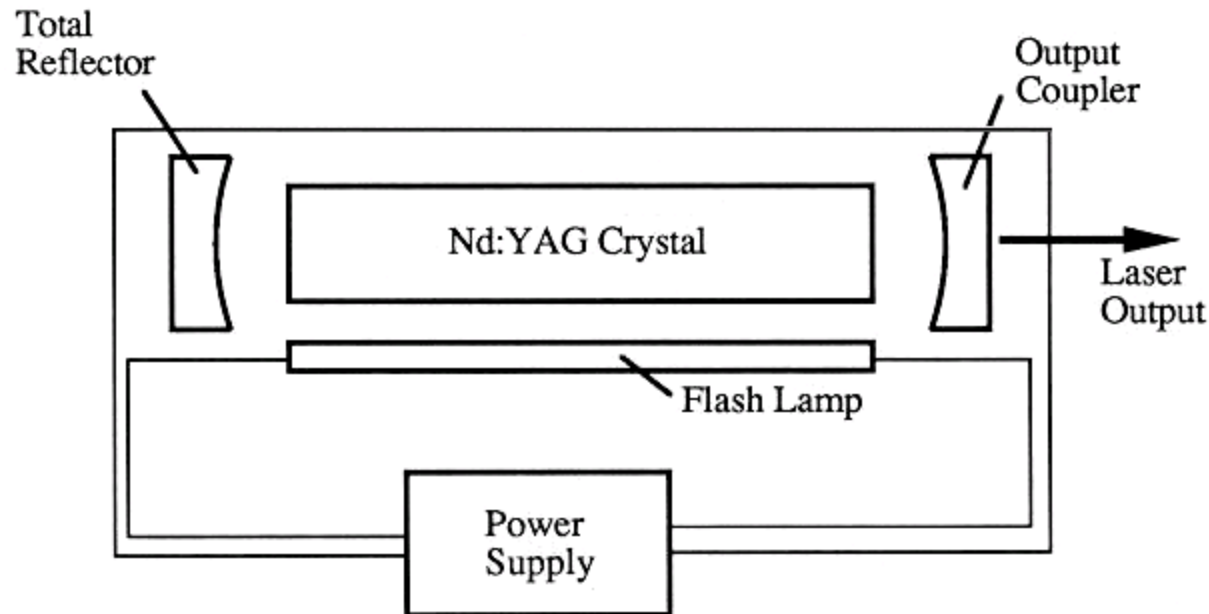

- Nd:YAG crystal has infrared (1064nm) line.
- Inversion achieved by Kr flash lamp.
- System (lamp) must be water cooled.

Our Nd:YAG, the Quantronix 116

- Insights from previous repair attempts...
- Plumbing issues:
 - Various leaks
 - Water filter too old
- Laser head:
 - Lamp malfunction

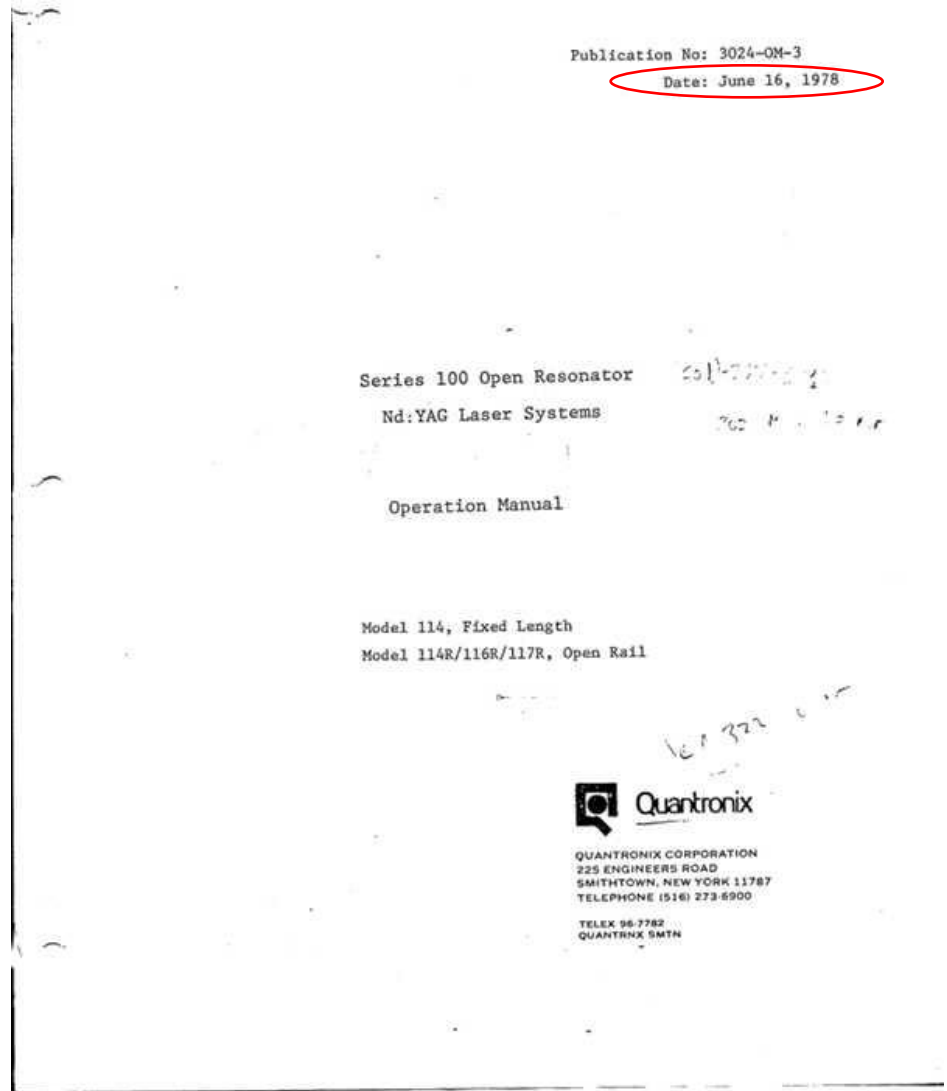

6.162: Modern Plumbing Laboratory

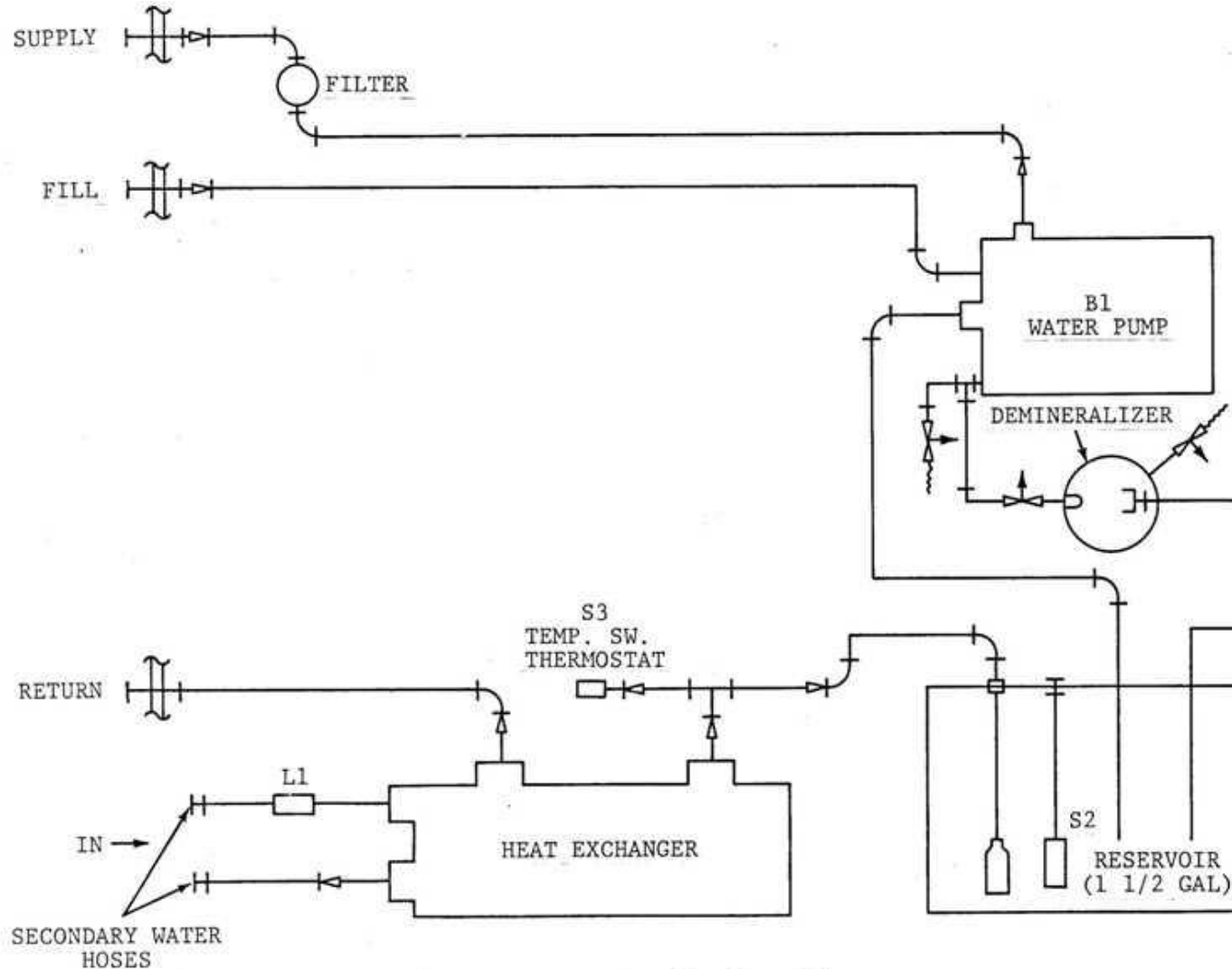
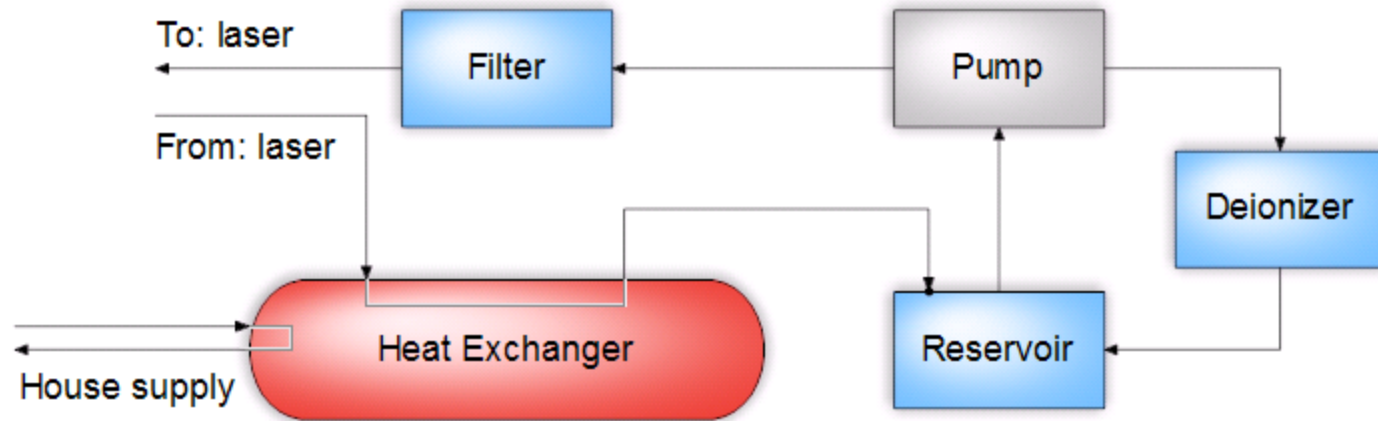

Figure 4-8. Cooling Unit, Plumbing Diagram

6.162: Modern Plumbing Laboratory



- Two system-side (water) circuits:
 - Left: Cools the laser
 - Right: Self-cleans the water supply
- Water filter was easily replaced, but...

Deionizer cartridge fiasco

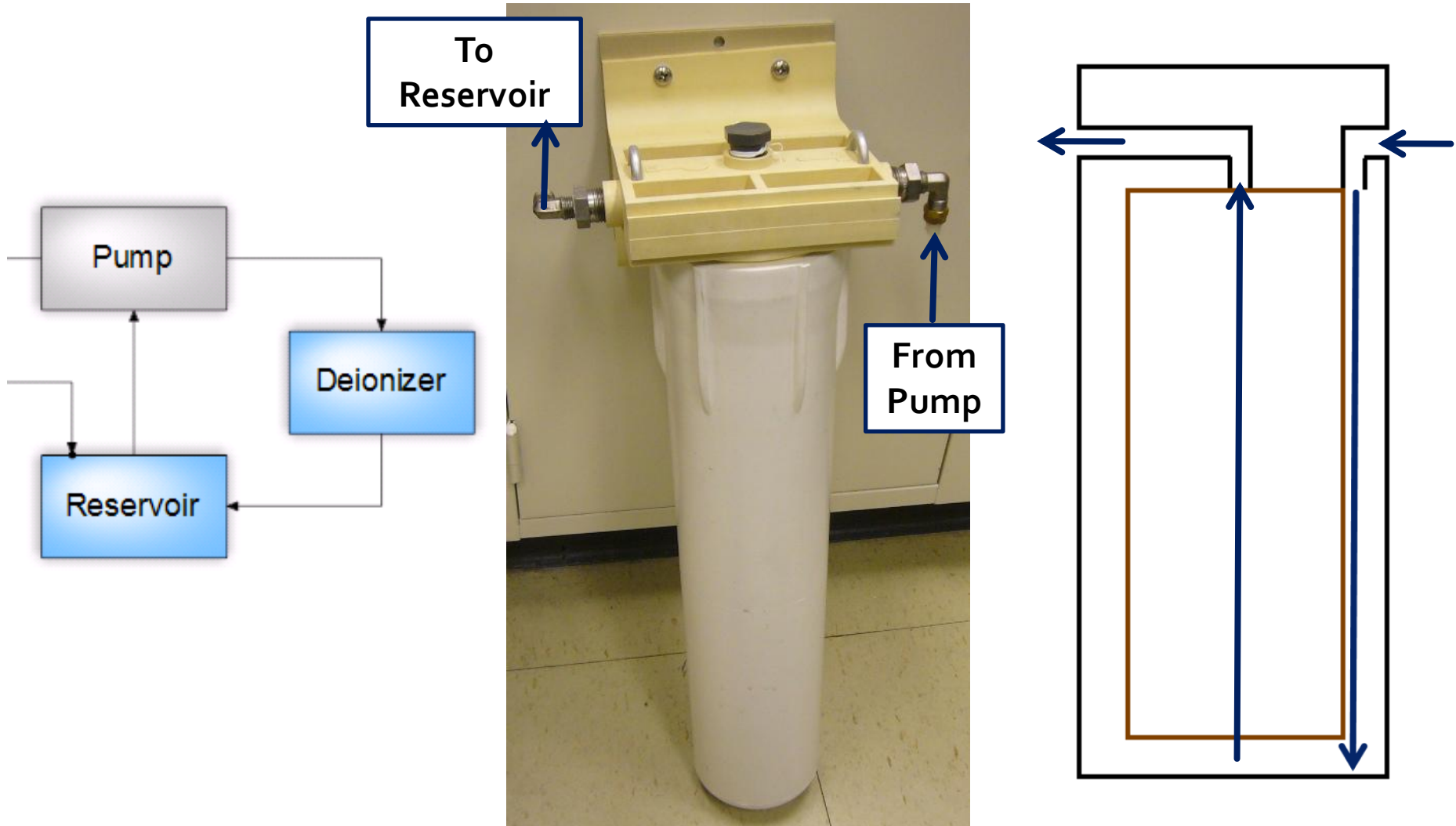

Deionizer cartridge fiasco

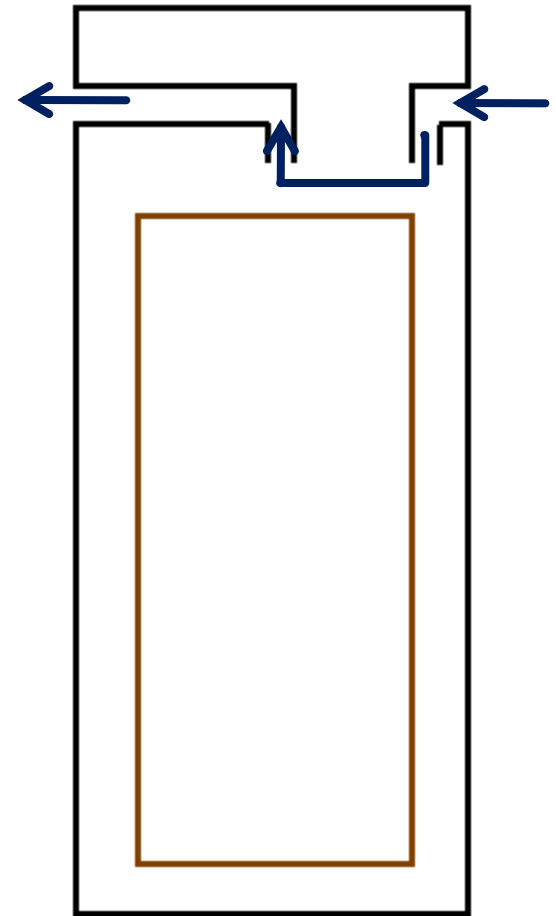

Deionizer cartridge: Solution

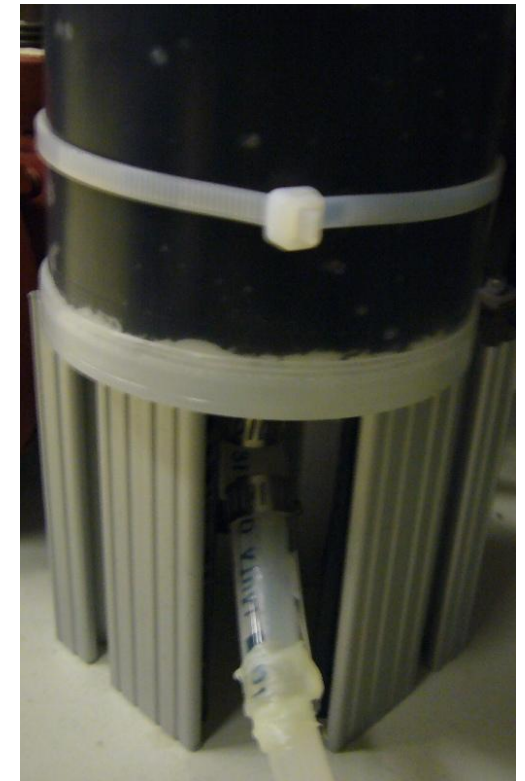

- Tubes, clamps and epoxy →
No leaks; perfect operation

Replacement of the pump lamp

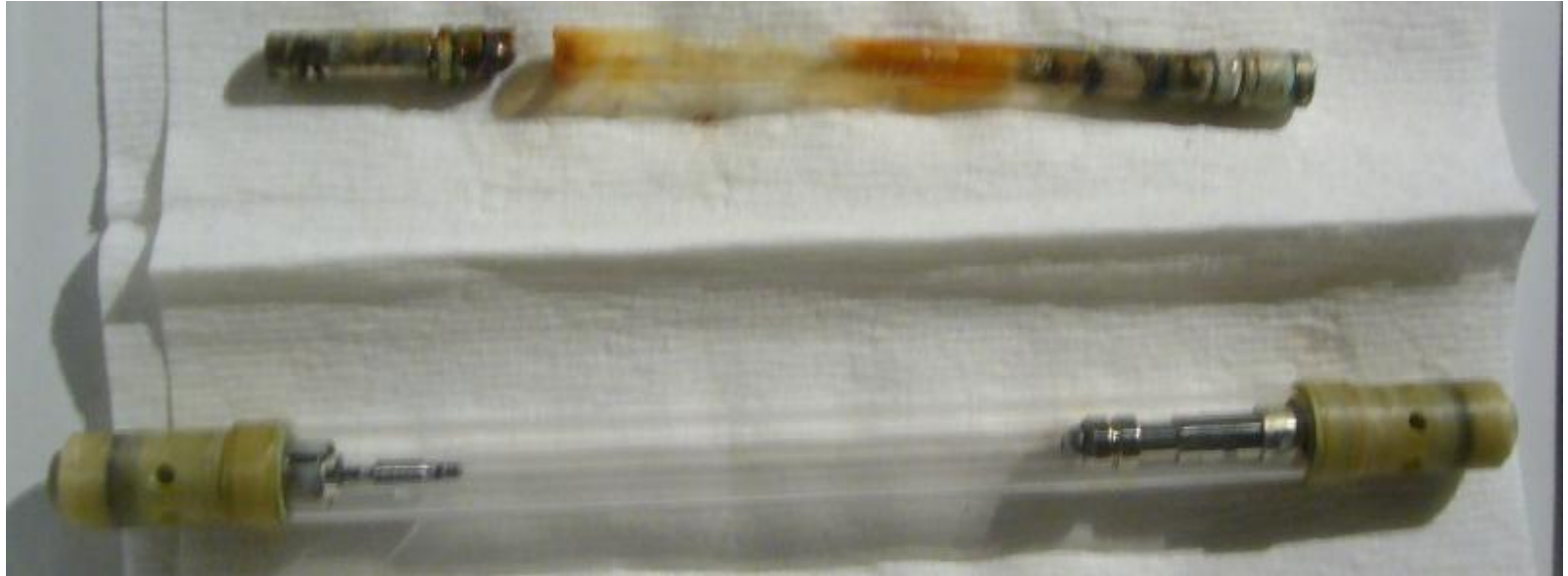

- Suspicion of malfunctioning lamp confirmed
- With plumbing and lamp fixed, laser operates!

Nd:YAG output power vs. input current

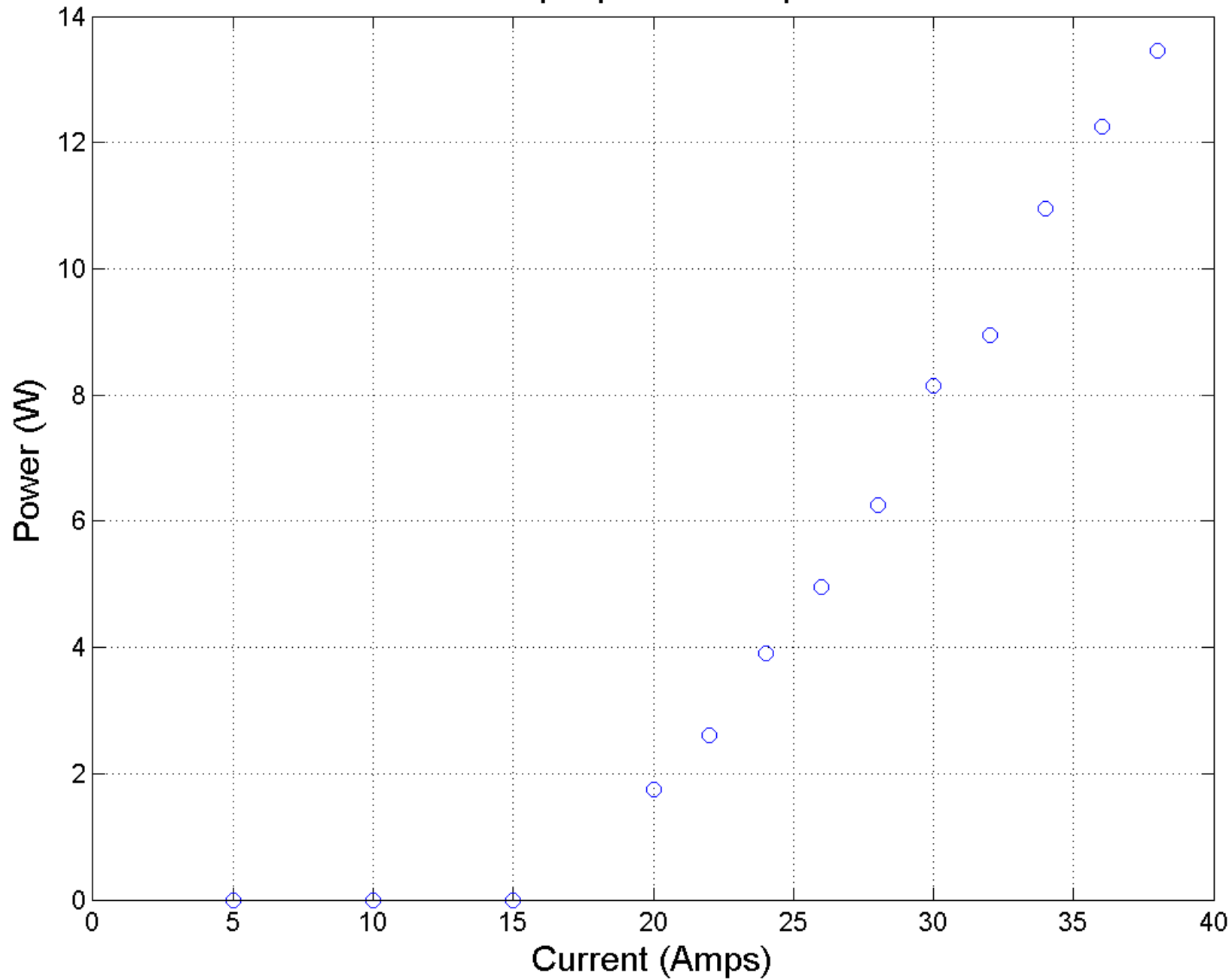

Conclusions (Nd:YAG repair)

- No known leaks.
 - Have established protocols for maintenance:
 - Refilling the reservoir.
 - Wetting the pump for initial run.
 - Pump electrical reset, and...
- Observed up to 14W of IR power



Freq. doubling introduction

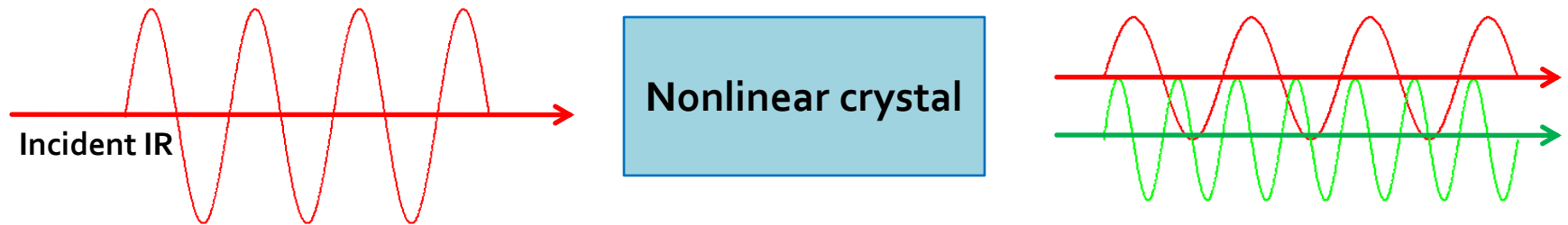

Effect of E^2 term on polarization

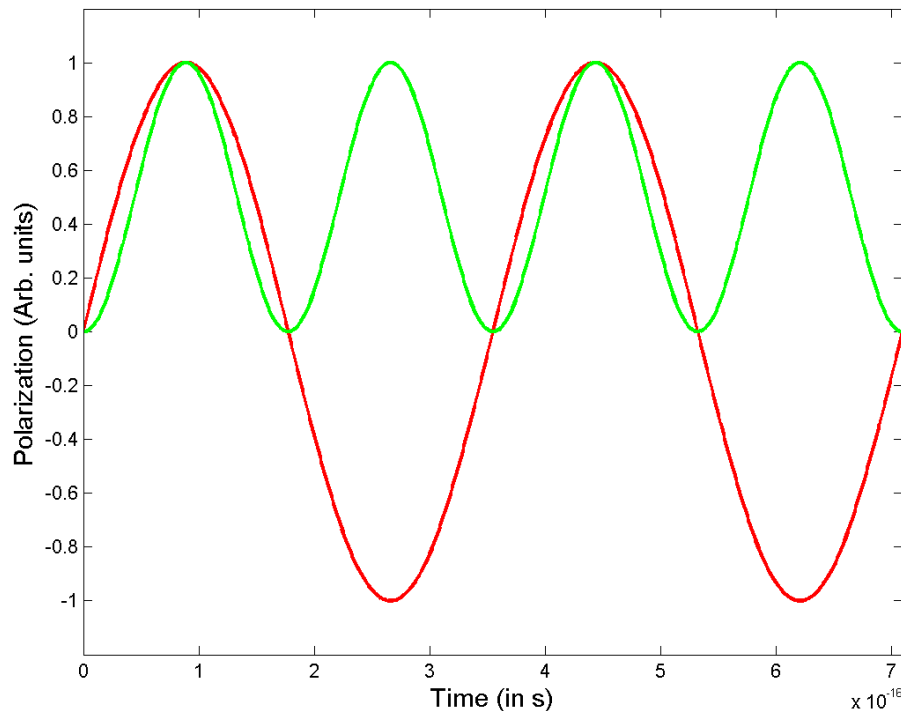

- E^2 term in polarizability (e.g. KDP crystal)
- Double 1064nm (IR) \rightarrow Obtain 532nm (green)
- Our experiment: Characterize the conversion efficiency as a function of input power.

Experimental setup

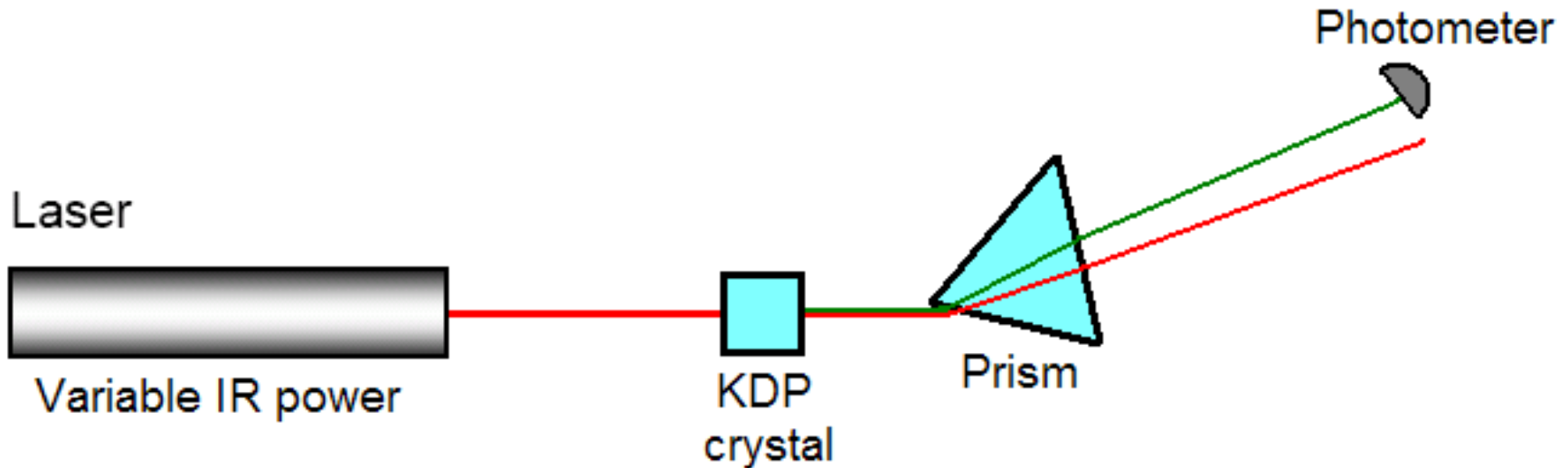

- Use dispersion of glass to achieve separation of IR (shown red) and green beams;
- Can measure power of green beam only!

Experimental setup

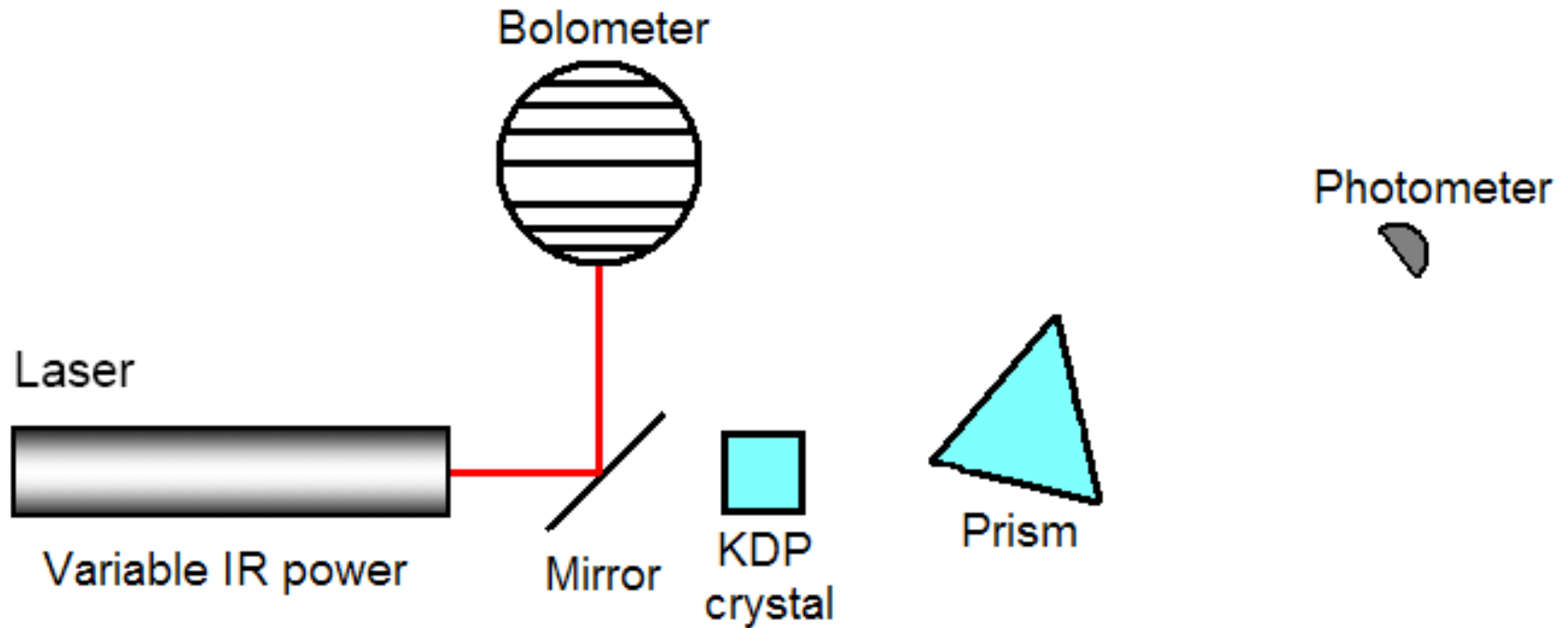

- Use pick-off mirror to measure input IR power without disturbing other optics

DANGER
HIGH VOLTAGE

COOLANT IN

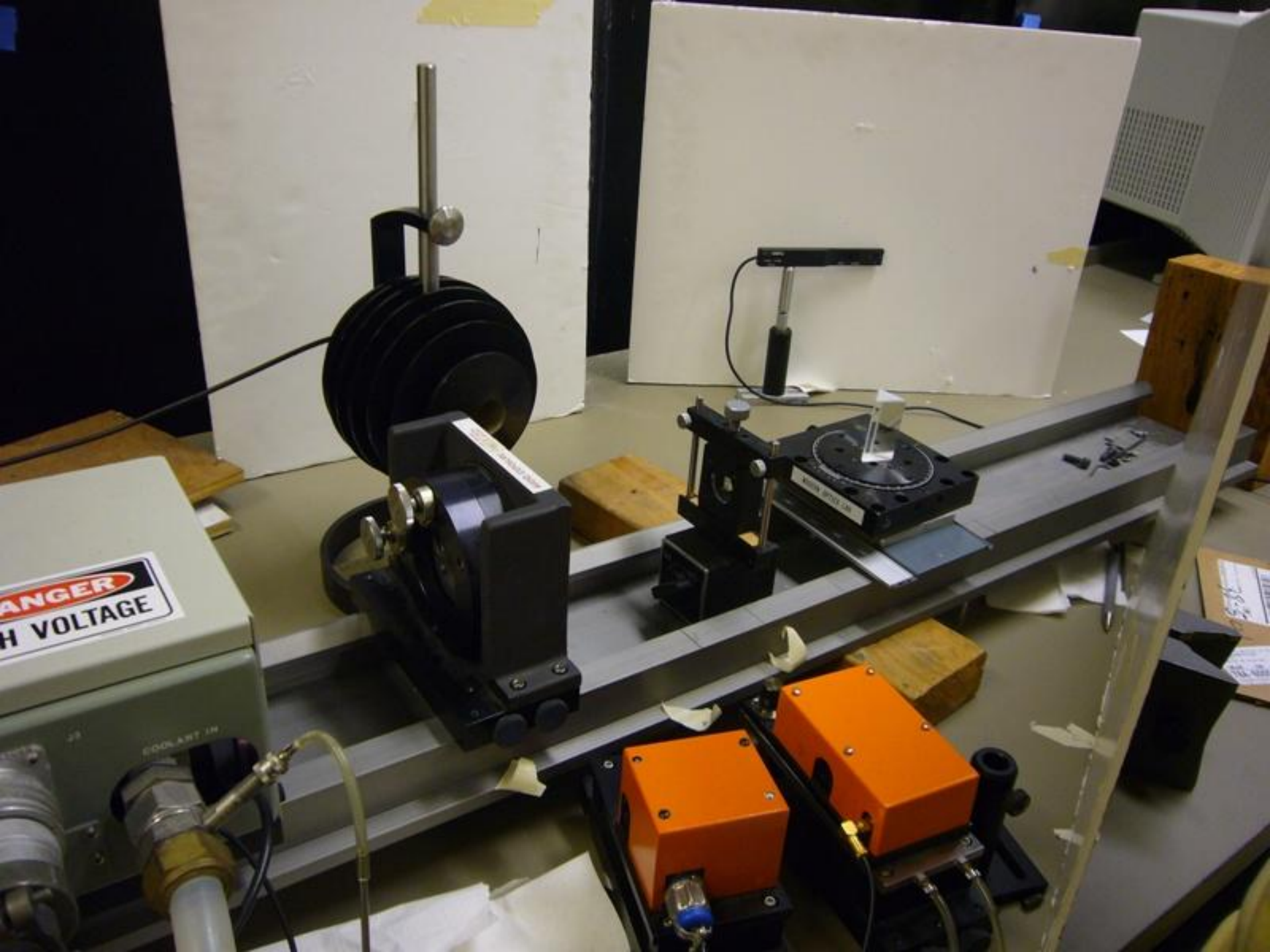

Generation of green light by freq. doubling with Quantronix 116

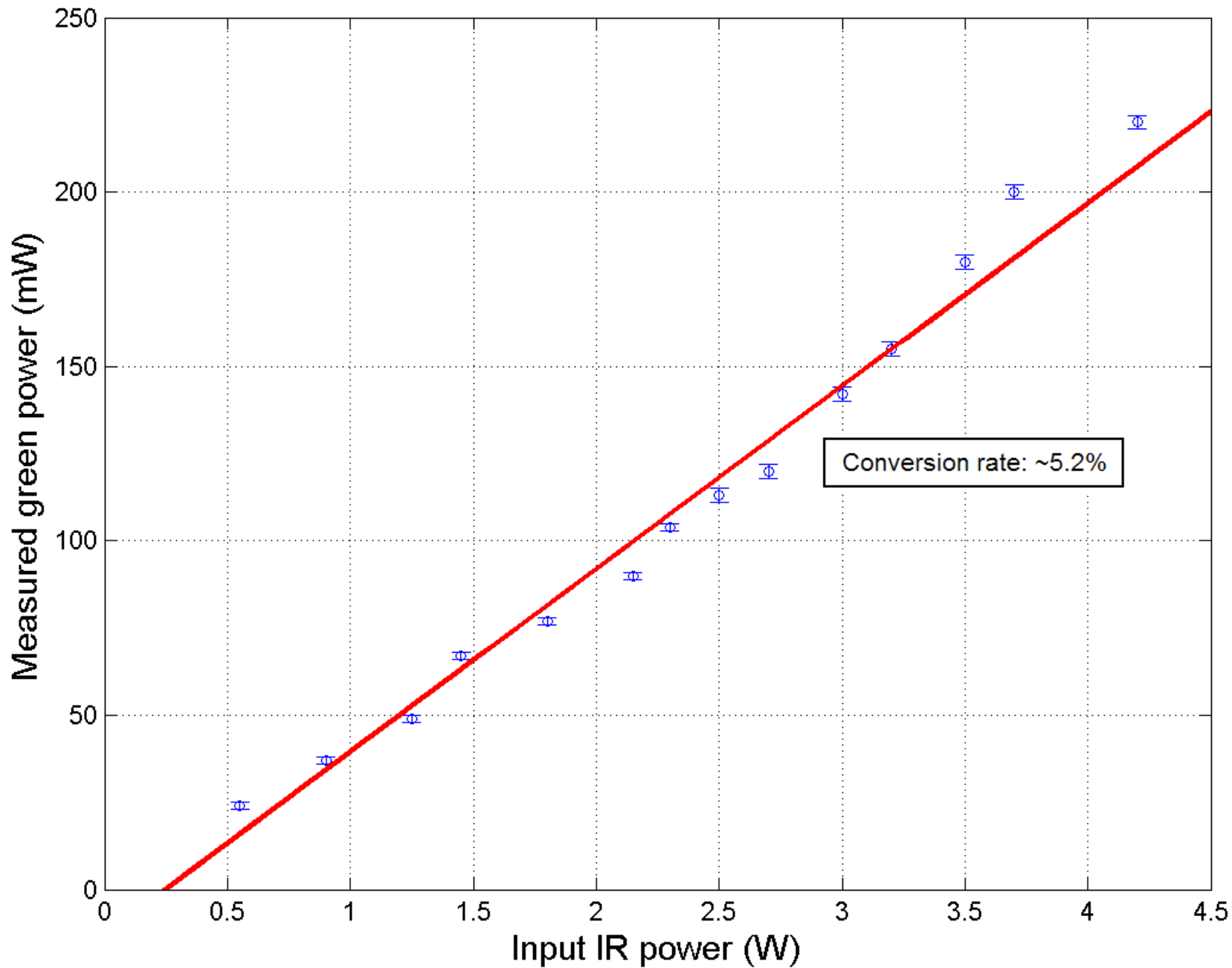

Conclusions (Freq. doubling)

- Observed frequency doubling using the newly-repaired Quantronix Nd:YAG laser.
- Based on our alignment, obtained $\sim 5.2\%$ conversion efficiency.
 - Efficiency independent of input IR power

Concluding remarks

- Showed that Nd:YAG system and KDP crystal are functional. Opens possibilities for future experiments.

Acknowledgments

- Mike the plumber;
- Dave the optics guy;
- The folks who shared the optics lab with us
 - That is: Americo, Amrita, Matt, (Raymond);
- And, of course, Bill (and Prof. Warde)



BEWARE
of DOG

BEWARE
of DOG

ESPRESSO



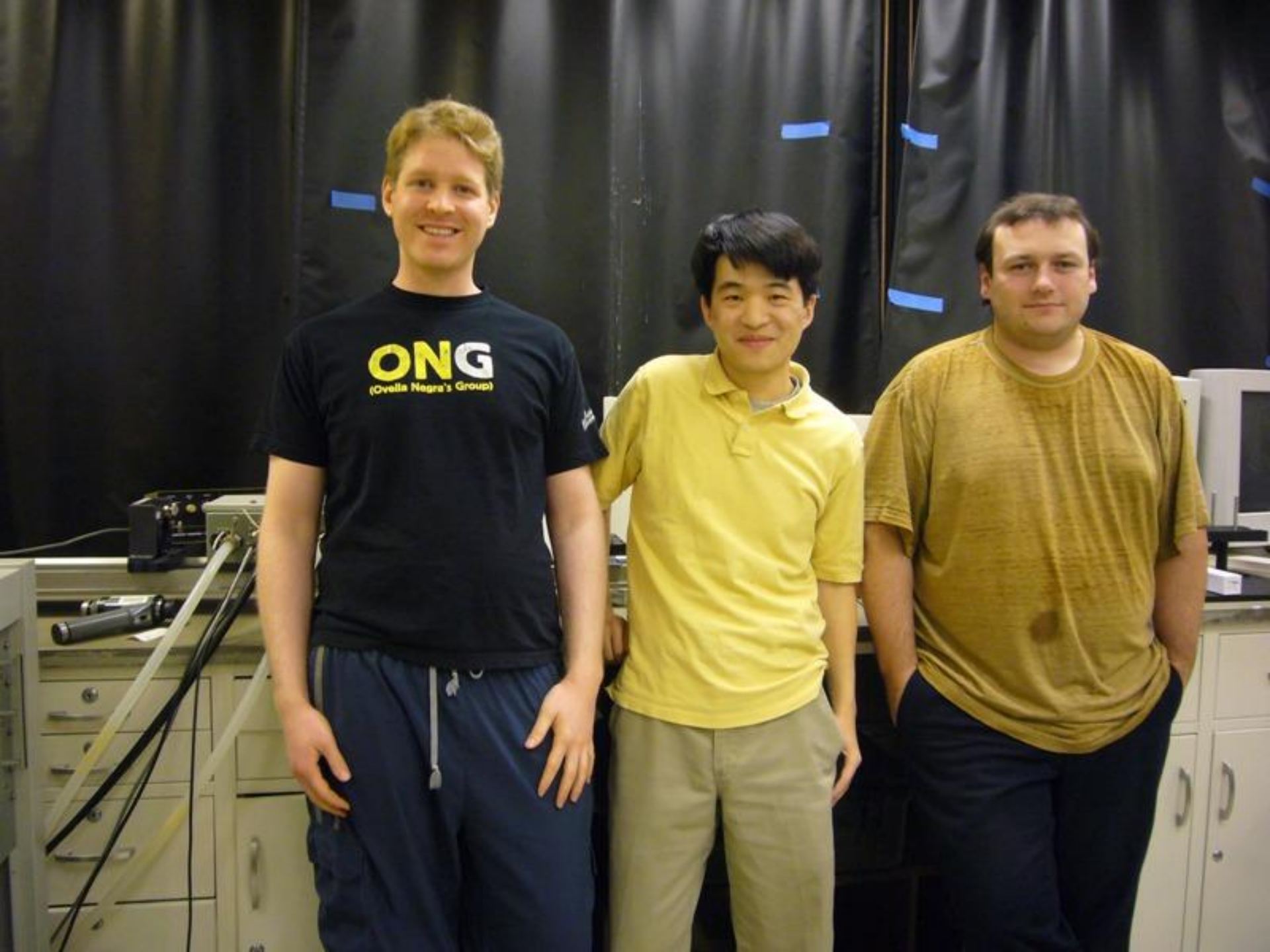

ONG
(Ovella Negra's Group)

