

6.161: Holographic Optical Element Design

Tony Hyun Kim

1 Introduction and design objectives

A hologram contains interferometric information between two light waves, such that illumination of the hologram by one of the original beams will generate the other. While the traditional application of holograms is the reconstruction of 3D images, the same principles can be used to construct objects that perform a practical optical function. In this paper, we describe the construction of such a *holographic optical element* (HOE) which has the converging properties of a lens. More precisely, our element will focus a 514nm collimated beam at a particular location off of the optical axis. See Figure 1 and specifications below. 

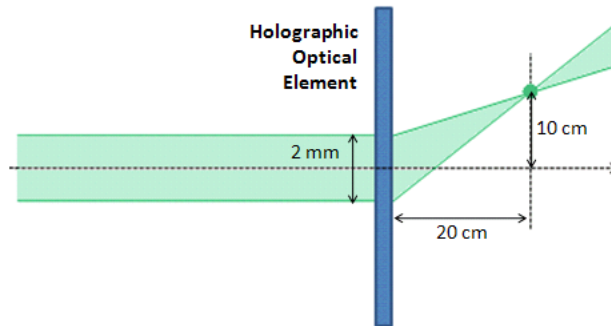

Figure 1: The HOE will focus a 2mm-wide, 514nm collimated beam. The focus is 10cm above the main axis, and 20cm from the plate.

The additional challenge in our design is that typical holographic materials are not responsive at our desired wavelength $\lambda_r = 514\text{nm}$. Hence, we must write utilize a *write wavelength* of $\lambda_w = 632.8\text{nm}$ for hologram construction, although the specified *readout wavelength* is $\lambda_r = 514\text{nm}$.

2 HOE design approach

The behavior of any hologram is completely specified by the interferometric pattern contained in the plate. Therefore, we will begin by reviewing the basic results of interferometry on a plate. The idea is to seek the necessary pattern on the HOE that is consistent with the desired specifications. We will then deduce the necessary writing geometry to mimic the required pattern, taking into account the wavelength difference in the write and read beams. Note that this final step would not be necessary if not for the additional complication of $\lambda_w \neq \lambda_r$.

3 Review of interferometry

Consider the interference of two plane waves in a planar recording material. In Fig. 2, ϕ denotes the angle between the optical axis and the “halfway”-axis of the two interfering beams; θ is the angle between the two beams. The resulting interference pattern is completely characterized by the fringe separation Λ and the fringe direction.

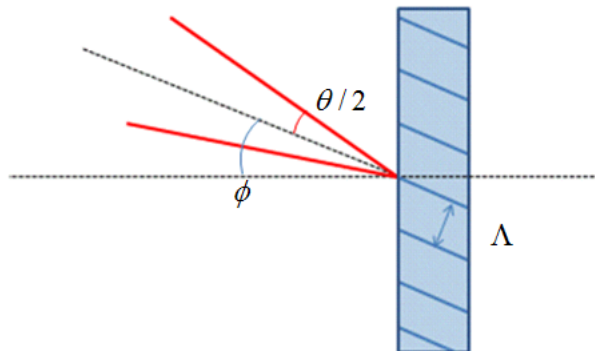

Figure 2: Illustration of interference on a plate. The two interfering beams (red) have an angular separation of θ . The “halfway”-axis of the two beams makes an angle ϕ with respect to the main axis. The fringe periodicity in the plate is given by Λ . Note also the tilt of the fringe lines.

It is clear that the fringe direction makes an angle ϕ with respect to the main axis. Likewise, it is easy to show[1] that the fringe separation in the pattern is given by $\Lambda = \lambda/(2\sin(\theta/2))$. These results can be used to yield a scheme for preserving the interferometric pattern on the hologram (and hence its function) despite our read/write wavelength mismatch.

4 Deduction of the necessary interference pattern

Suppose we were able to use the readout laser $\lambda_r = 514\text{nm}$ for hologram construction. The desired HOE could then be generated by the straightforward writing geometry shown in Figure 3, where both beams head to the right.[2] We wish to characterize the interference pattern that is written into the hologram. For simplicity, we analyze only the edges of the reference beam (points A and B), and use the plane wave approximation. Using the formulas of the previous section, we obtain the following:

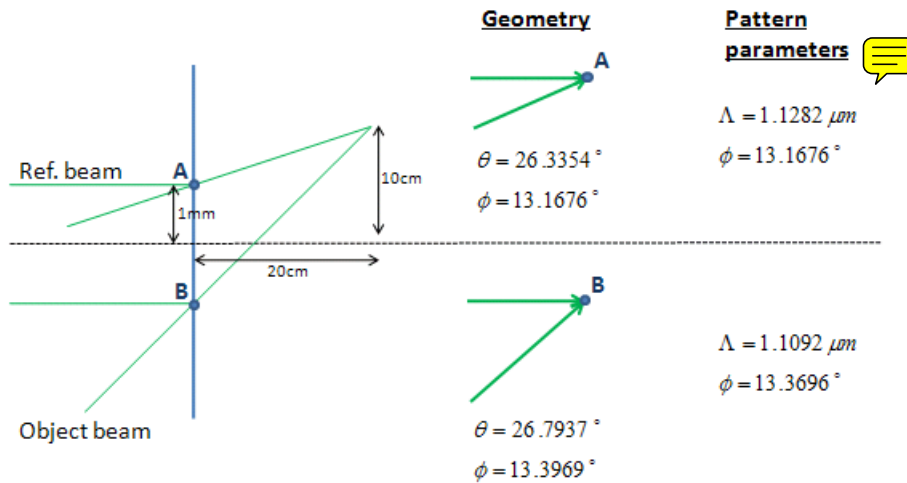

Figure 3: Characterization of the hologram interference pattern in terms of Λ and ϕ parameters. For simplicity, we analyze only the endpoints A and B, and invoke the plane wave approximation.

5 Required writing geometry for $\lambda_w = 632.8\text{nm}$

The remaining task is to deduce the necessary writing geometry for $\lambda_w = 632.8\text{nm}$ that will preserve the interference pattern. The orientation of the half-way-axis ϕ (with respect to the main axis) should obviously remain invariant, in order to preserve fringe directions. However, we must modify the angles between the beams (θ_A and θ_B), in order to compensate for the change in wavelength. Again, we use the interference equations to find: $\theta_A = 32.5746^\circ$ and $\theta_B = 33.1472^\circ$.

Since the separation of points A and B is known, the new angular data can be used to find the new writing geometry. In particular, note that the new reference

beam is slightly divergent, and the focus of the object beam has been relocated. We illustrate the final writing geometry in Figure 4.

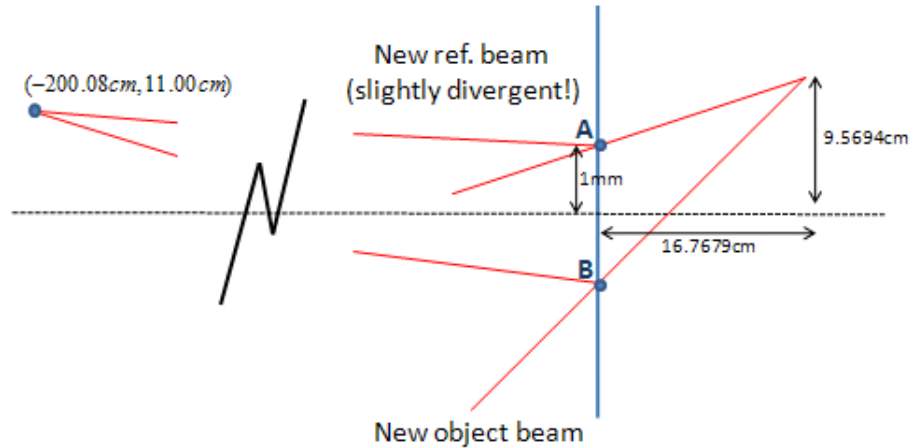

Figure 4: The final writing geometry to be used with the $\lambda_w = 632.8\text{nm}$ laser. Note that the new reference beam is slightly divergent. Its focal coordinates are given with respect to the intersection of the plate and the optical axis. The focus of the new object beam has also been shifted.

6 Conclusion

We have described the construction of a holographic optical element (HOE) that can focus a 2mm-wide, 514nm collimated beam to an off-axis focal point. The design was complicated by the need to generate the hologram with a write laser whose wavelength differs from that of the readout laser. However, our design recognized that the response of any hologram is completely specified by the interferometric pattern contained in the plate. Therefore, we were able to prescribe a modified writing geometry using the 632.8nm write laser, which would preserve the pattern of the desired HOE, and therefore also the function.

References

- [1] Cardinal Warde. *Class notes for MOL, Coherence and Interference*. (Pg 9-11).
- [2] Cardinal Warde. *Class notes for MOL, Principles of Holography*. (Pg 6-9).