

The Human Components of Image Systems

*Many of the images in this tutorial are from
Wandell, Foundations of Vision, Sinauer Press
PDF of slide presentation is at www.imageval.com*

Brian Wandell
Psychology and EE
Stanford University

Web-sites

Consulting: www.imageval.com

Research: white.stanford.edu



The Human Components of Color Systems

Color imaging systems are designed to convert optical and electrical signals into a desired perceptual effect. To design good color systems, one must understand the electronic and human components of the color-imaging pathway. This course introduces human color vision fundamentals and their influence on the design of color systems.

The course is designed for people entering the field of color engineering, or those who have worked on color technologies without the benefit of a course on human perception. The material in this course will serve as a background to various color technologies. Specifically, the student will learn about

- **Color matching** and trichromacy, the basis of the CIE color system
- **Spatial encoding** in human retina, the basis of color compression standards
- The color signals carried in the **human brain**, the basis of neurological color deficits
- **Visual adaptation** to changes in the environment, the basis of color balancing algorithms

Following this course, the student will have a better understanding of which aspects of color technology are fundamental and which are comprises necessary to ship product.

Professor Brian A. Wandell teaches at Stanford University where he founded the Image Systems Engineering Program (isep.stanford.edu). He is a co-founder of the consulting firm ImageVal (www.imageval.com) and a member of the technical advisory board of the digital pixel sensor company, Pixim (www.pixim.com). He is also a member of the Stanford Neurosciences Program where he teaches about the visual pathways and neuroimaging. He is the author of a textbook on human vision (Foundations of Vision, www.sinauer.com).

Tutorial Outline

- Introduction: Appearance and Computation
- Wavelength encoding and the photoreceptors
- Spatiotemporal sensitivity and the retina
- Color coding and visual cortex
- Visual Adaptation

Turning the Tables

(R.N. Shepard)

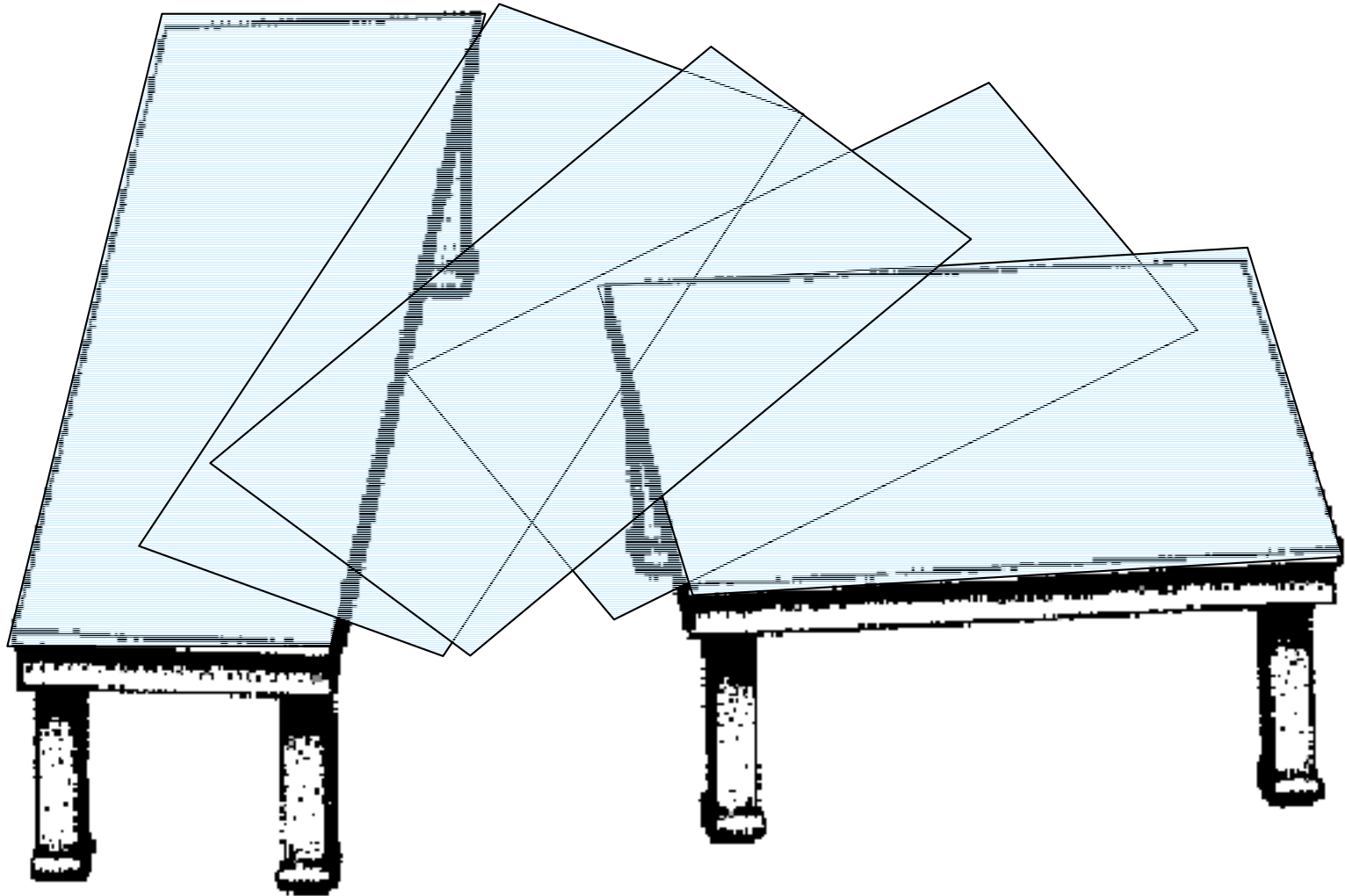

Fraser's Spiral

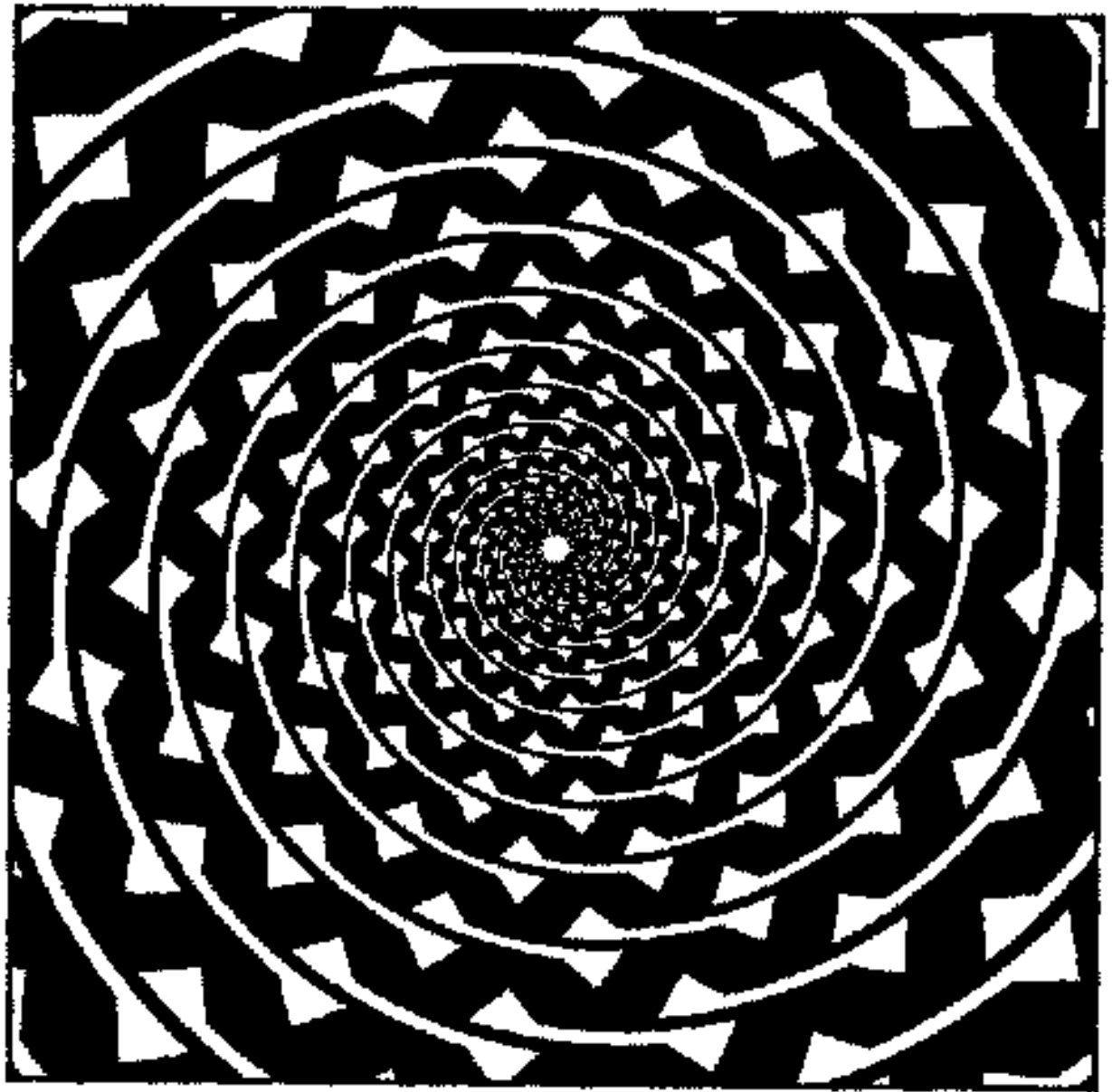

The Perception of Lightness

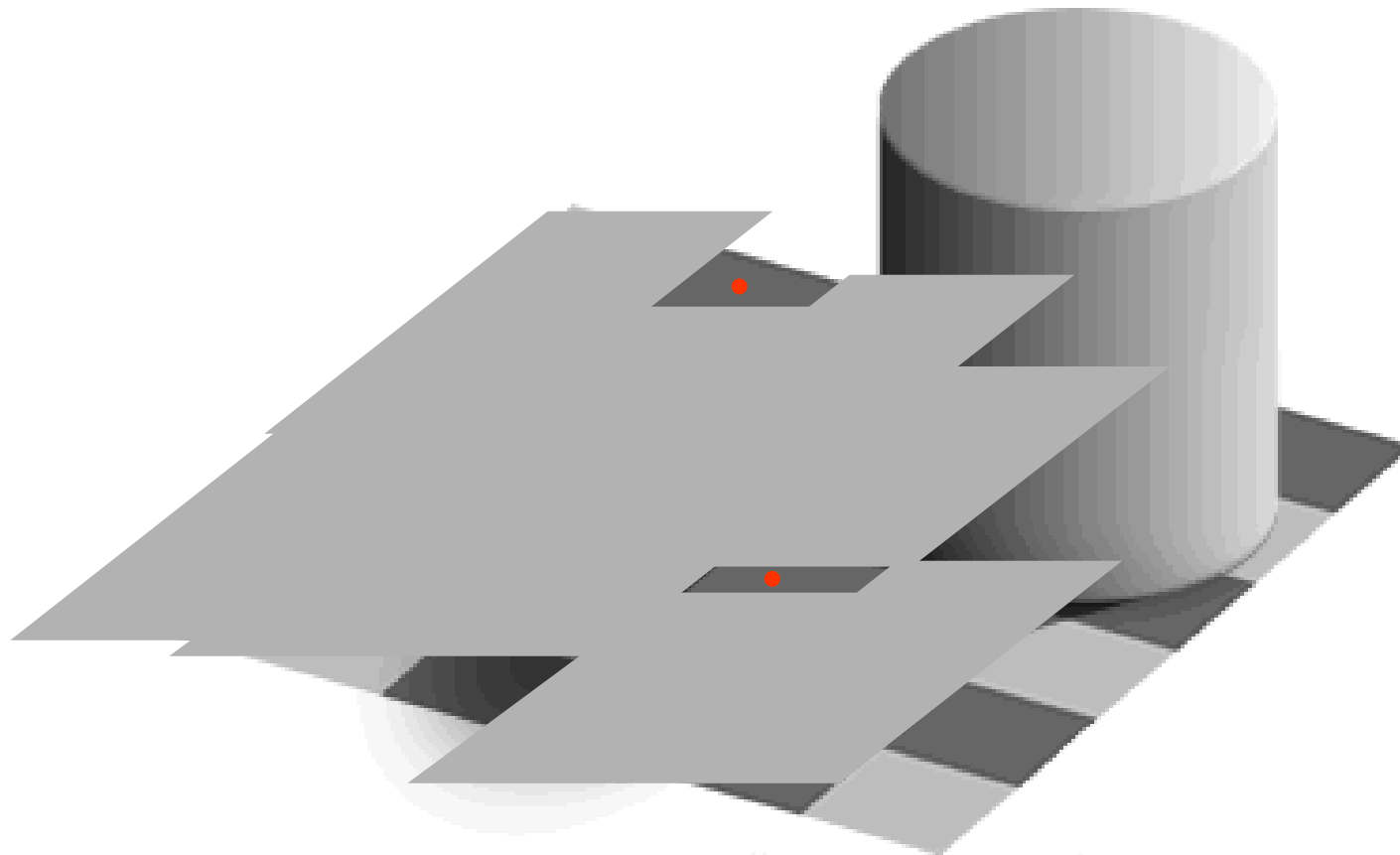

Apparent Lightness Illusion

Craik-O'Brien-Cornsweet Effect

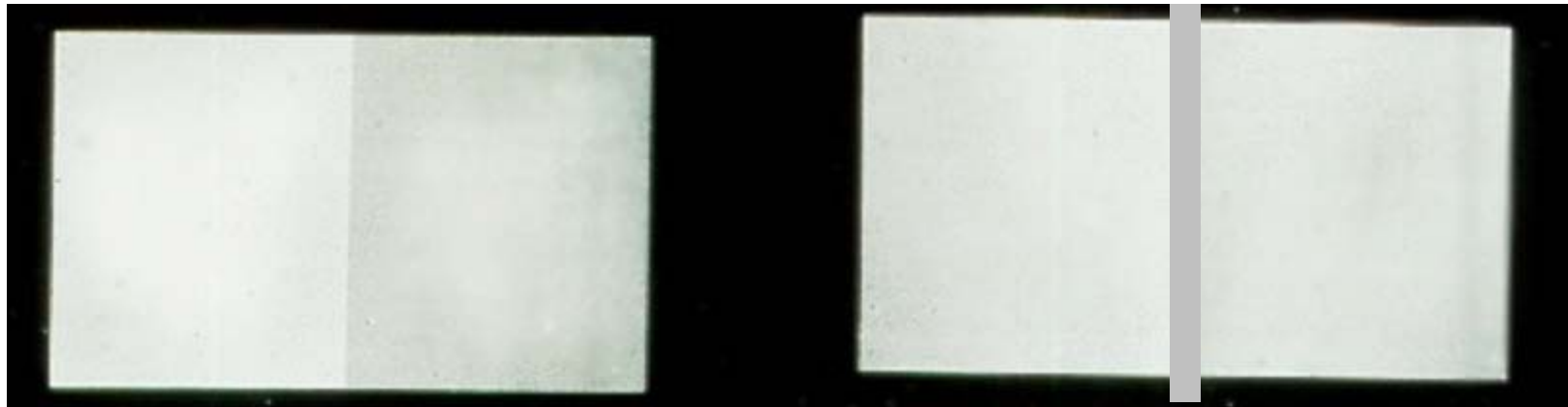

Intensity



Position

Color Matching Is An Important Illusion That Is Understood Quantitatively

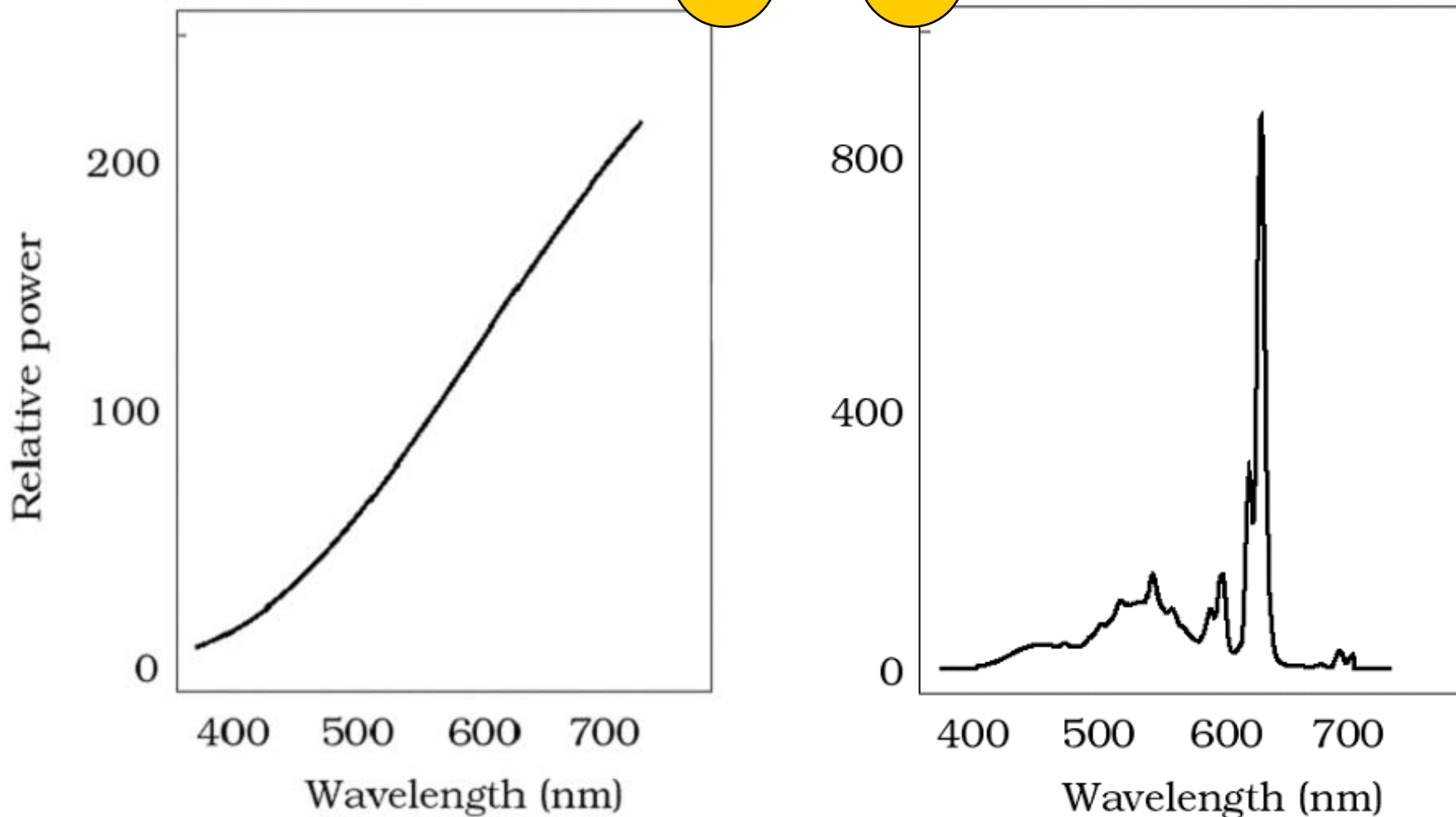

The Retina Has Three Layers And Five Basic Cell Types

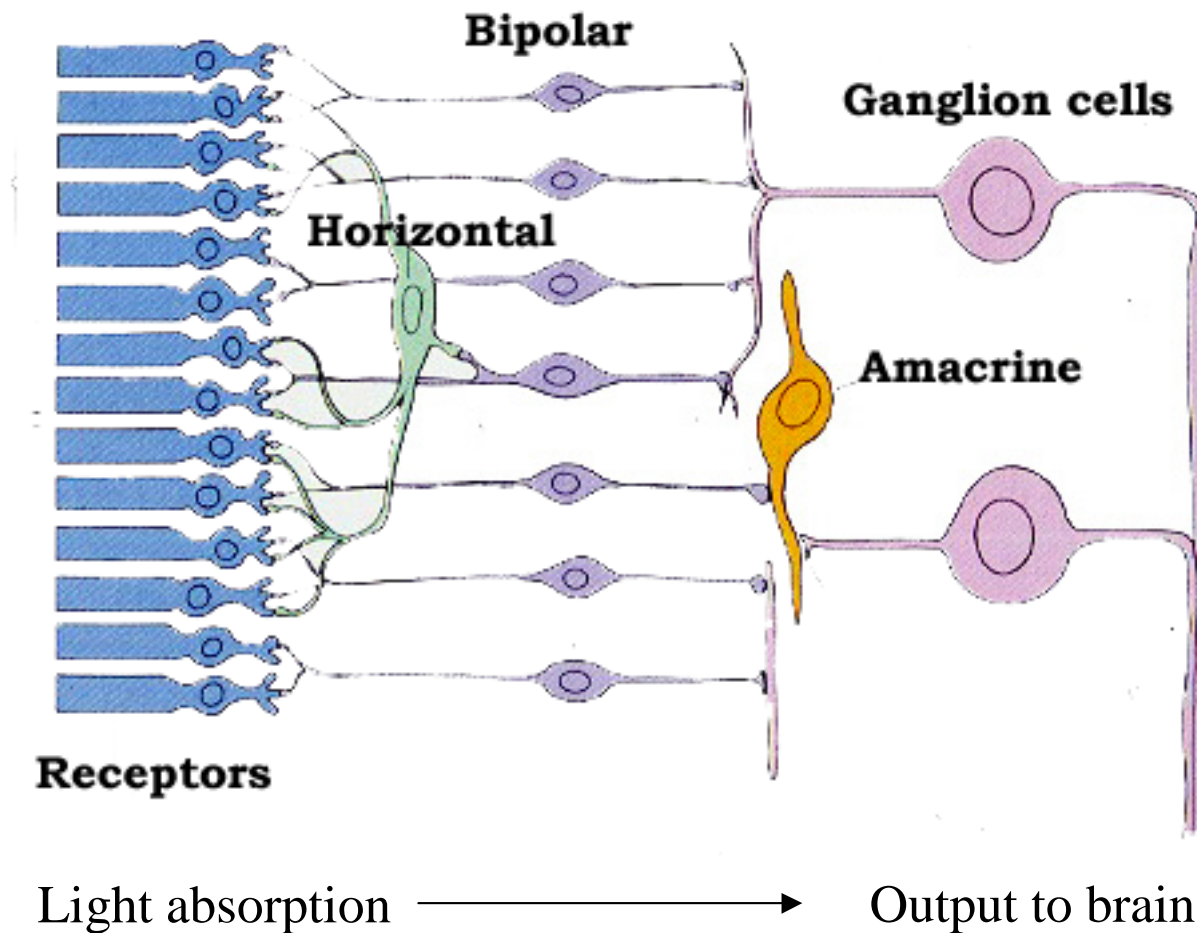

There are Three Types of Cones Containing Different Photopigments

(Young, 1802)

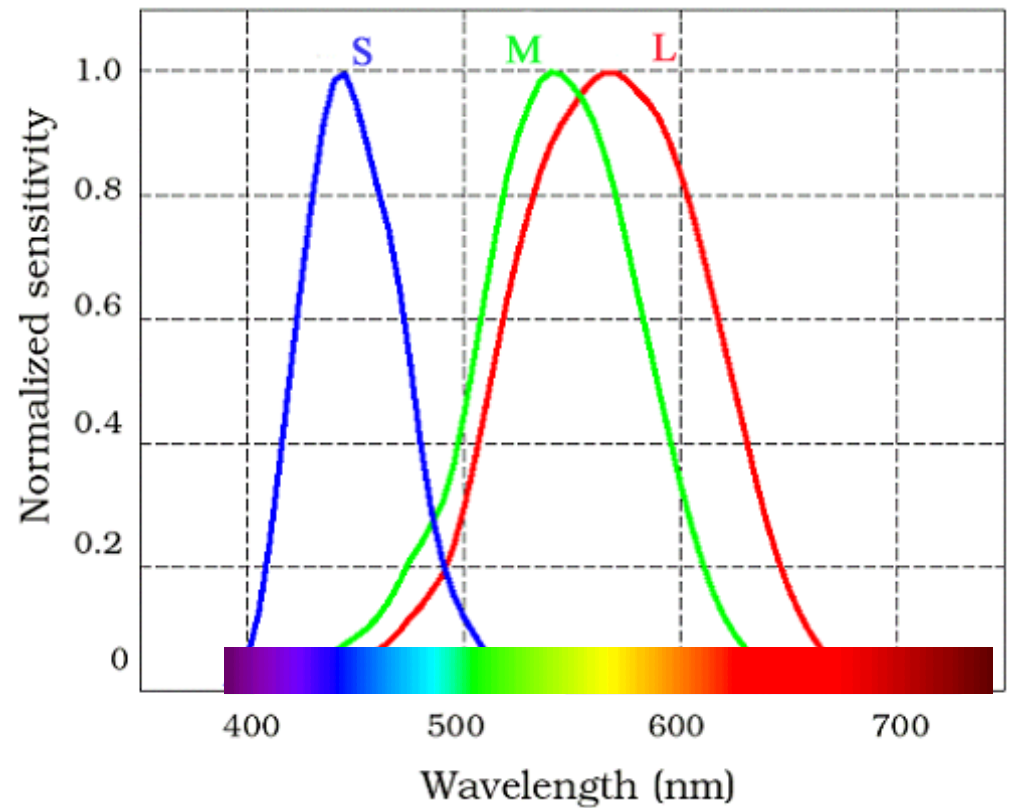
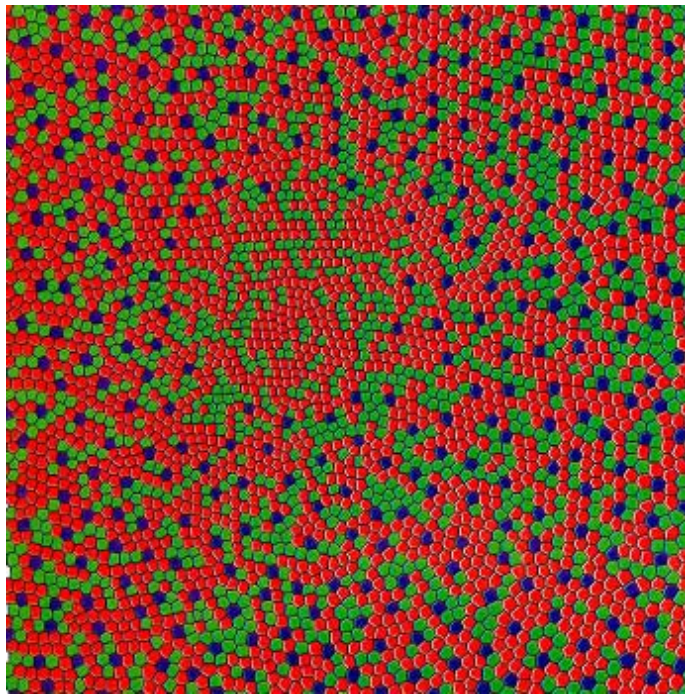

A General Characterization of Cones By Color Matching

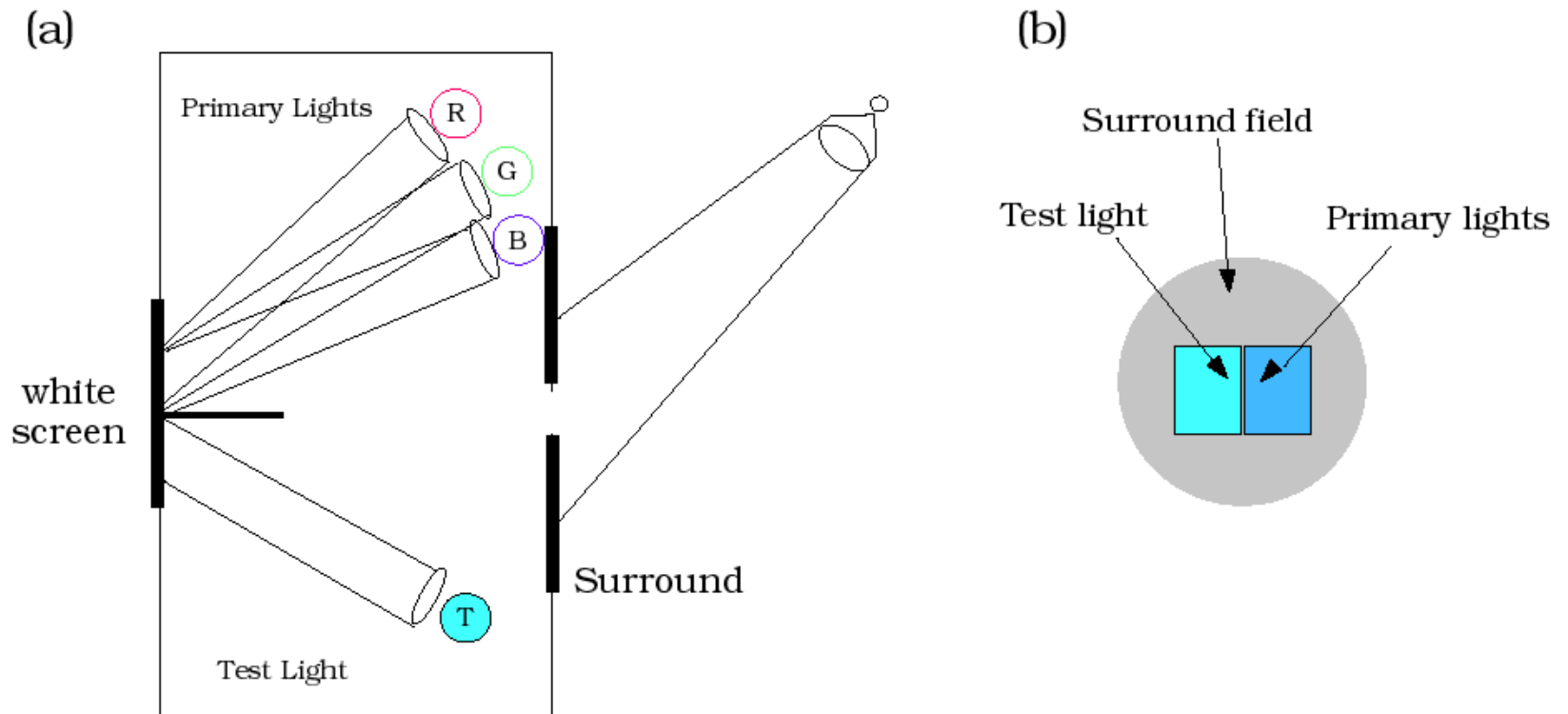

The Color Matching Experiment Is Linear

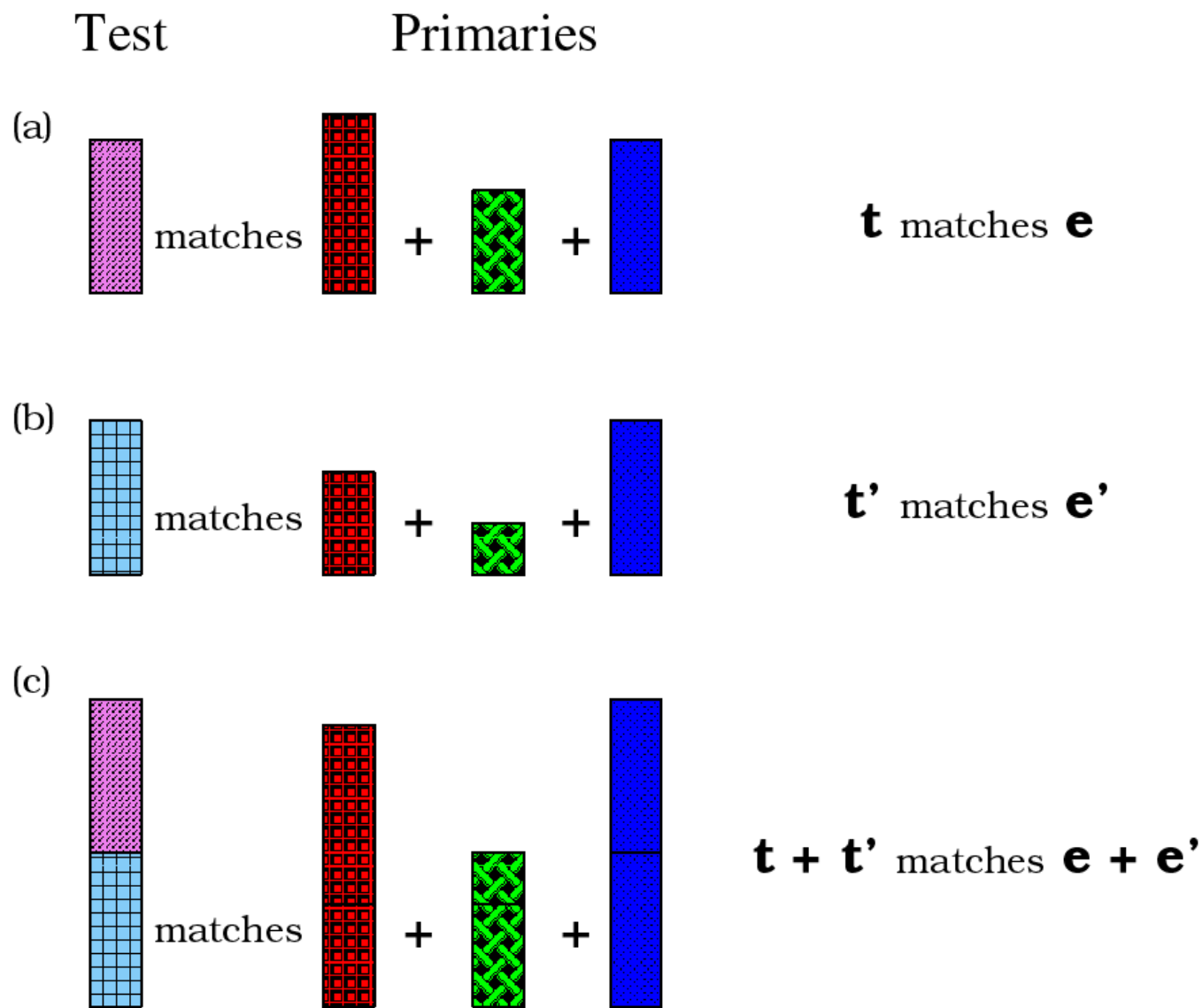

The Color Matching Experiment Is Linear

If

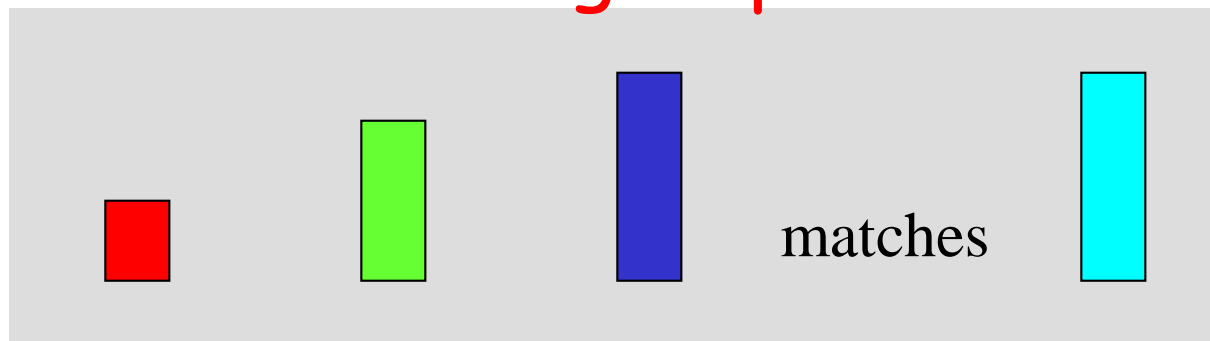

and

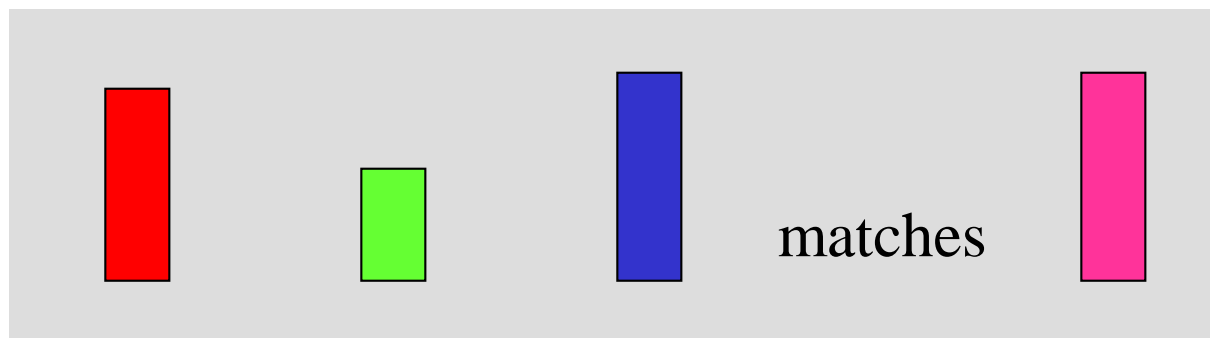

then

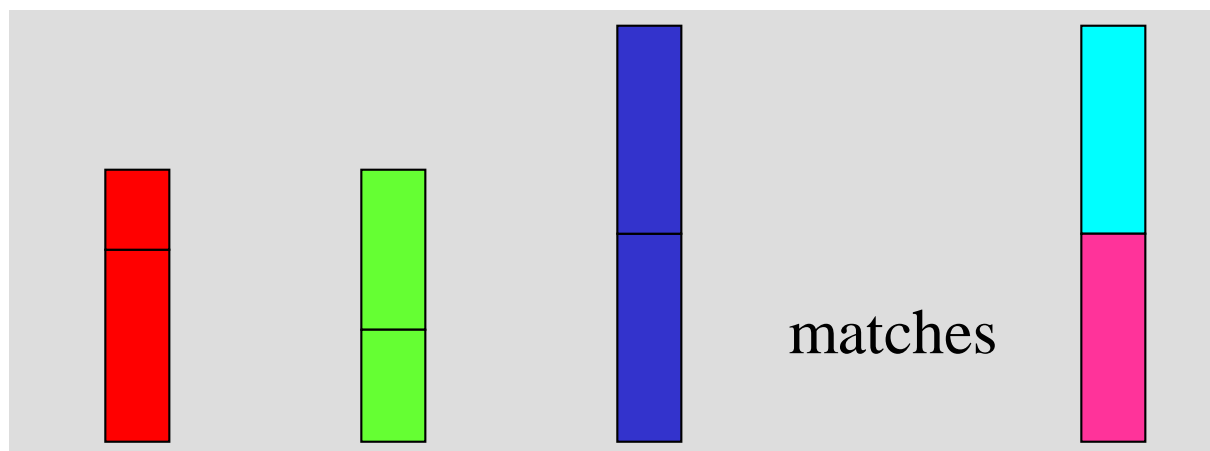

The Color Matching Measurements are the CMFs (10 deg shown)

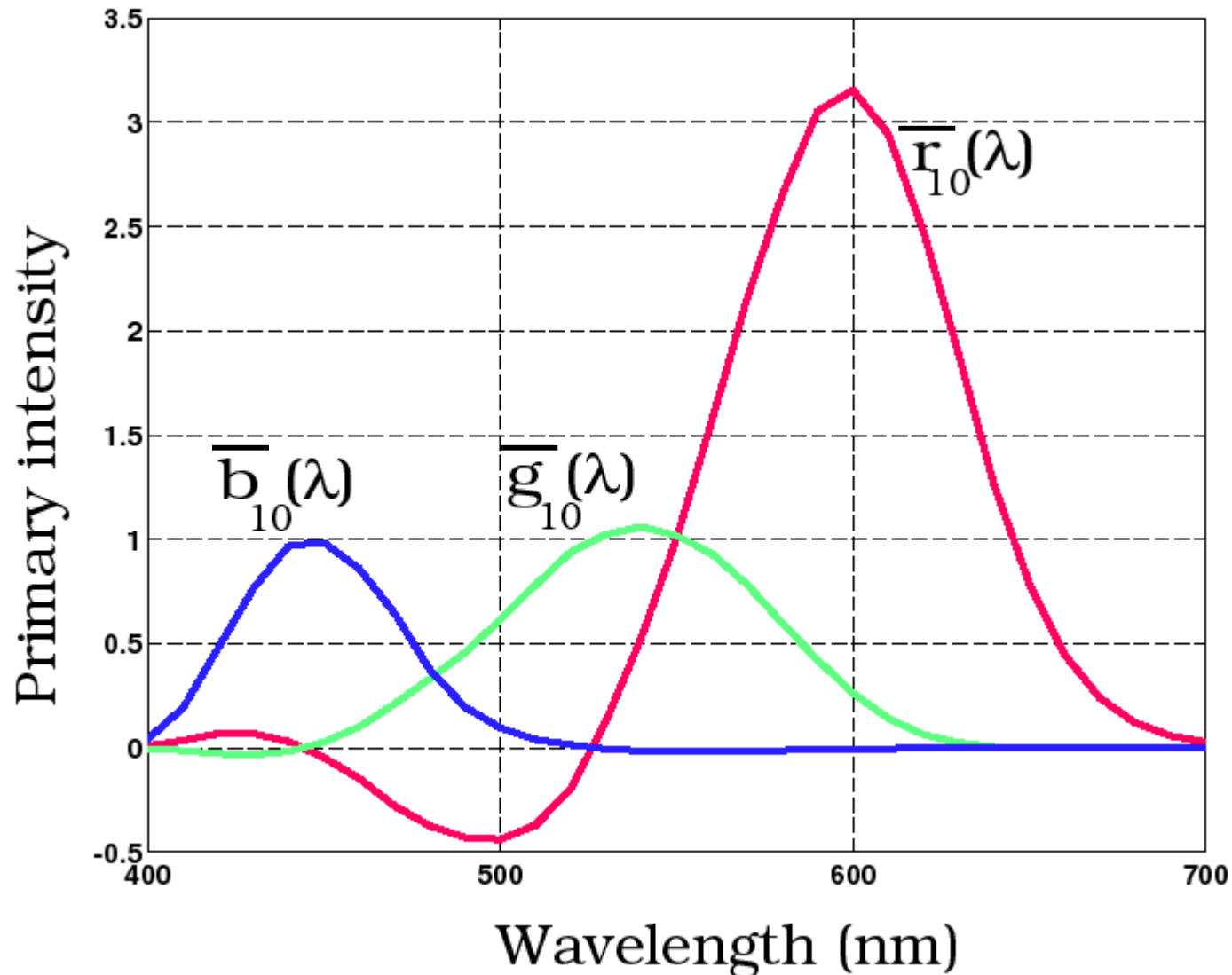

Color Matching Is Efficiently Summarized by 3 Linear Equations

Response

CIE RGB functions

Input SPD

$$\begin{pmatrix} R \\ G \\ B \end{pmatrix} = \begin{pmatrix} \text{---} \\ \text{---} \\ \text{---} \end{pmatrix} t$$

$$r=Rt$$

Color Matching Is Efficiently Summarized by 3 Linear Equations

(for people who prefer integrals to matrices)

$$R = \int \bar{r}(\lambda)t(\lambda)d\lambda$$

$$G = \int \bar{g}(\lambda)t(\lambda)d\lambda$$

$$B = \int \bar{b}(\lambda)t(\lambda)d\lambda$$

The Wavelength Response Selectivity of the Three Cone Types Has Been Measured

(Schnapf, Nunn, Baylor)

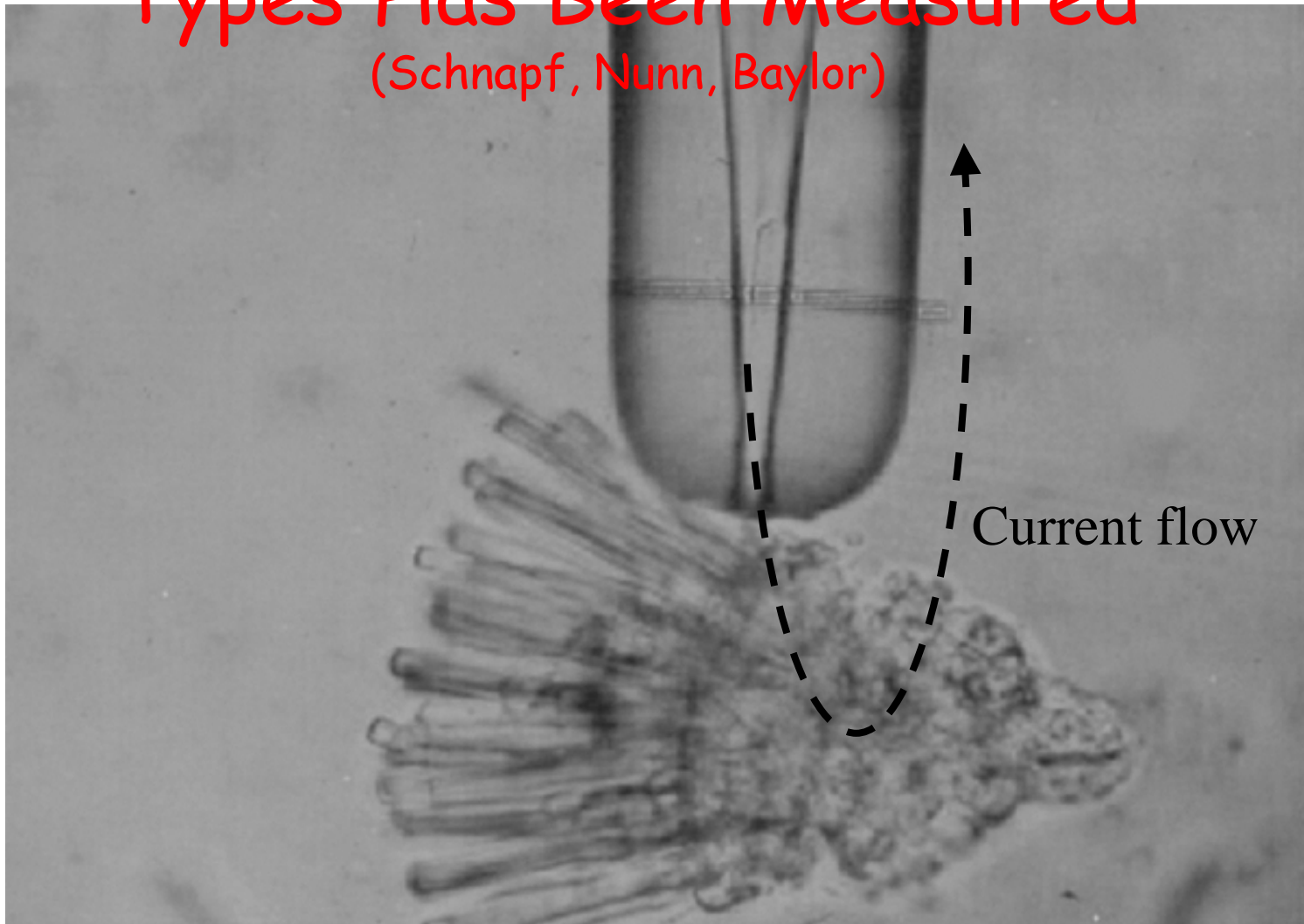

Cone Photocurrent Wavelength Sensitivity (Without The Optics)

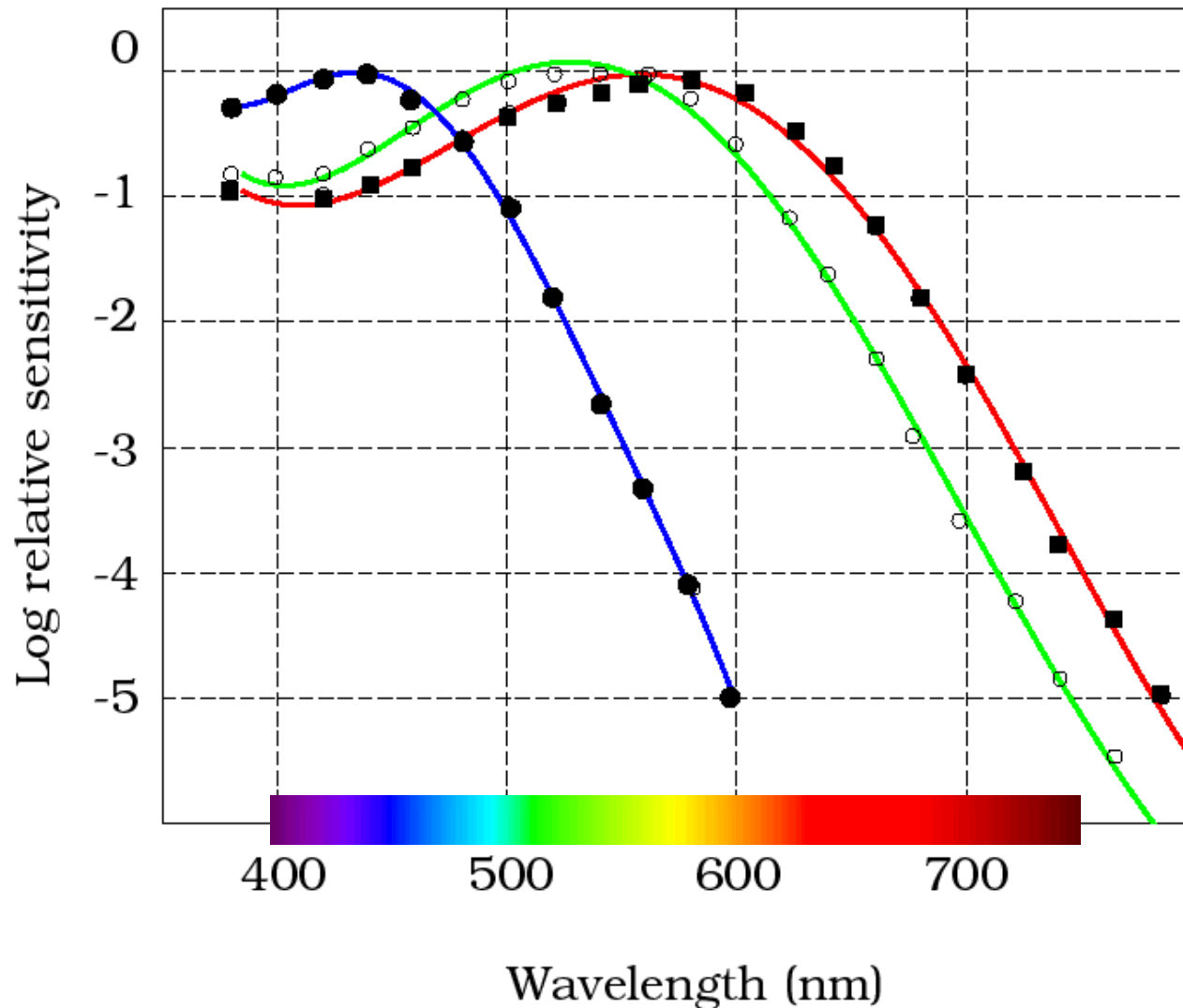

Stimuli Causing Equal Cone Absorptions Match Perceptually

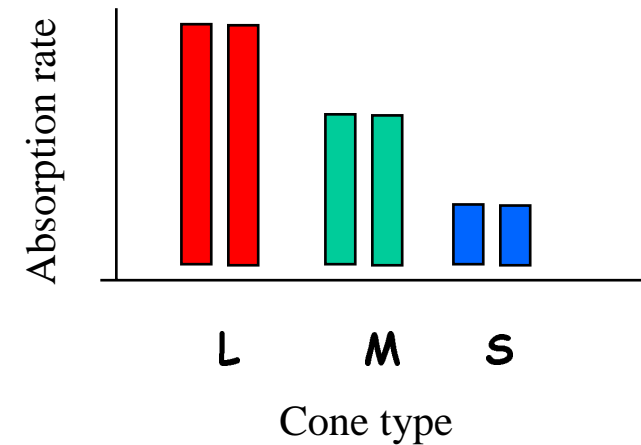
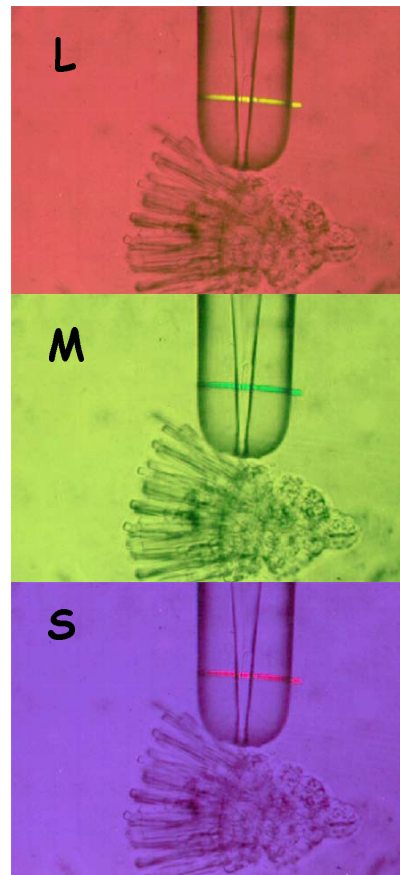
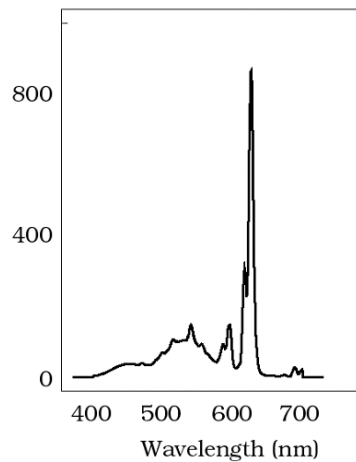
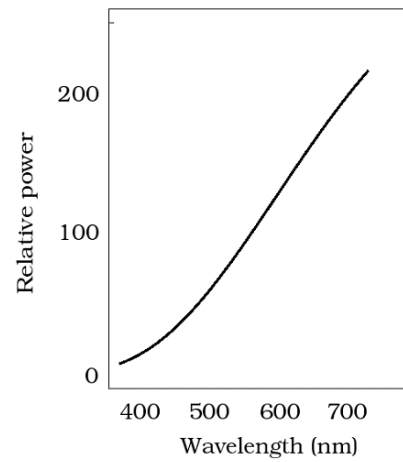

Cone Responsivity Predicts The CMFs Measured Behaviorally

(Schnapf, Nunn, Baylor)

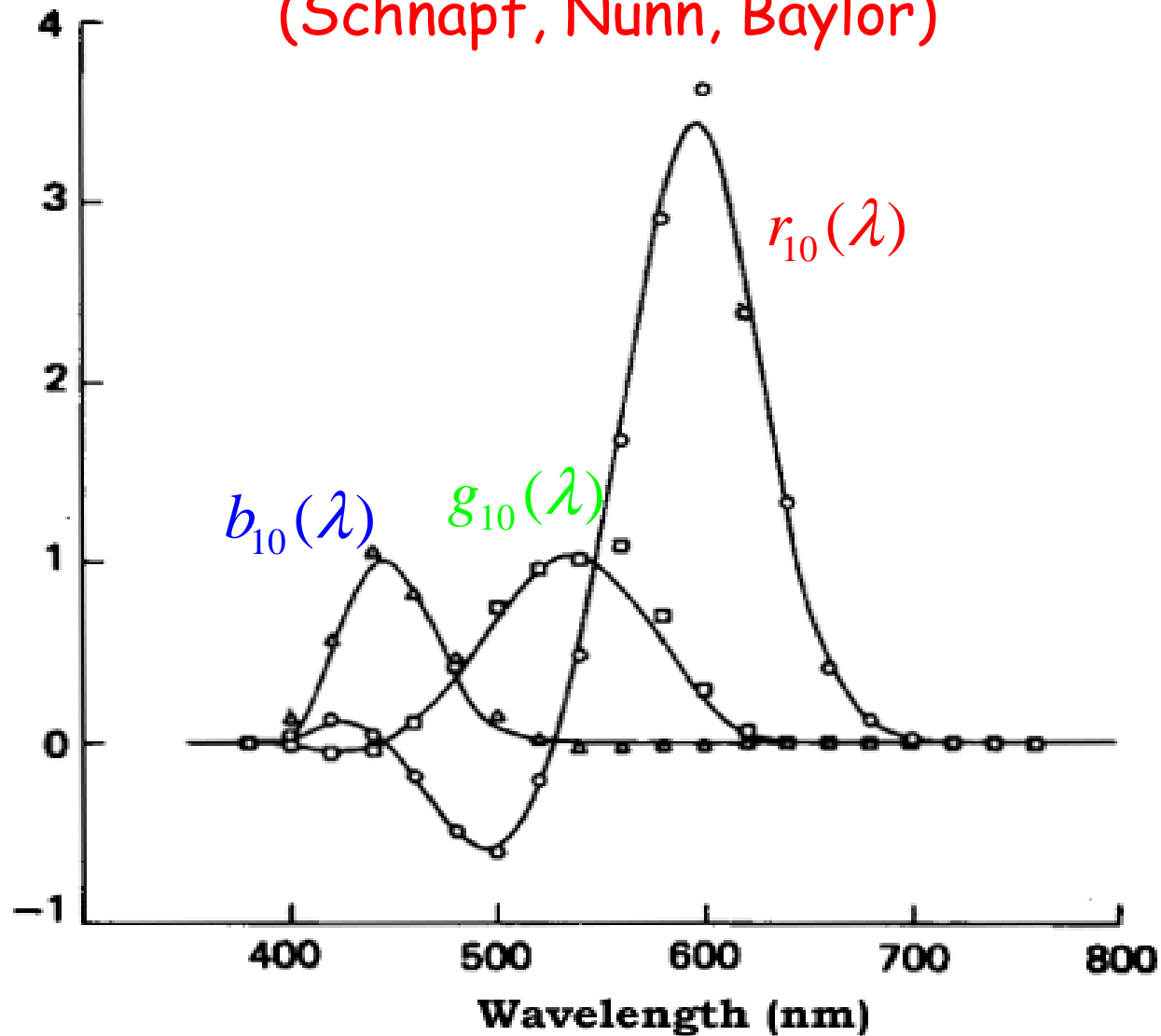

The Matching Illusion Can Be Predicted From The CMFs or the Cones

Wandell, CIC 2002

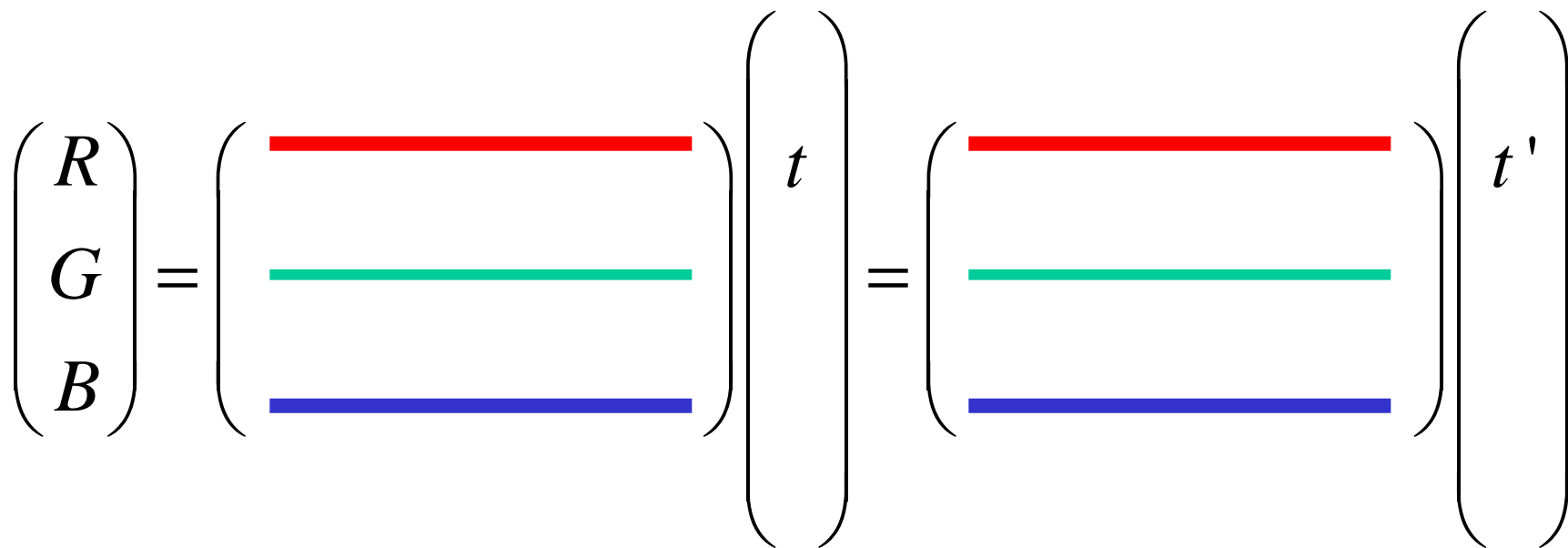

$r = Rt = Rt'$ -- t and t' are called **metamers**

Matching Is Not The Same As Appearance

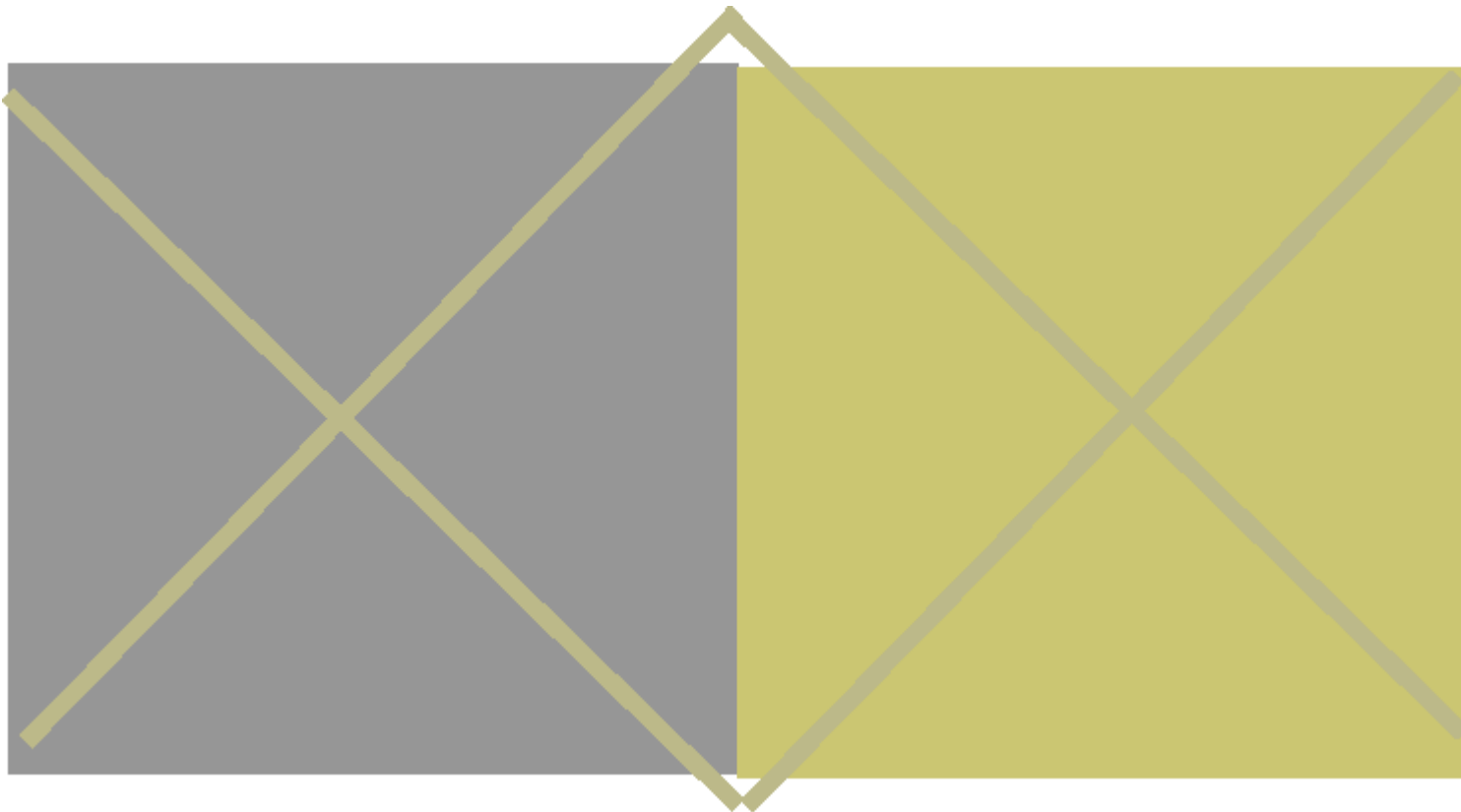

After Albers

Color Appearance Depends On The Spatial Pattern Across The Cone

Mosaic

(Shevell and Monnier)

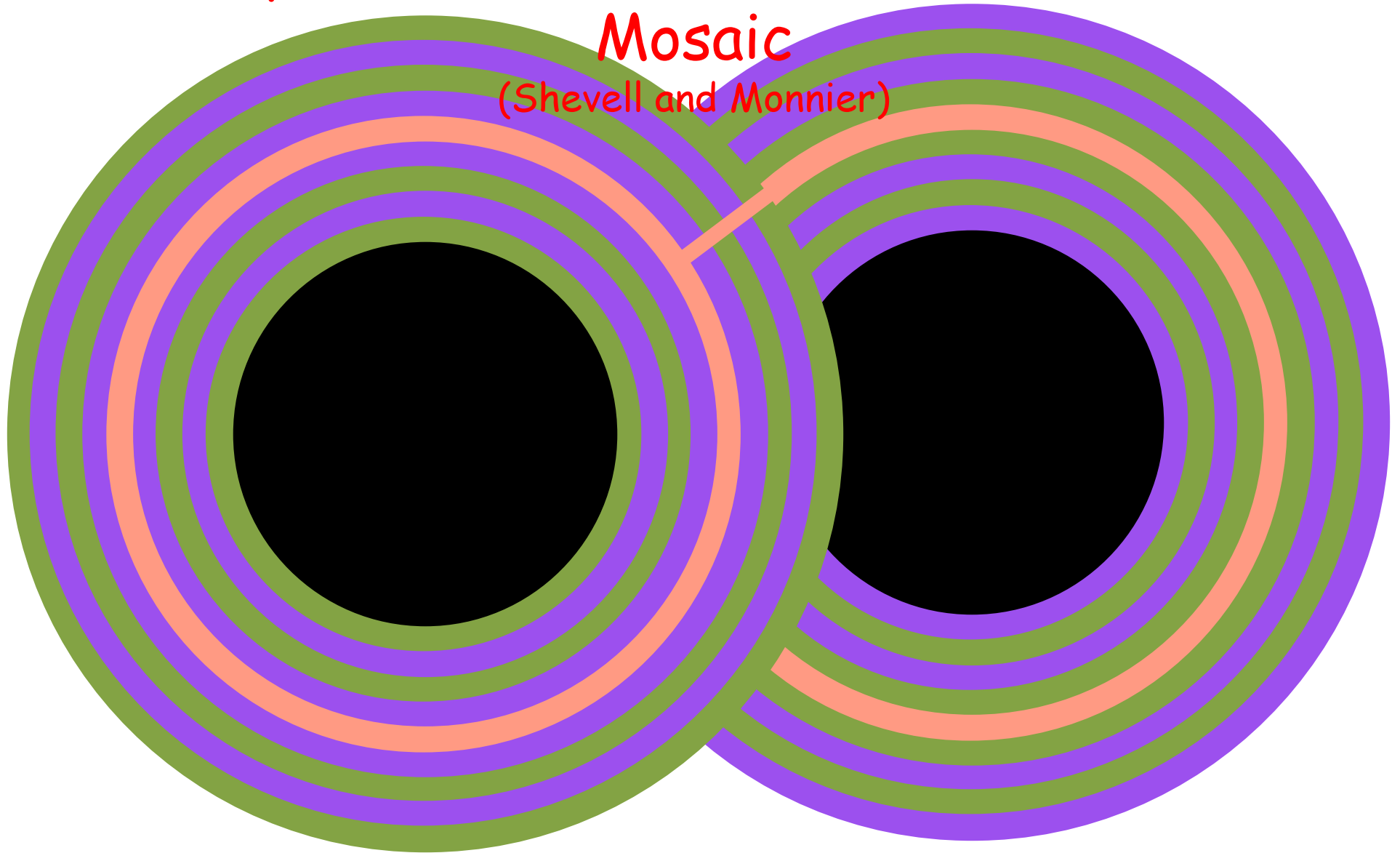

To
Understand
Appearance,
We Must
Understand
Image
Formation
And Spatial
Encoding

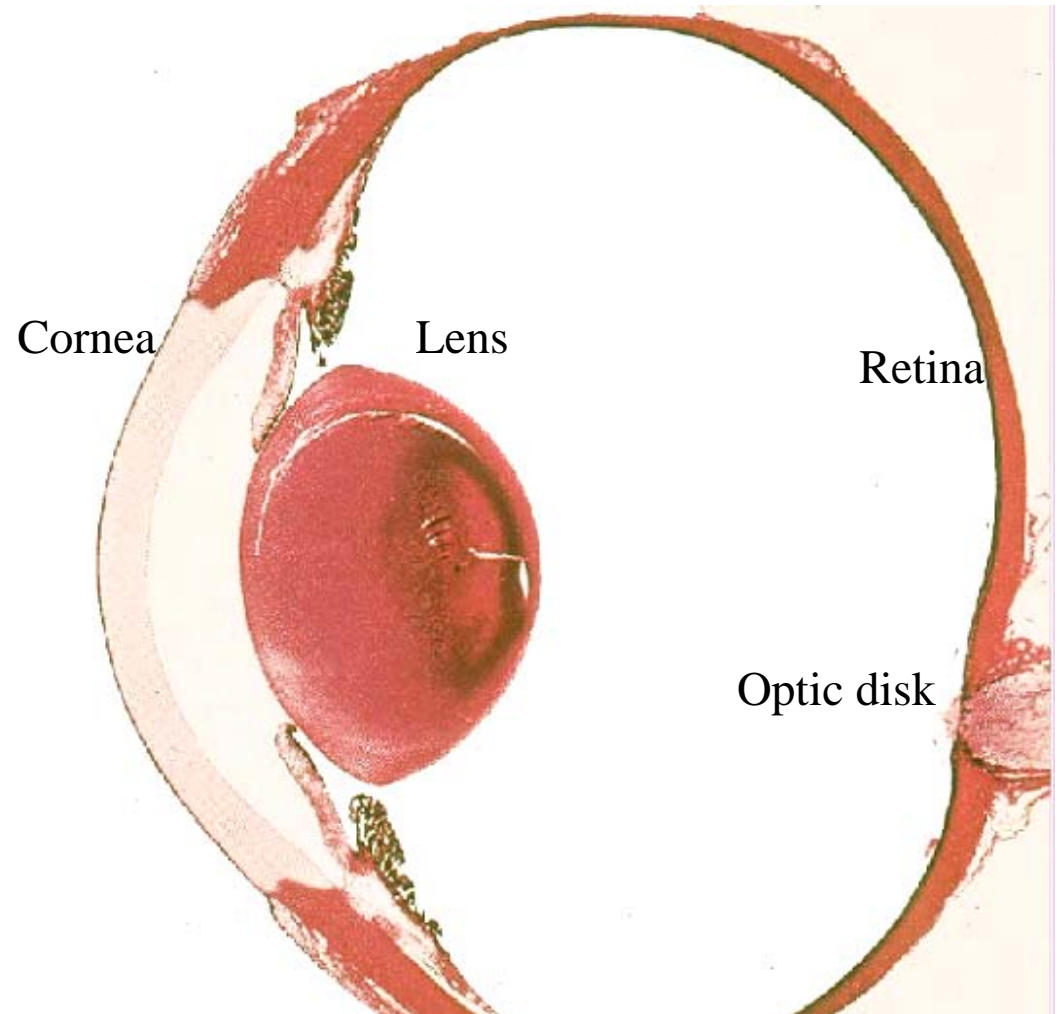

Chromatic Aberration Of The Human Image Formation Has A Large Effect on Color

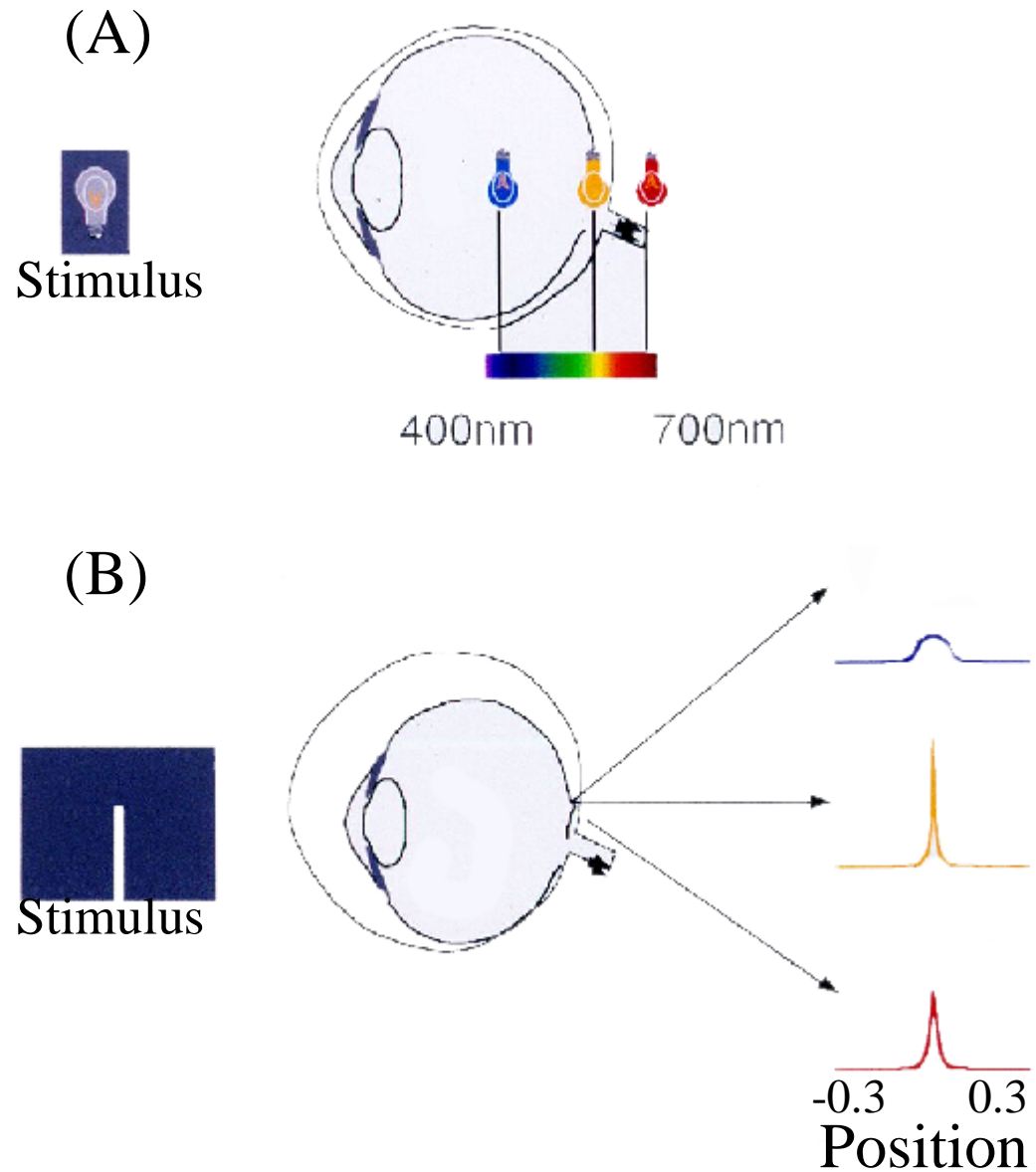

Chromatic Aberration Is Consistent Across Many Labs And Due To the Water In the Eye

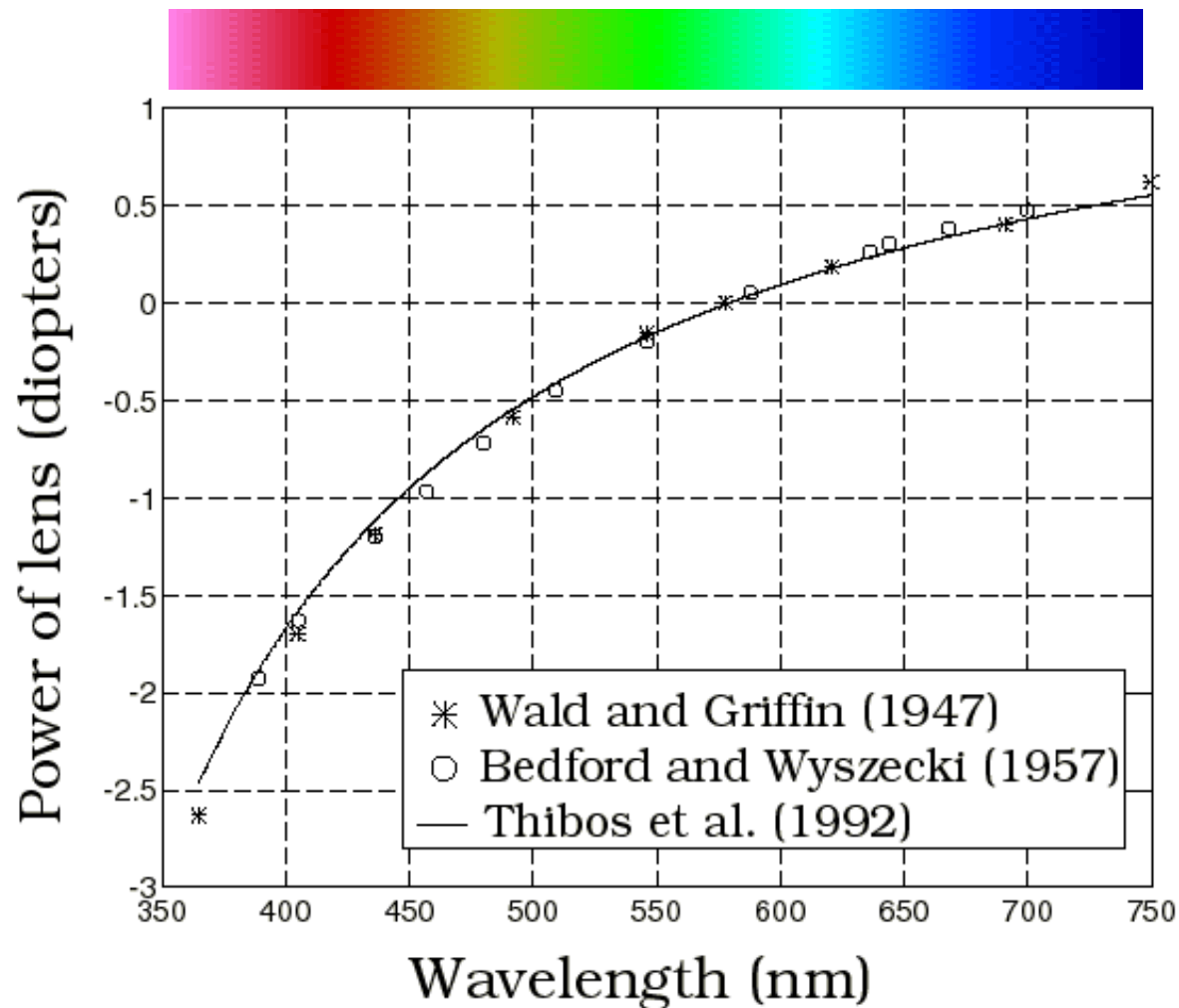

Chromatic Aberration Can Be Measured By Wavelength-Dependent Spread of The Linespread Function

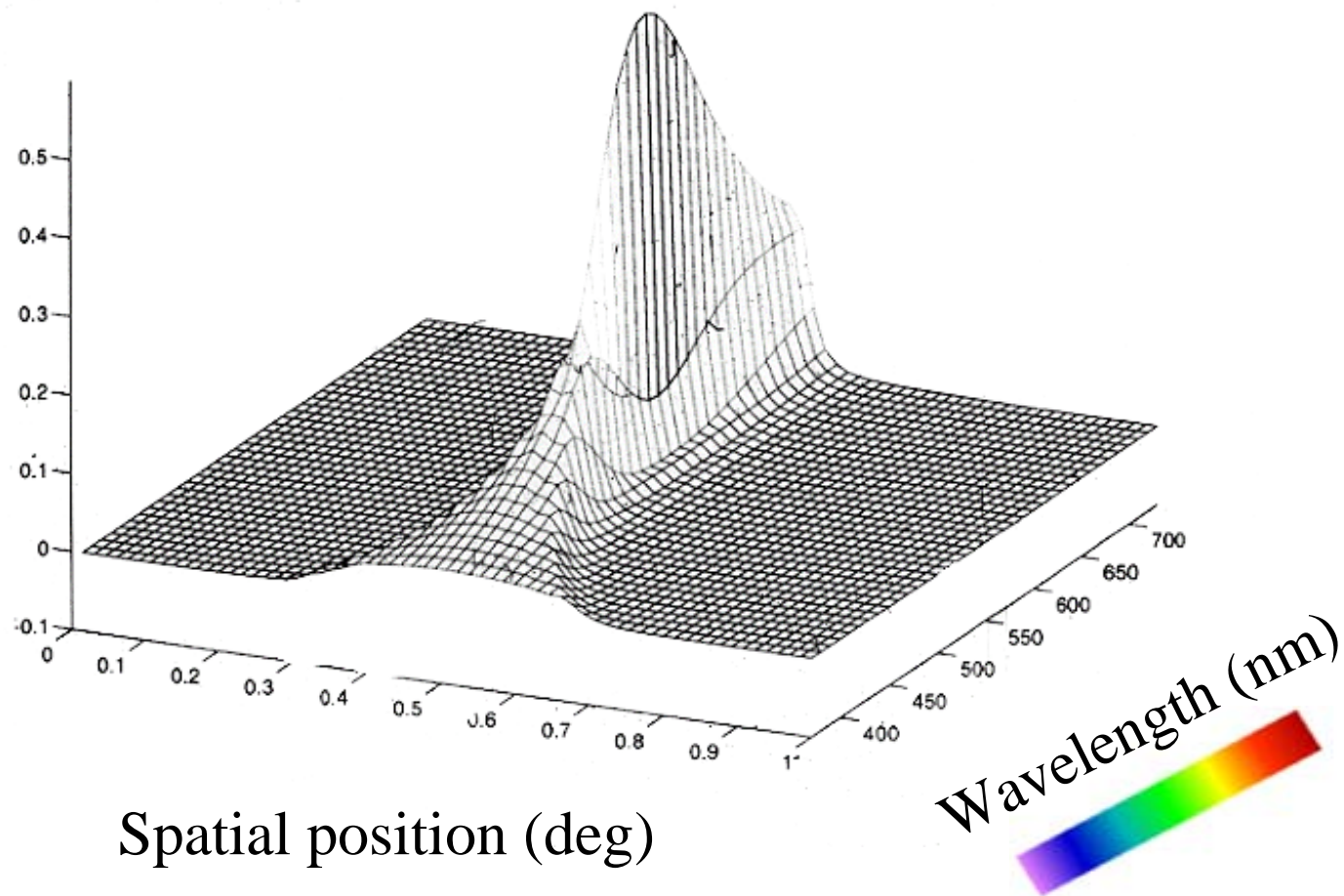

Chromatic Aberration Influences Appearance

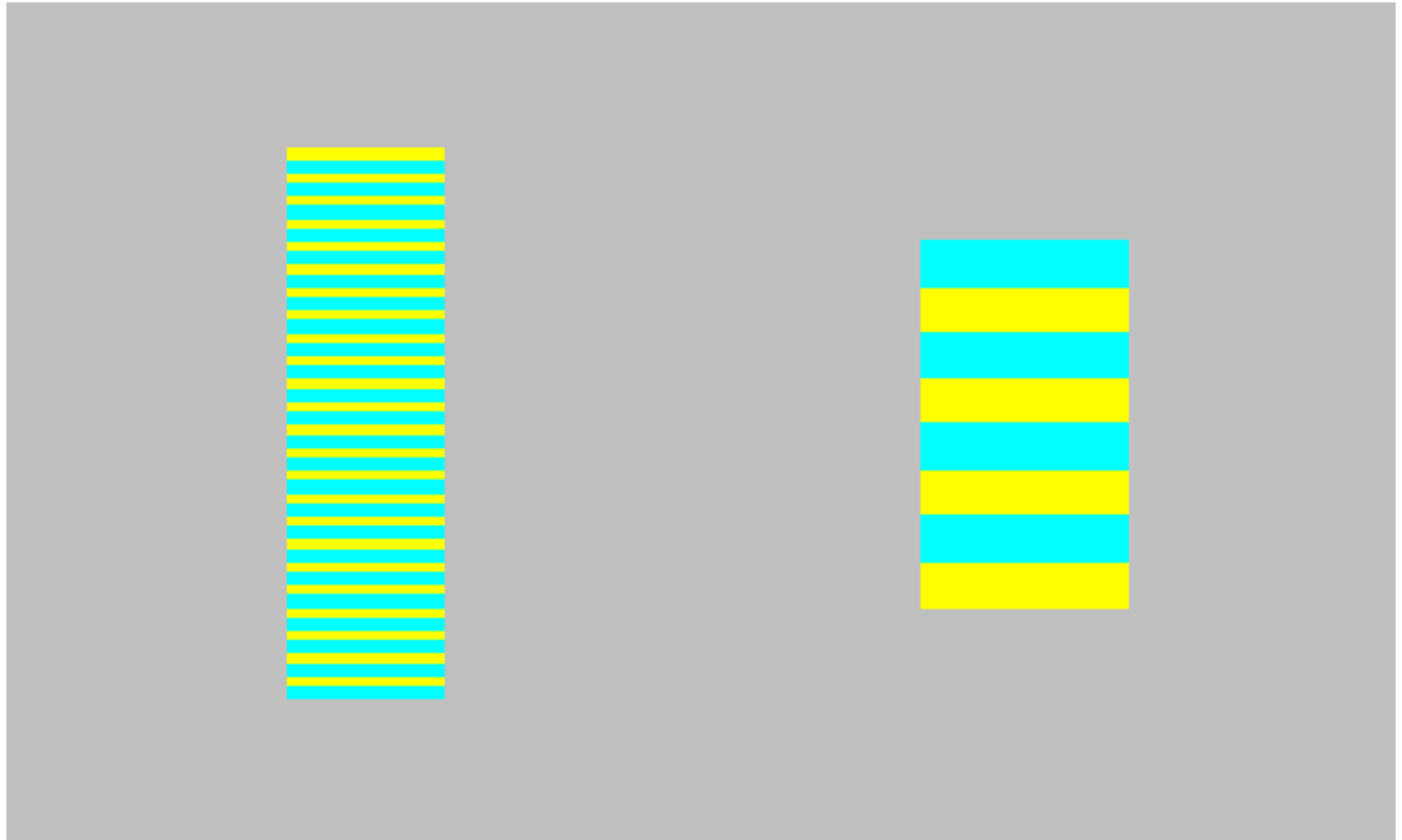

The Image Is
Encoded by
the Cones
And Then
Recoded for
Transmission
by the
Retinal
Pathways

Light enters



Ganglion On Off

**Bipolar
Horizontal
Amacrine**

Photoreceptors



50 microns

The Similarity Of Spectral Tuning Makes Cone Signals Correlated (Buchsbaum)

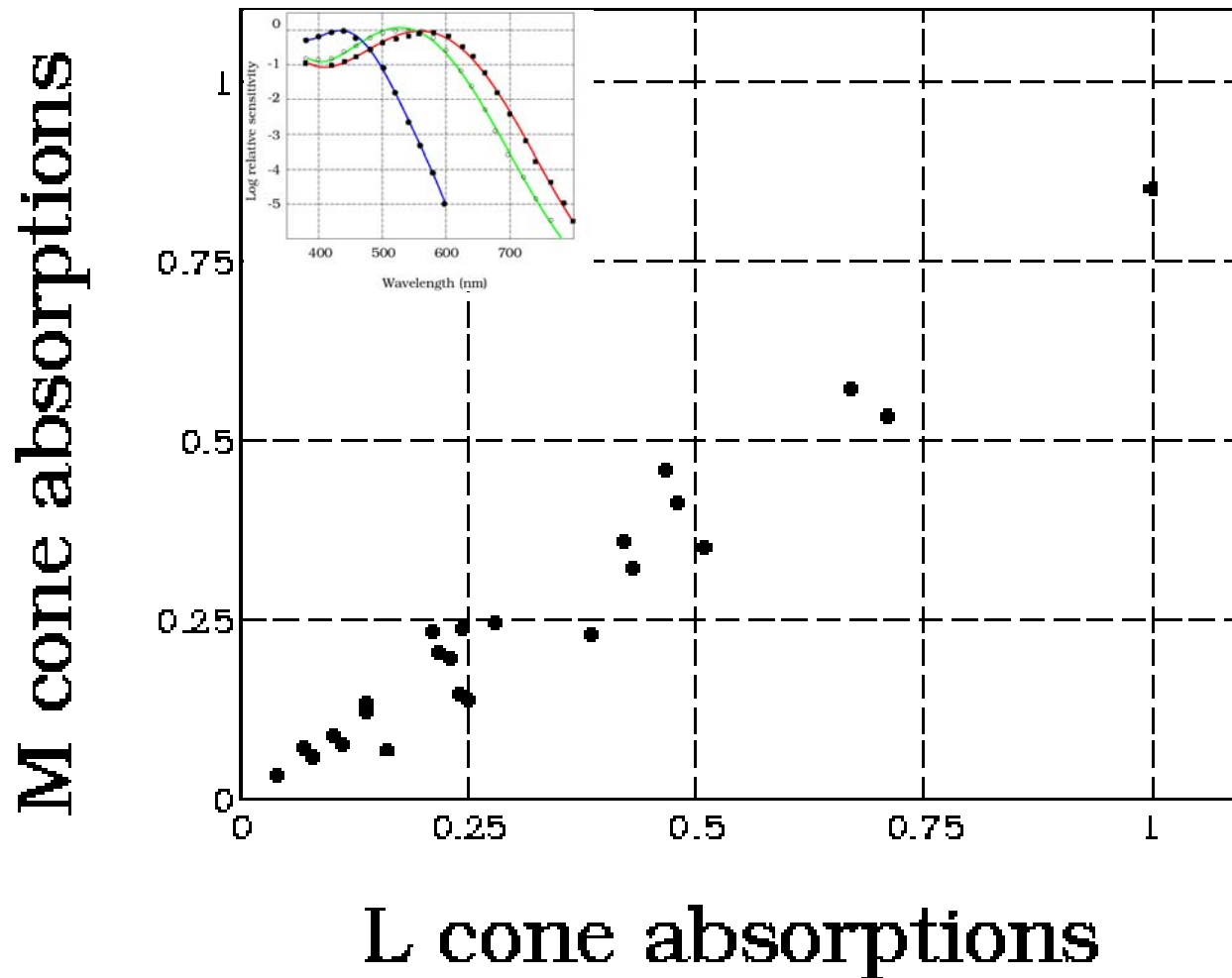

Appearance And
Sensitivity
Measurements
Show That Neural
Signals Reduce
the Correlation By
Carrying The
Difference
Between Cone
Signals

(Hering, Hurvich and
Jameson, Stiles, Boynton,
Stromeyer, Wandell)

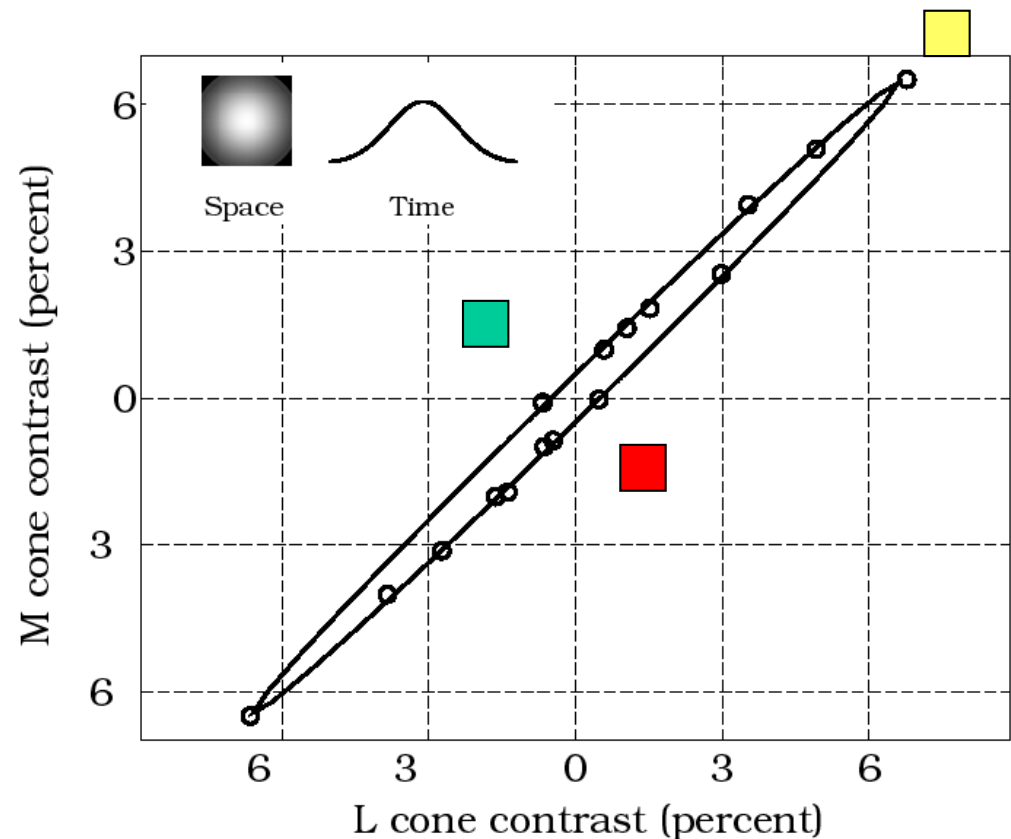

Colors Appear Red or Green, But
Not Red AND Green; Blue or
Yellow, But not Blue AND Yellow;
They Can Appear Red and Yellow

Hypothesis: This appearance regularity arises from retinal encoding



Hue Cancellation Experiment Measures Color Opponency Empirically

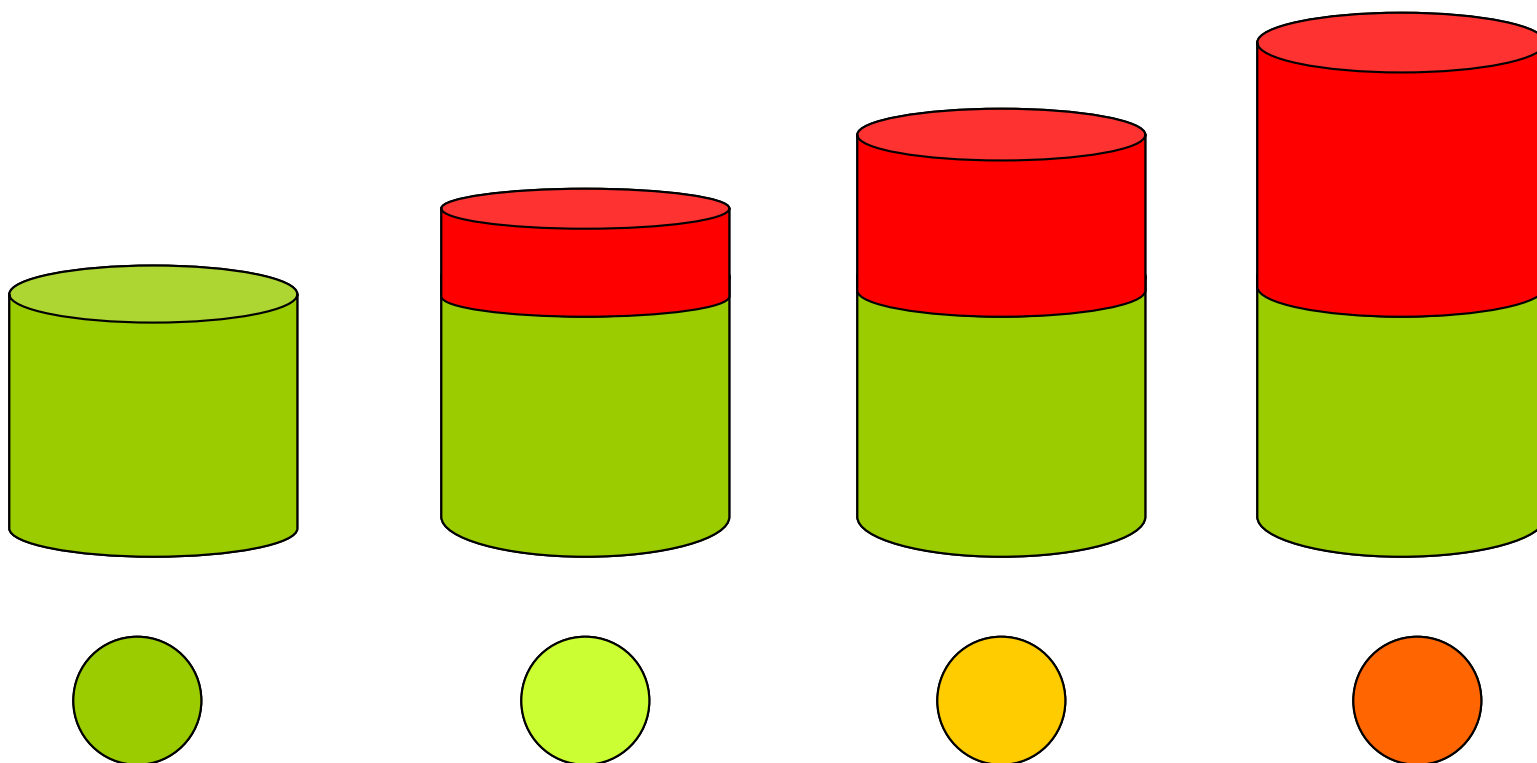

The Original Color Opponency Measurements Were Made by Hurvich and Jameson

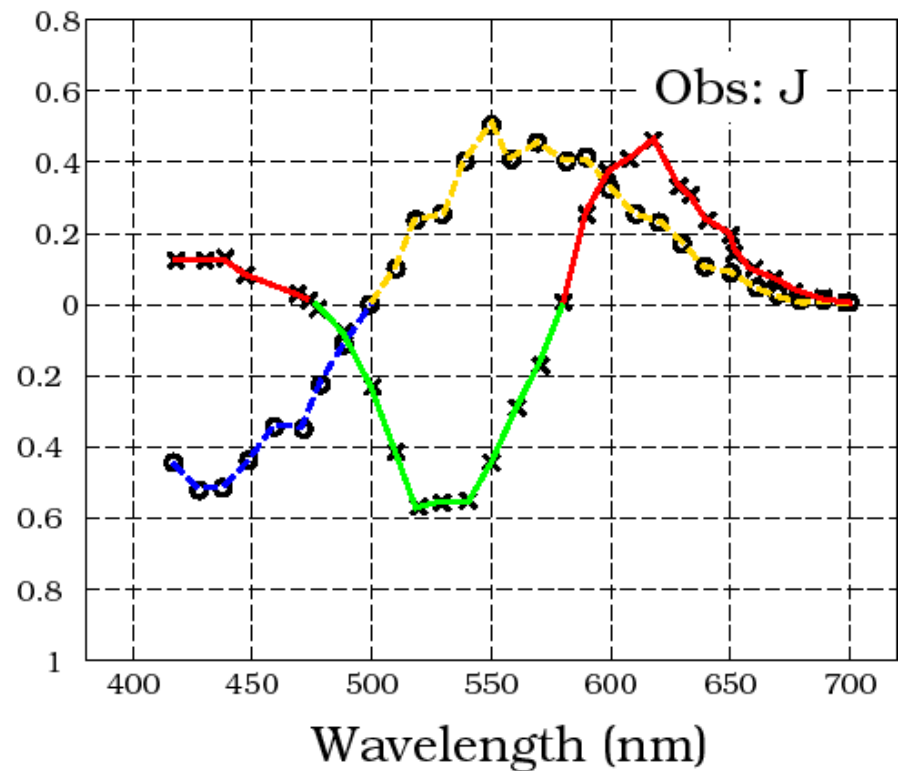
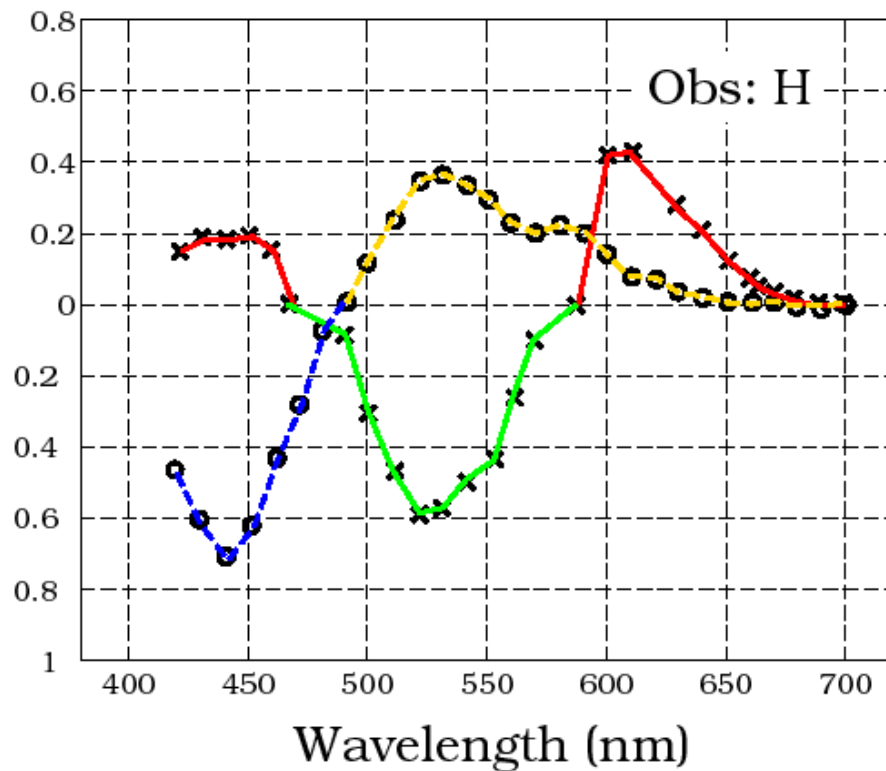

Human Retina By The Numbers

(Rodieck, 1998)

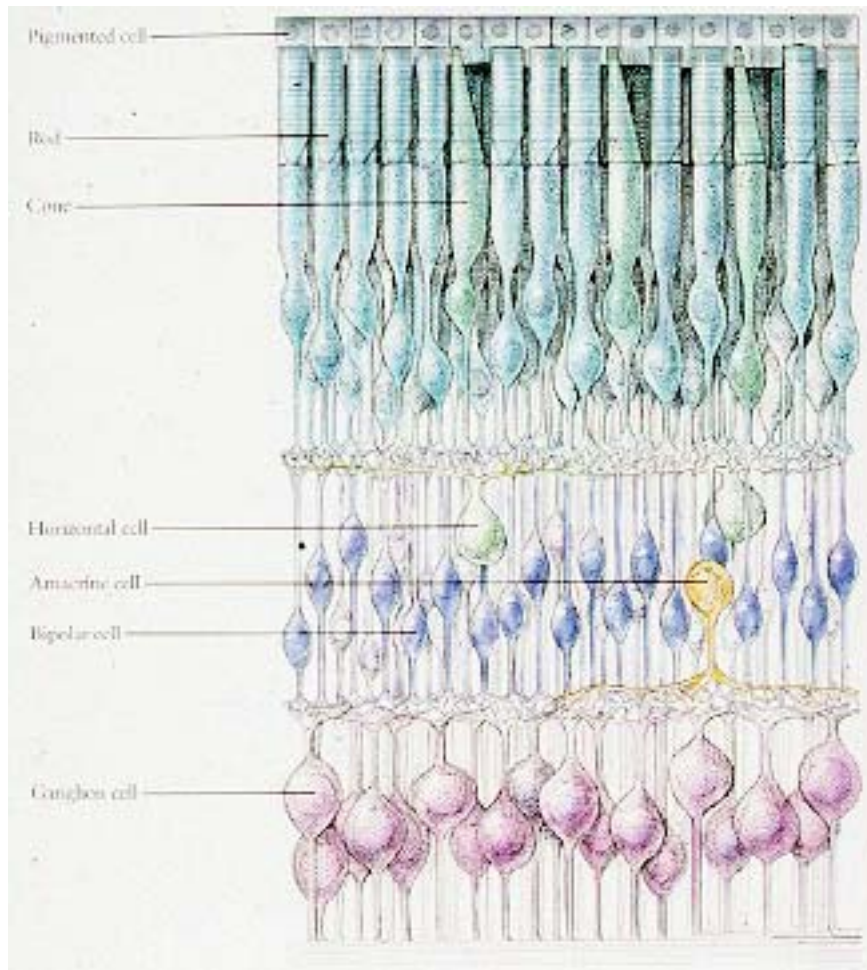

- 5 x 5 cm, 0.4 mm thick
- # cones: 5×10^6
- # rods: 10^8
- Cone width in fovea: 1 mu
- Contacts per cone: 250
- 10^6 optic nerve fibers

Spatial Distribution of Receptors Is Very Uneven Across The Retina

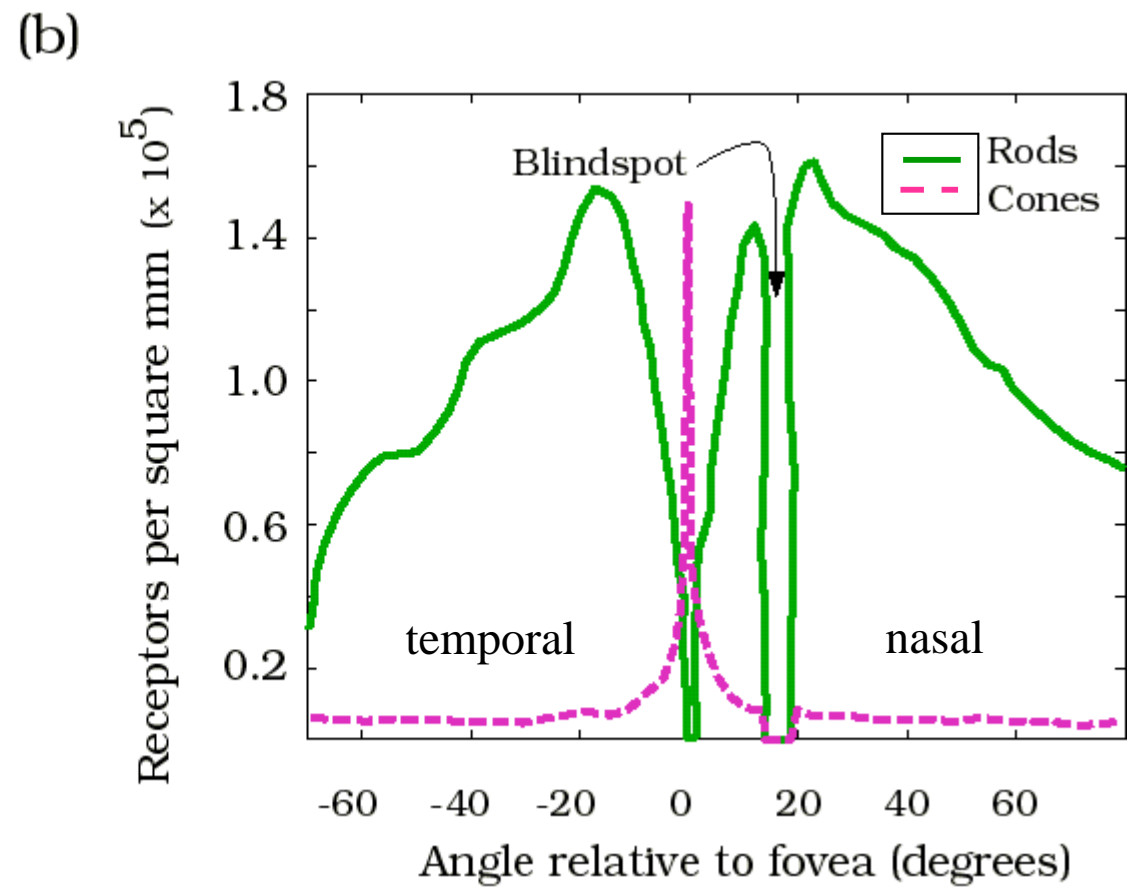
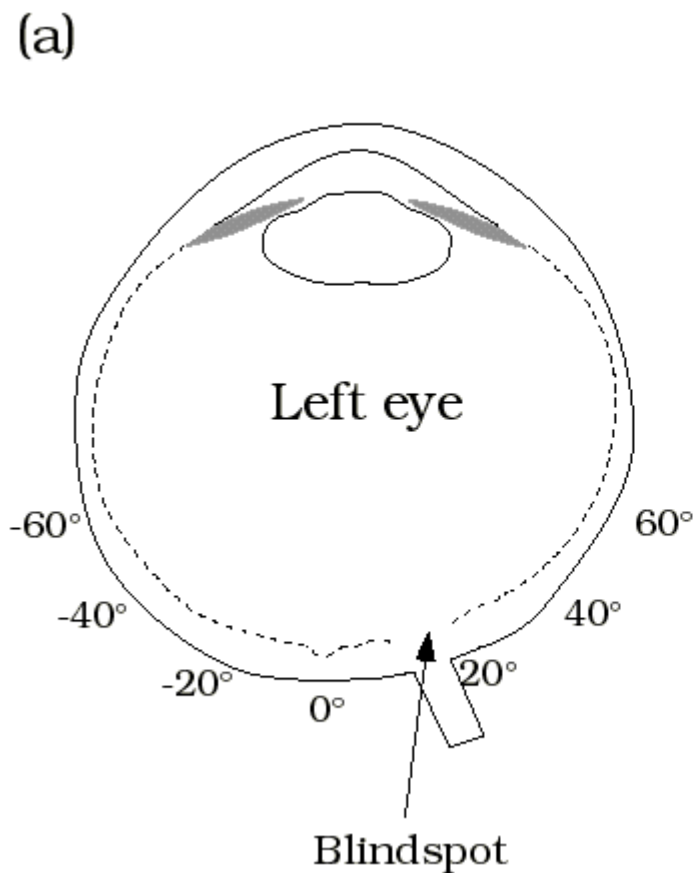

The Primate
Foveal Retina
Contains
Mainly Cones
And Is
Specialized
For High
Acuity and
Color

Light enters

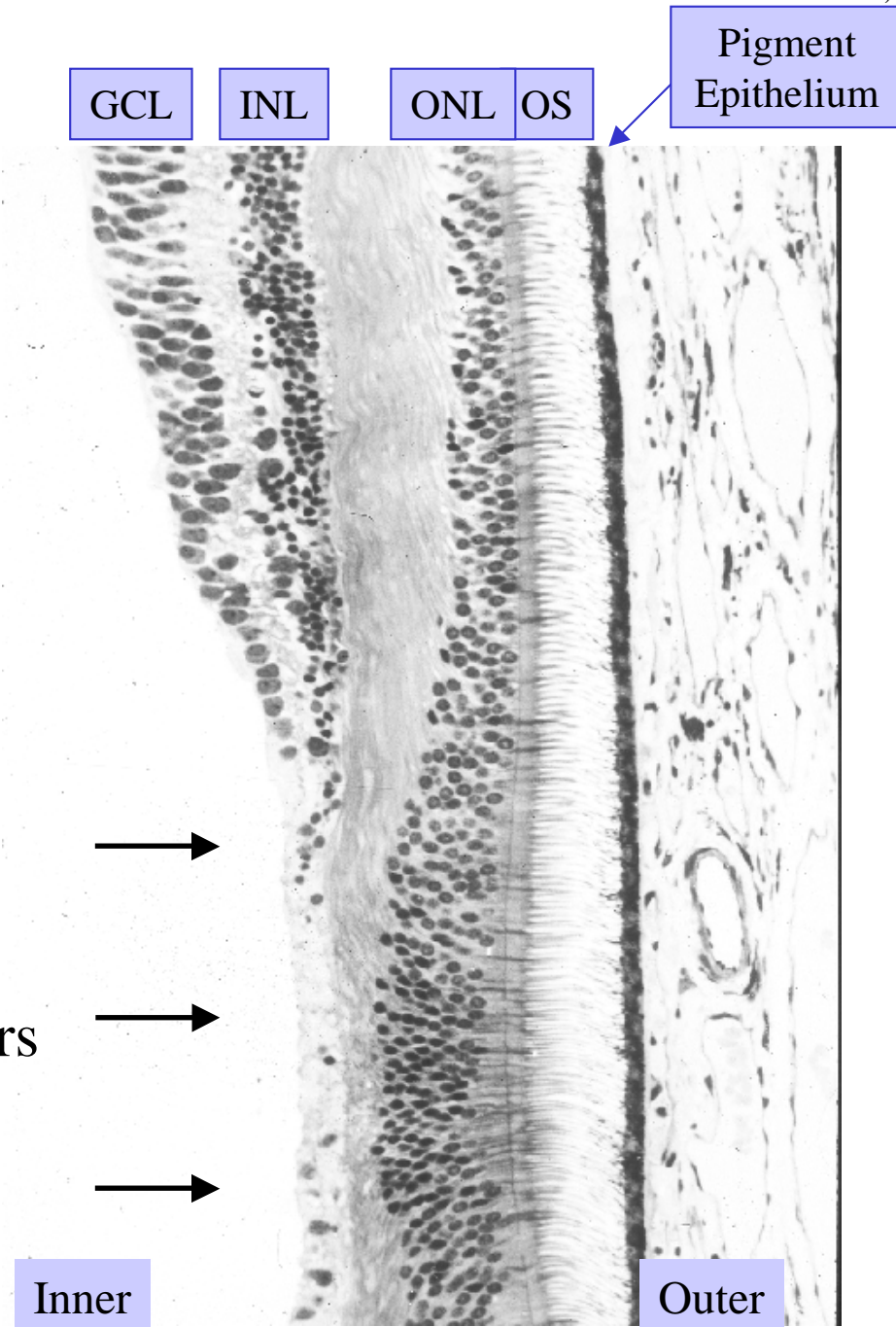

In The Fovea, The Cones Are Tightly Packed And Small; The Cones Are Larger and Interspersed With Rods in the Periphery
(Curcio et al., 1990)

Fovea

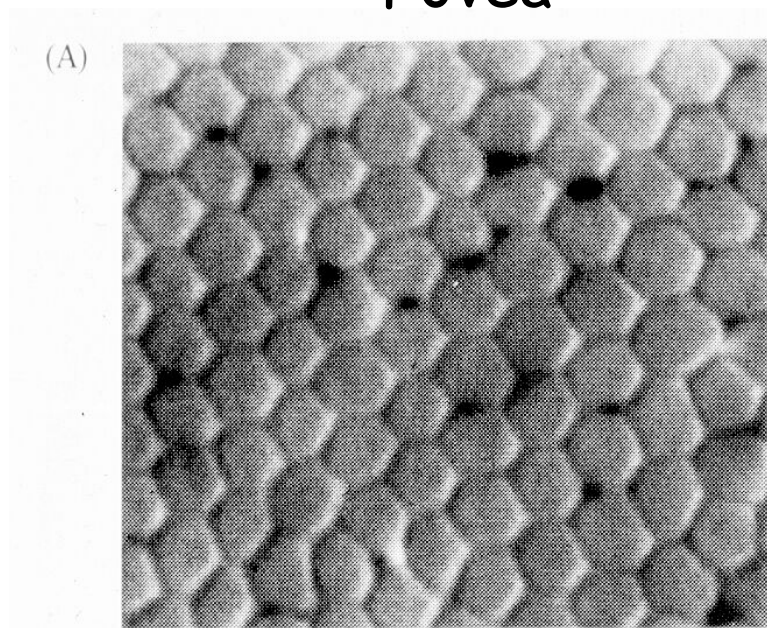

Periphery

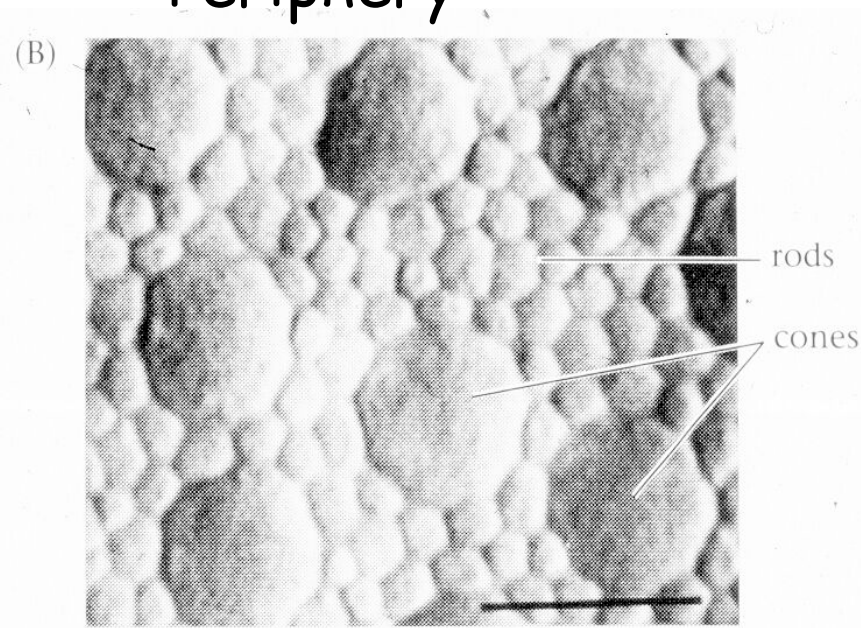

S-Cones Represent 7% (1/14) Of All Cones

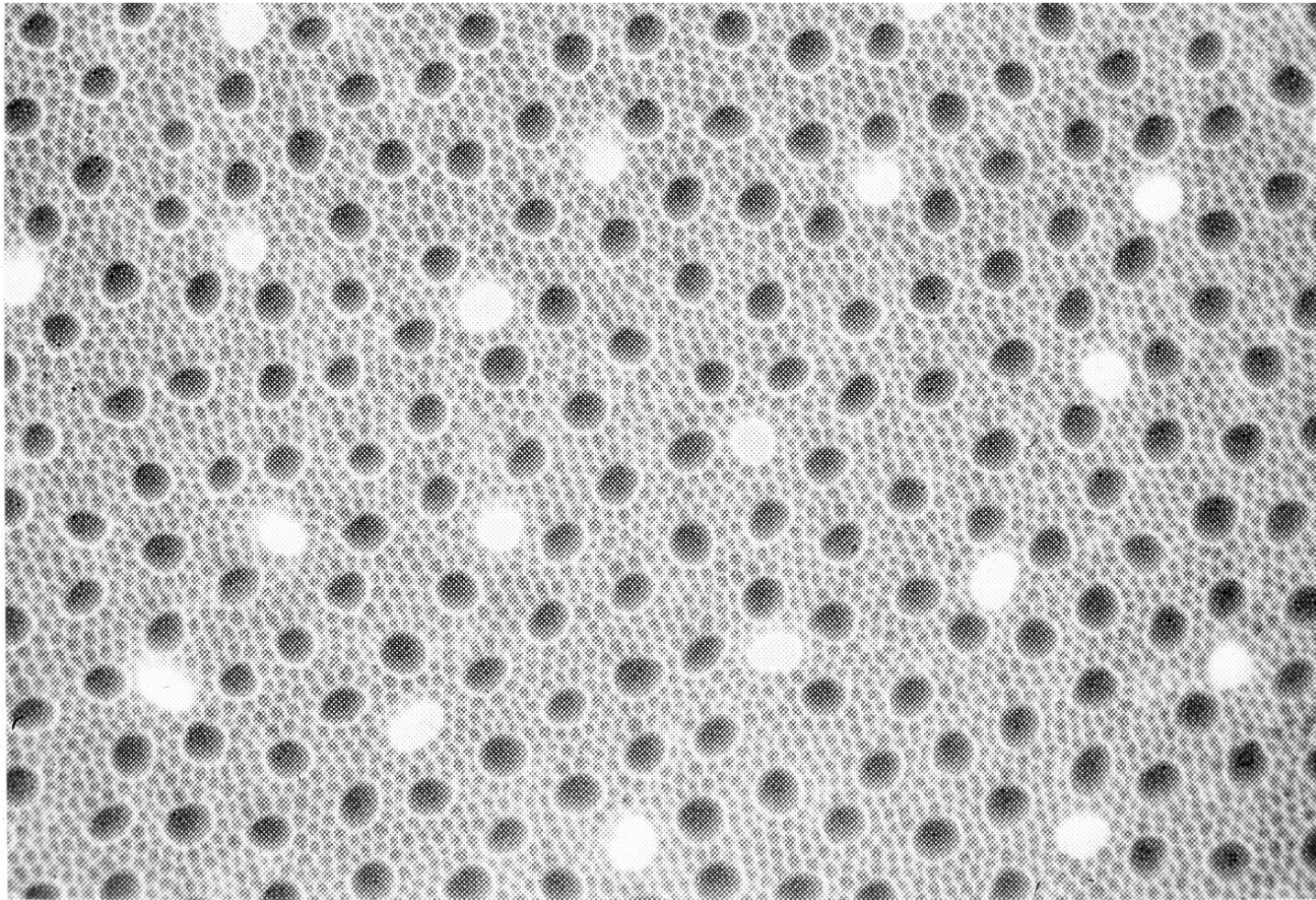

Retinal Cell Types Can Be Distinguished By Their Size And Branching Patterns (Dacey, 1993; Rodieck 1998)

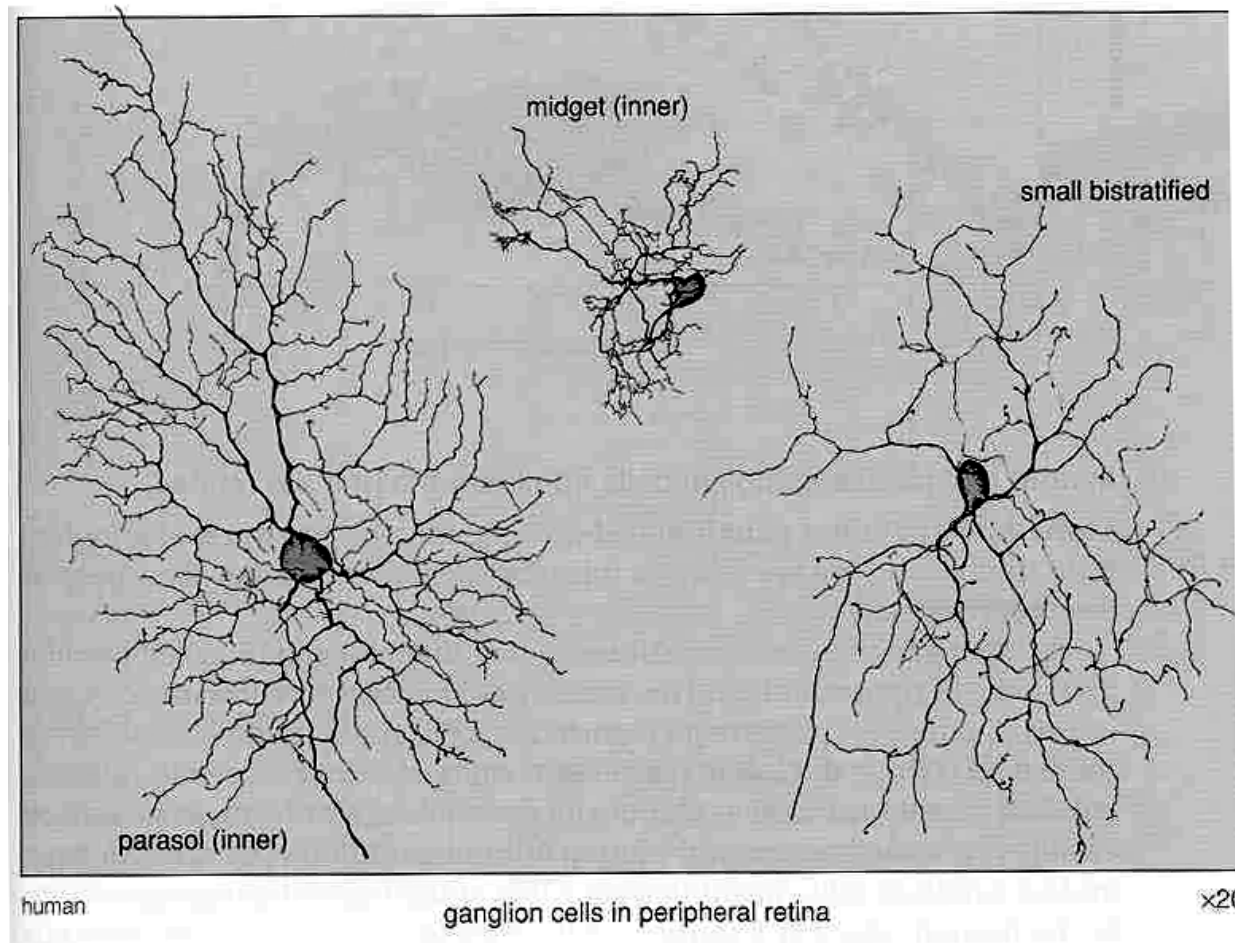

Cell Size Within A Class Usually Increases With Eccentricity

(Dacey, 1993; Rodieck, 1998)

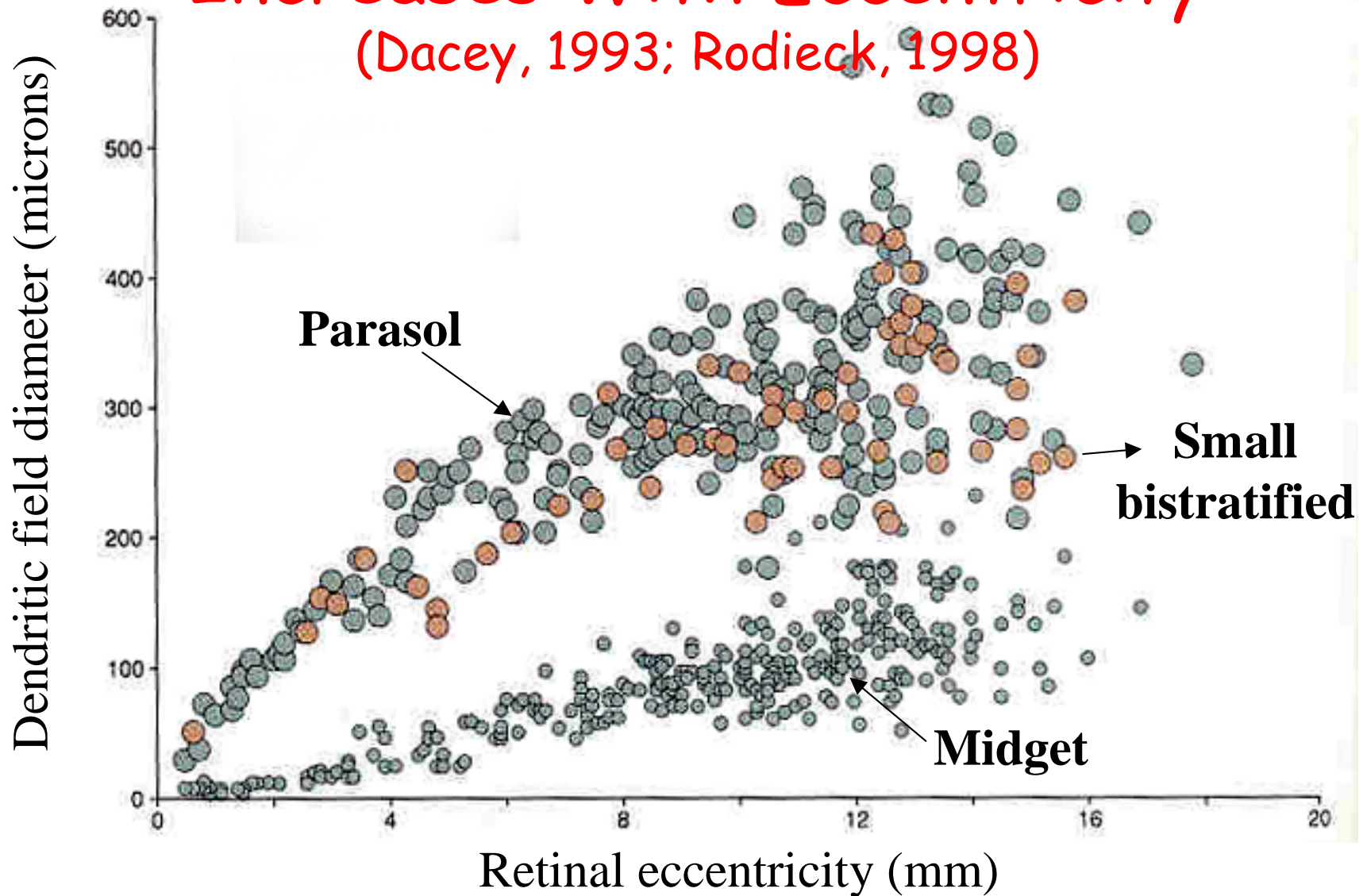

Multiple Retinal Pathways Exist, Having Very Specific Spatial Patterns of Cone Connections

(Rodieck, 1998)

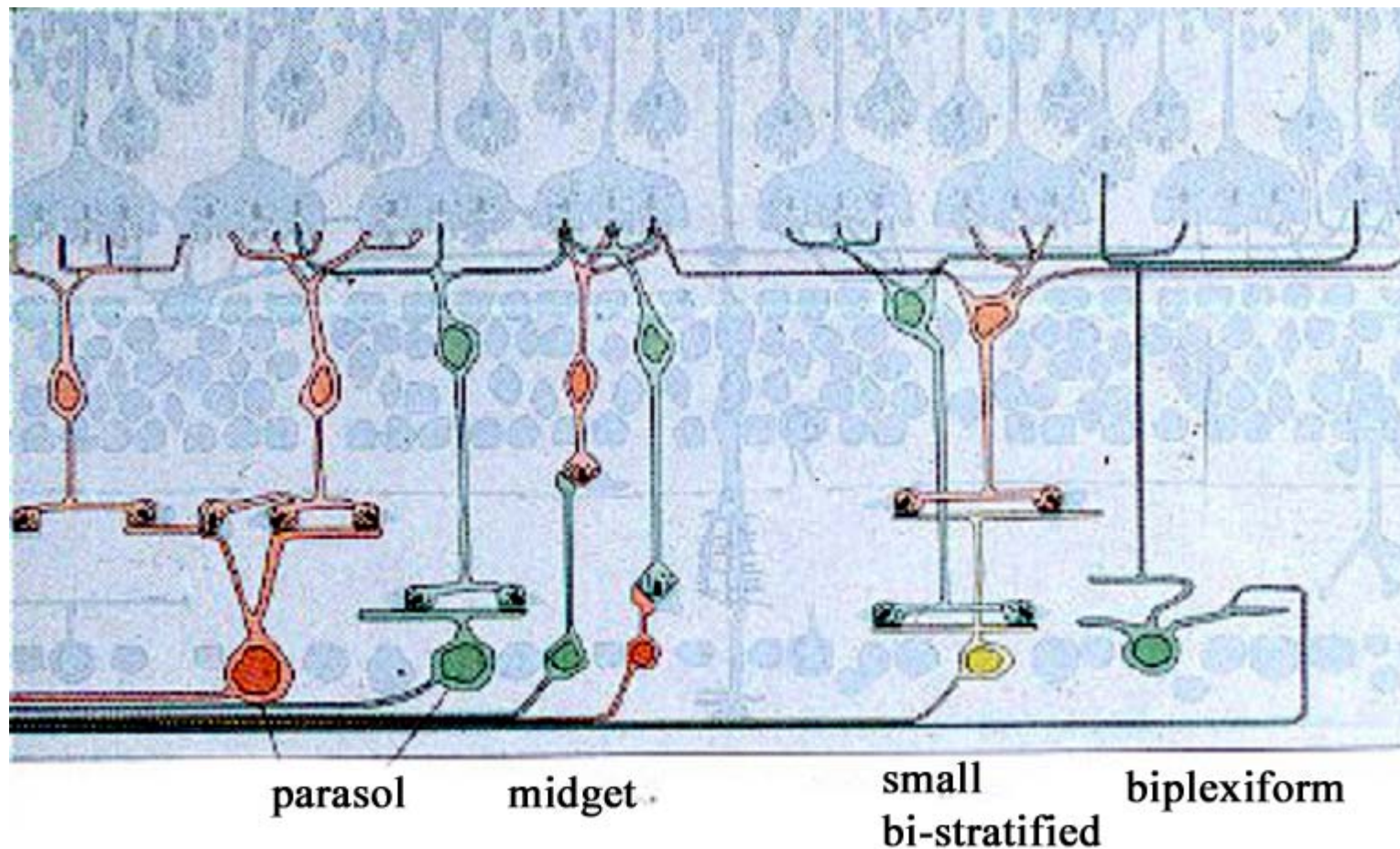

The Retina Contains A Specialized Rod Pathway

(Macaque rod pathway: Massey in Rodieck Book)

Rod bipolar

AII amacrines

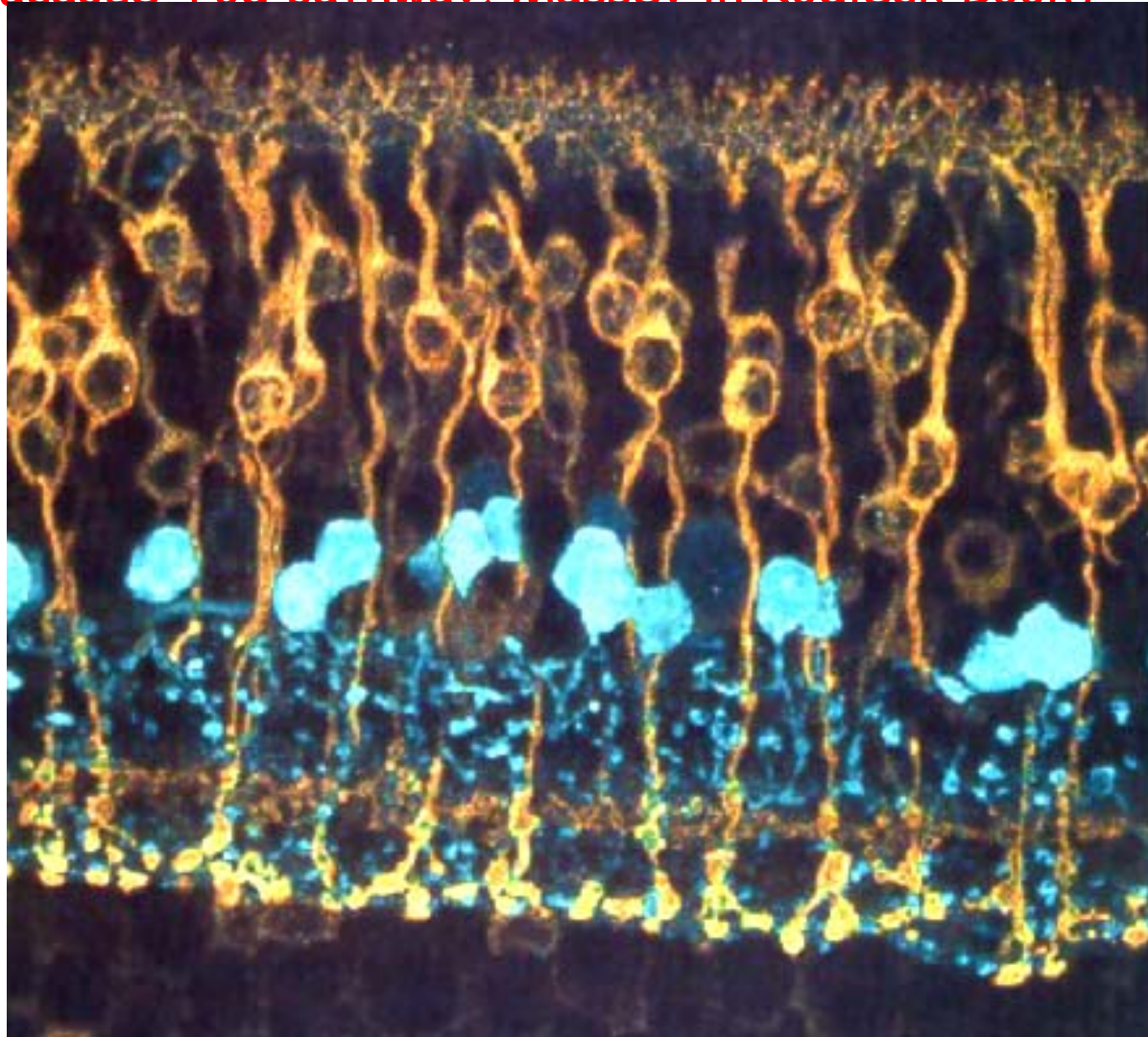

There Is Highly Specialized S-Cone Circuitry

(Calkins, J. Del Valle, Kouyama and Marshak, 1992)

S-cone bipolars receive exclusively from S-cones and are pre-synaptic to the small bi-stratified retinal ganglion cells

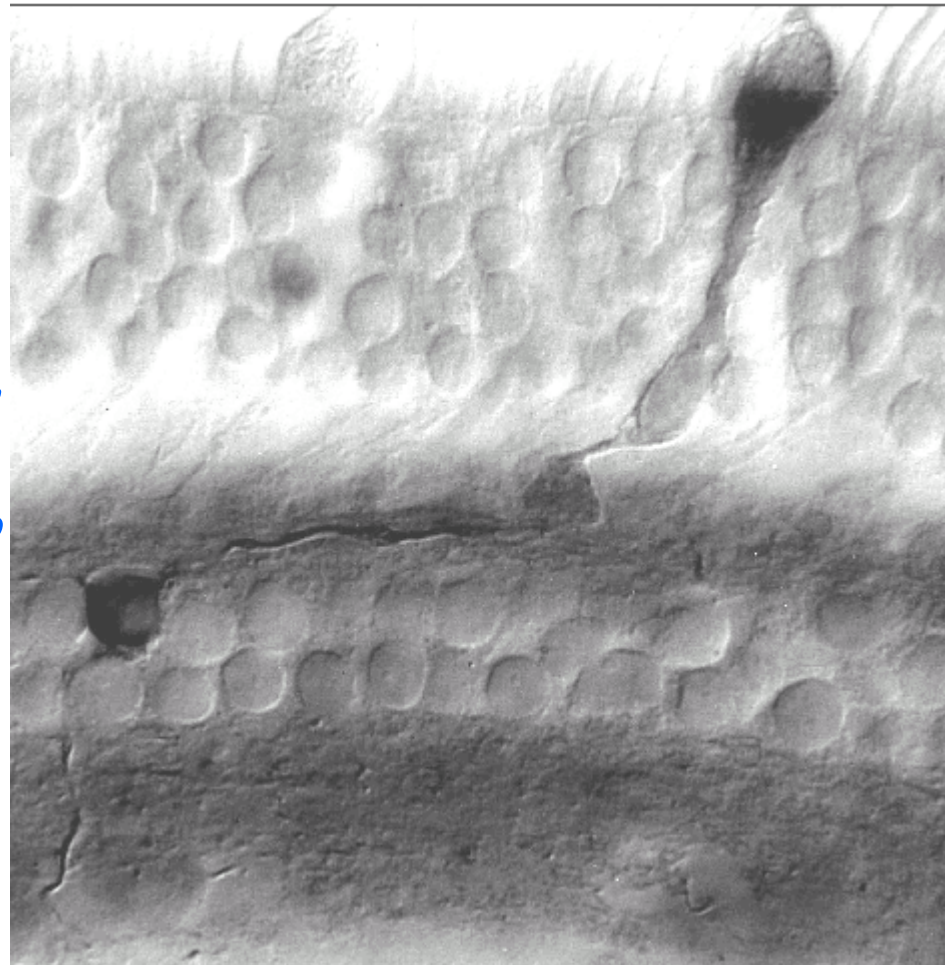

S-cone

Identified using an antibody for the neuropeptide cholecystokinin (CCK)

A Major Retinal
Output For S-
cone Signals Is
the Mosaic of
Small Bi-
stratified
Ganglion Cells

(Calkins)
(Calkins and Sterling)

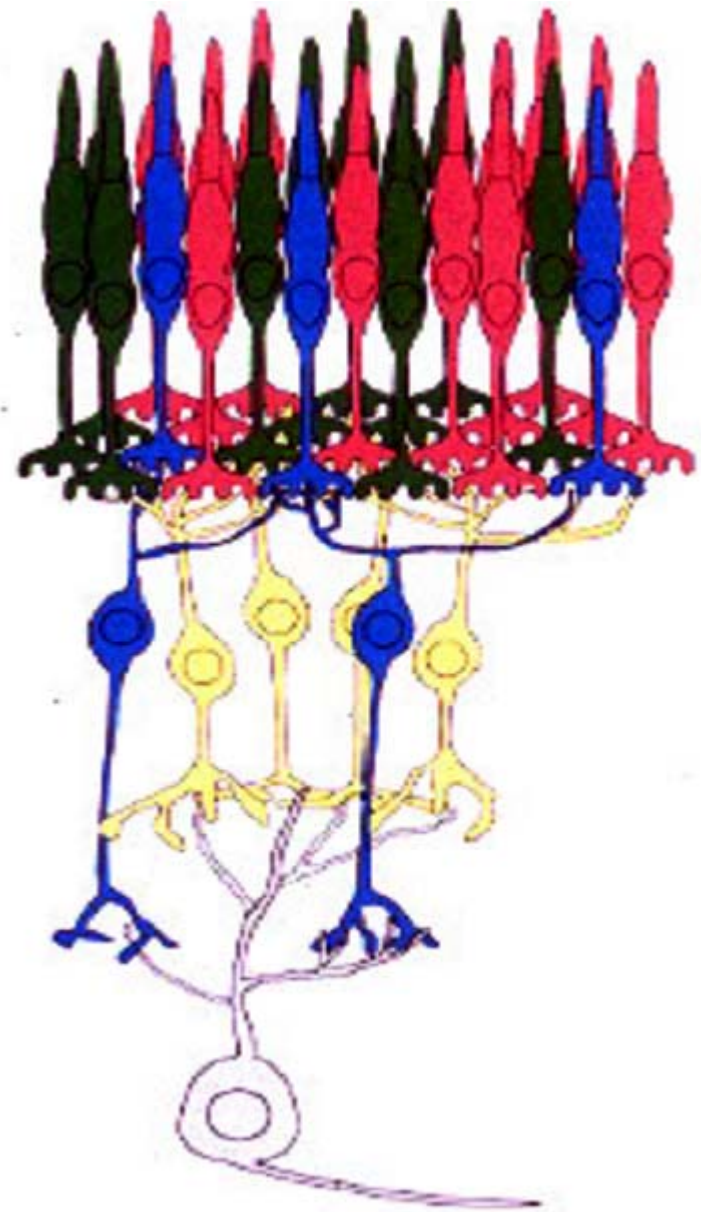

Hypothesis:
The Spatial
Organization of
the Cone Inputs
To The Retinal
Pathways Are The
Origin of
Perceptual Color
Opponency

(DeValois, 1959, 1964
Hubel and Wiesel, 1966;
Calkins and Sterling, 2001)

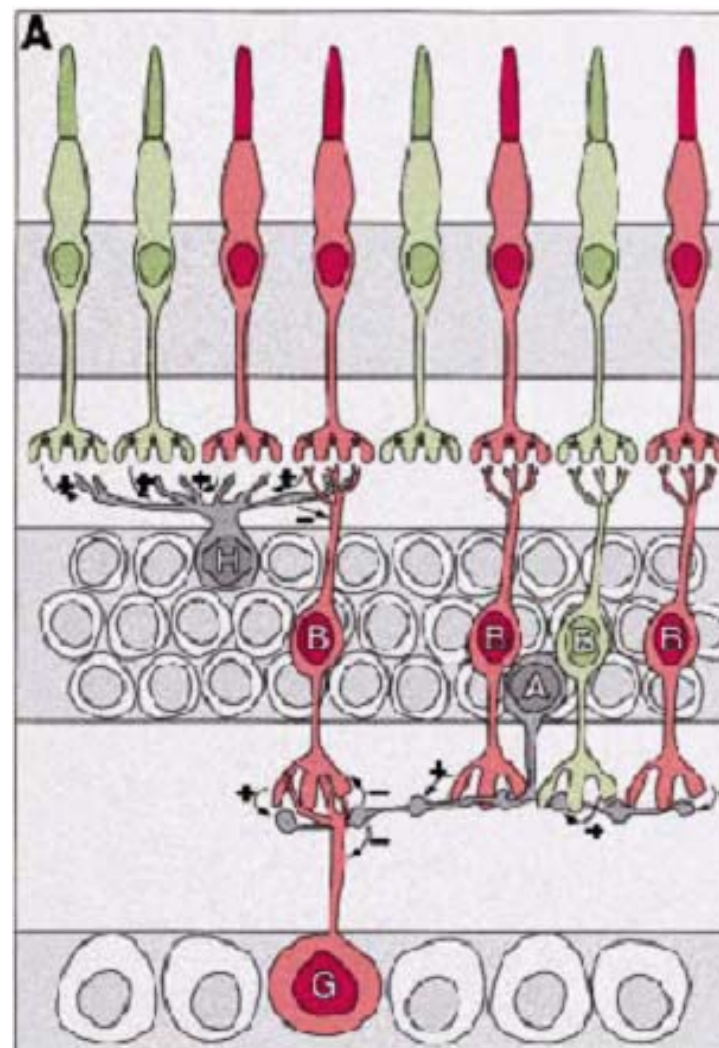

A Sweep Frequency Conveniently Illustrates The Measurement of Spatial Contrast Sensitivity

Wandell, CIC 2002

Increasing contrast

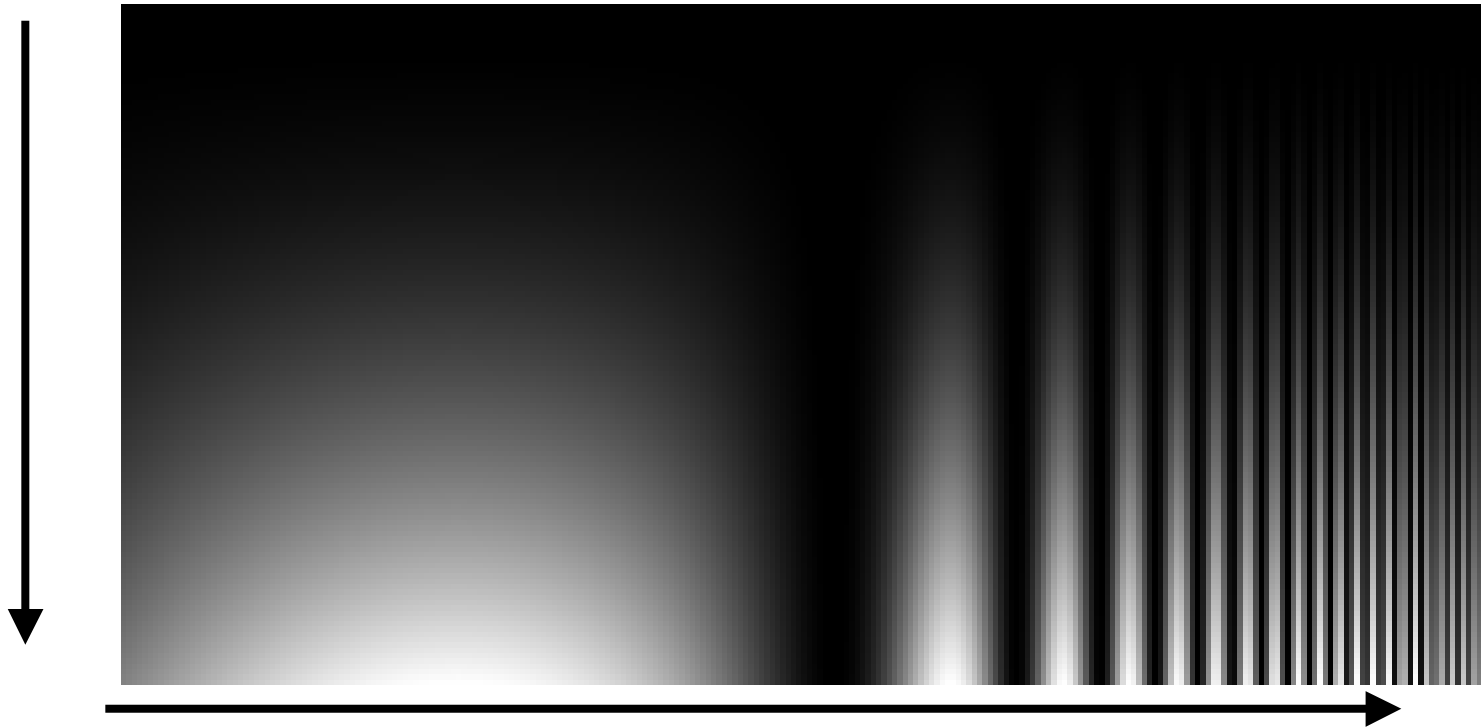

Increasing spatial frequency

The Ability To See Color Varies With The Stimulus S-T (D. H. Kelly, 1979)

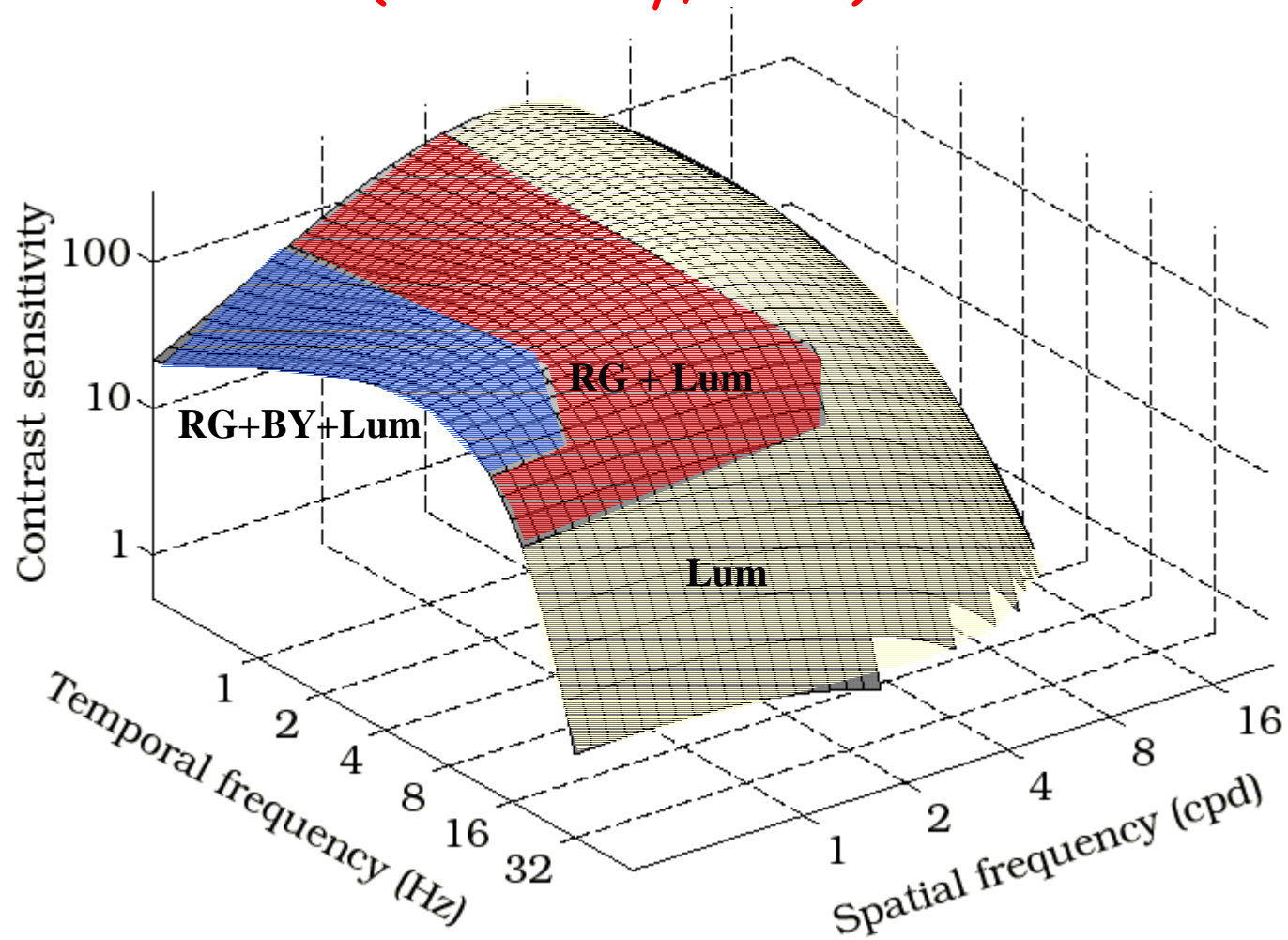

Trichromacy is Restricted To A Subset of the Visible Spatial Temporal Regime

Limiting factors:

Chromatic aberration

Retinal encoding

Other factors?

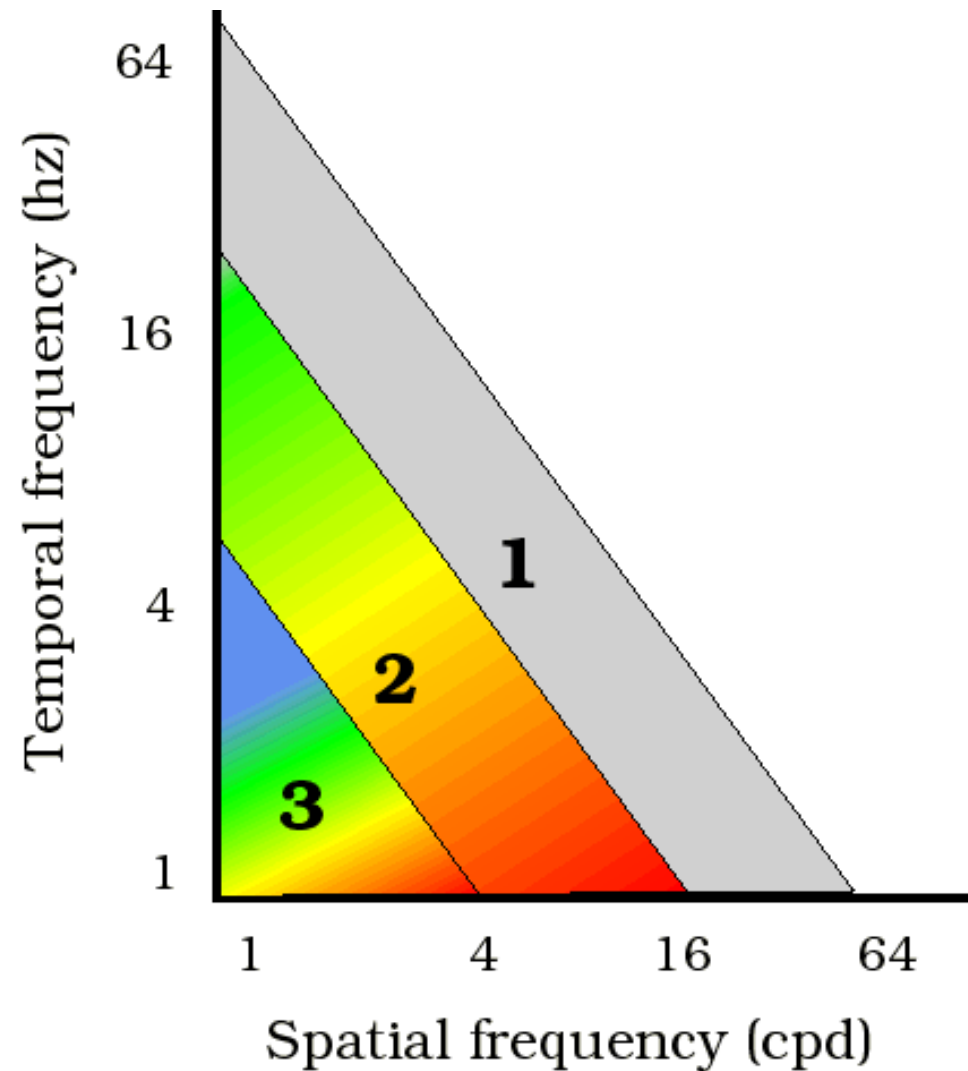

Poor Spatial
Resolution For
Color Is the
Basis for
Compression
in NTSC and
JPEG



Y

I

Q

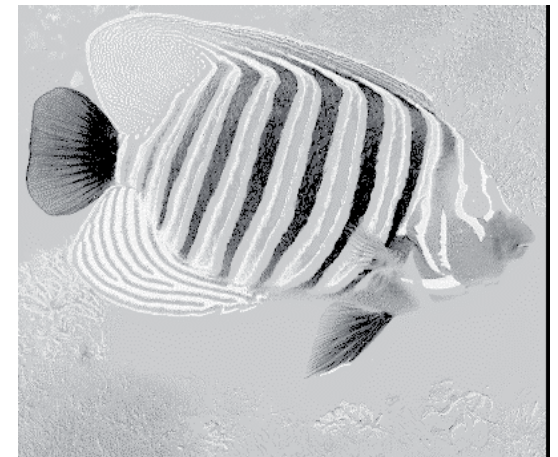
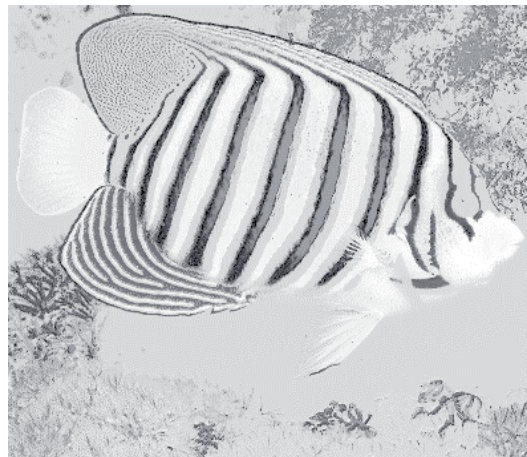

Blurred Y

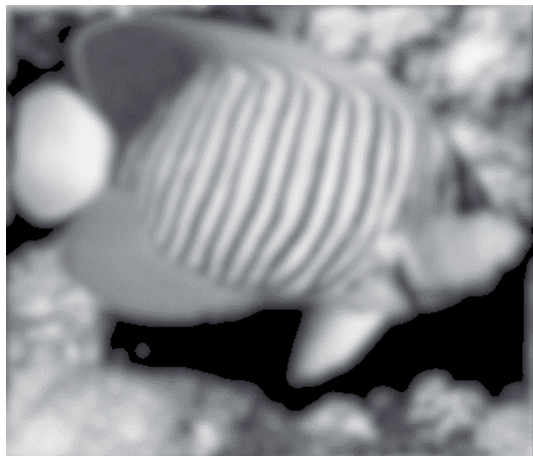

Blurred I



Blurred Q



**Blurred Y
I,Q**

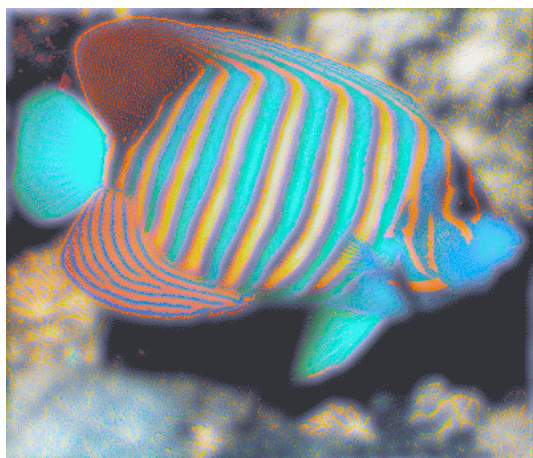

**Blurred I
Y,Q**

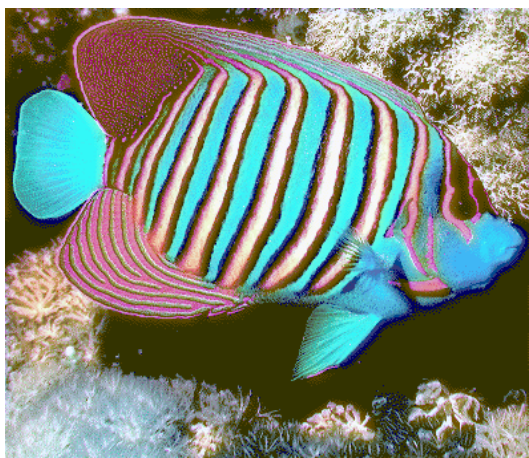

**Blurred Q
Y,I**



Color Opponency Is Implicit In Color Metric Standards



Spatial and Temporal Variations In Color Sensitivity Are Significant

*Reduced
luminance
contrast*

Original

*Reduced
blue-yellow
contrast*

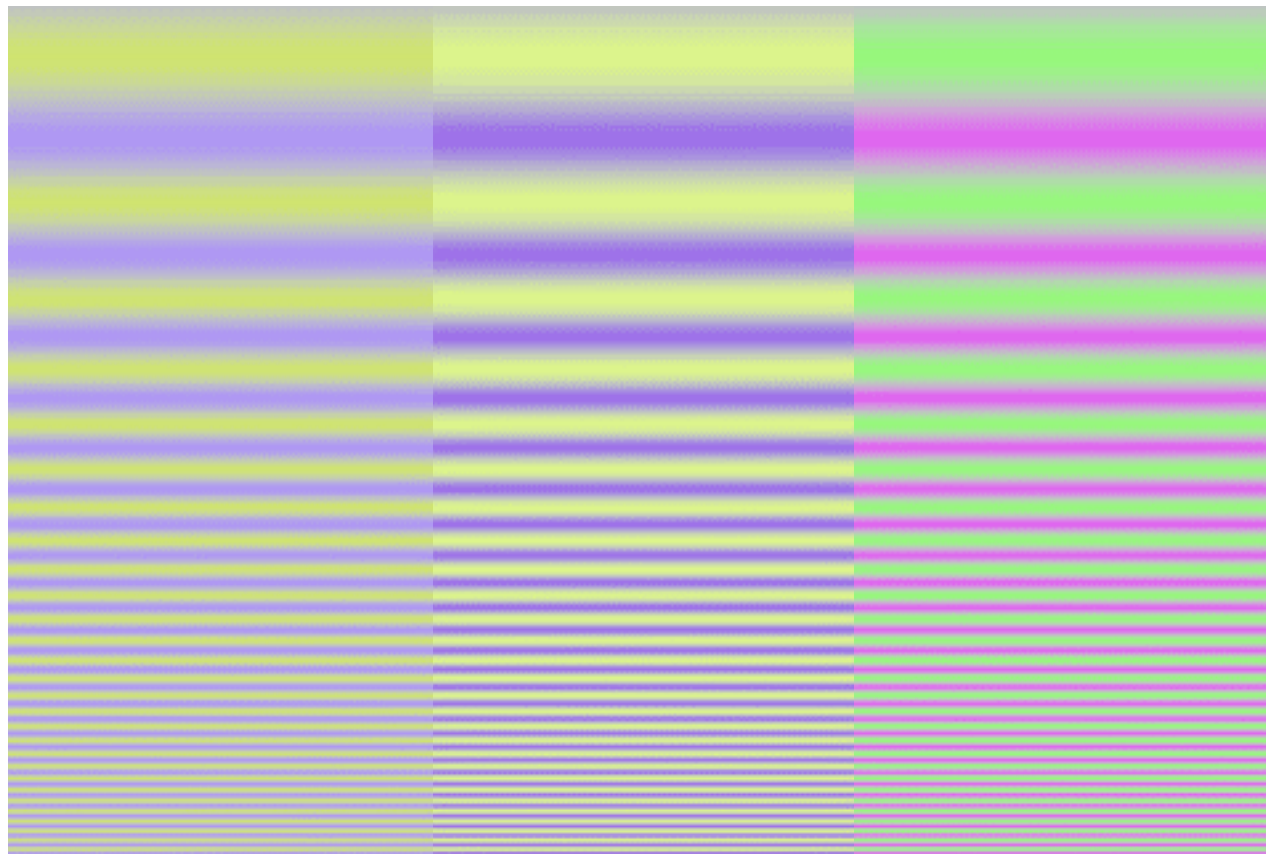

Color Appearance Degradation Can Be Measured Using Asymmetric Color Matching

(Poirson and Wandell, 1993)

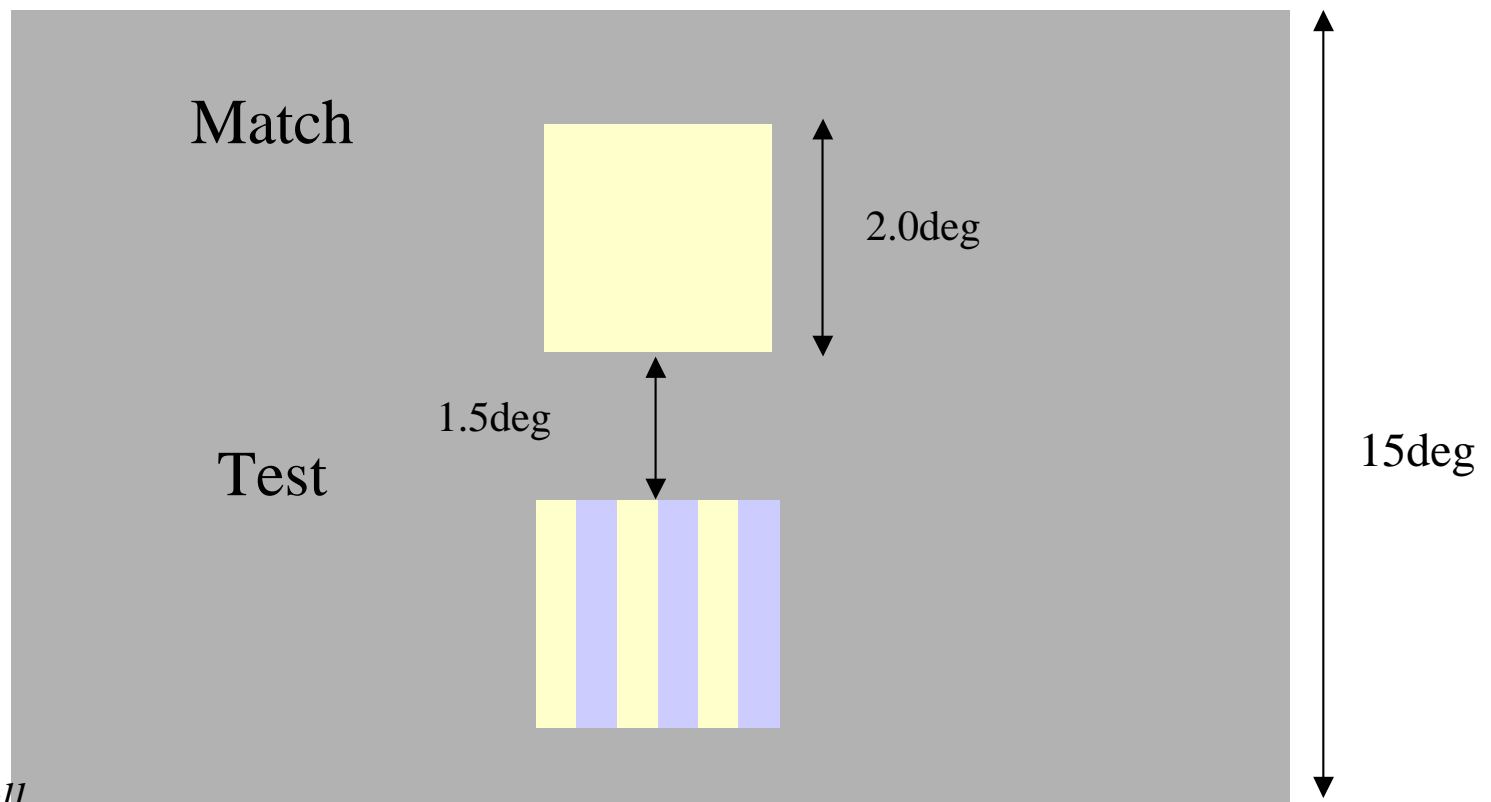

*Poirson and Wandell,
J. Opt. Soc. Am A, 1993,
10, no. 12, pp. 2458-2470*

Spatial CIELAB Is A First Attempt To Extend Color Metrics (Zhang and Wandell)

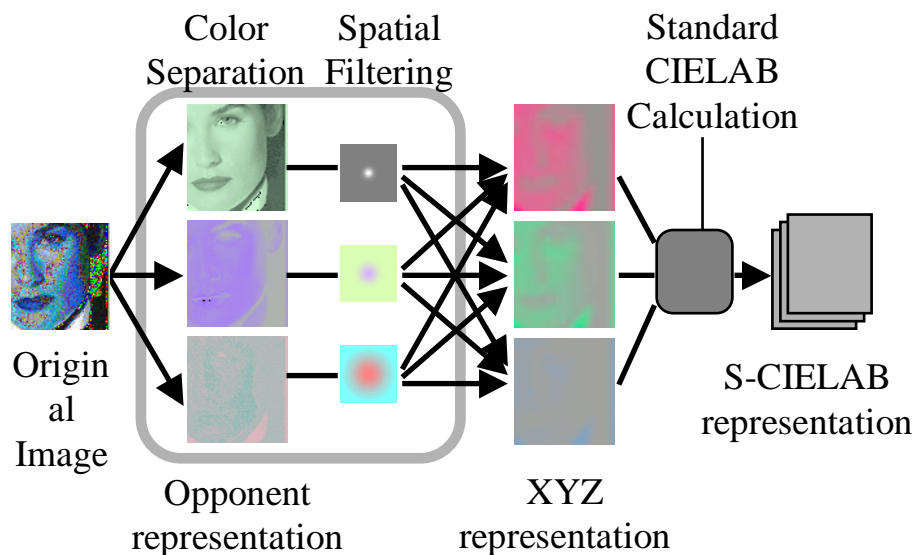

- Backward compatibility
 - Gives identical result as standard CIELAB when input is uniform area.
- Modular design
 - Easy to upgrade to newer CIELAB standard such as CIE94.
- Spatial filtering on linear opponent representations
 - Filtering occurs before CIELAB calculations, because linear filtering should be performed on linear representation
- Pattern-color separable spatial filtering
 - Not the same as spatial filtering in other color spaces such as $L^*a^*b^*$, YIQ, YCbCr.

Retinal
Ganglion Cells
Project In An
Organized
Fashion to
The Lateral
Geniculate
Nucleus;
Signals Are
Then Sent To
Primary Visual
Cortex



The Lateral Geniculate Nucleus Layers Receive Inputs From Different Ganglion Cell Types; The Responses in These Layers Mirror The Retinal Organization; The LGN Signals Are Transmitted to Distinct Cortical Layers

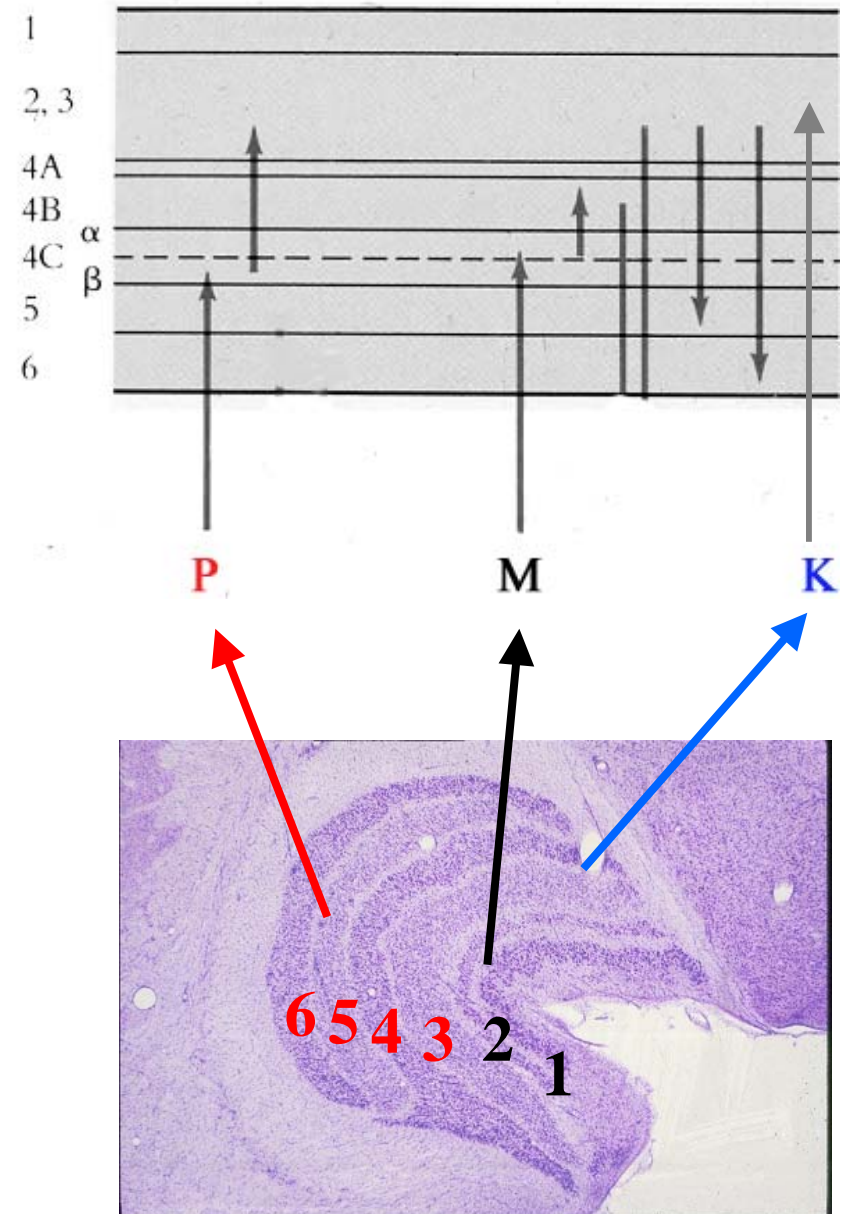

Human Brain By The Numbers

(Braitenberg and Schutz, 1991)

Neurons are the computational elements

White matter connects the neurons via axons

The connection is called the synapse

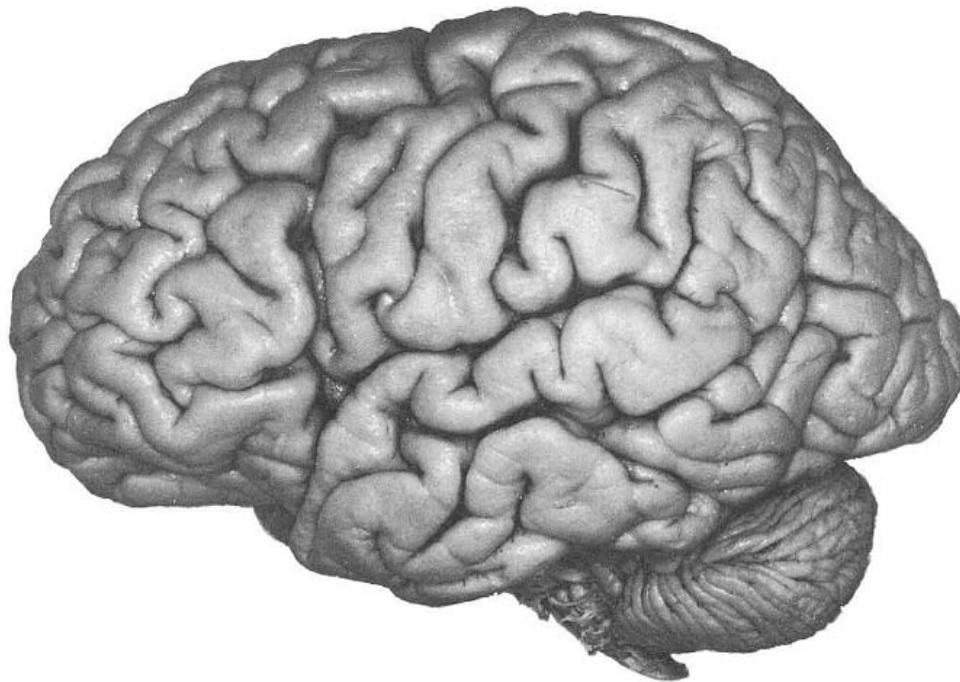

- Neurons: 10^{11}
- Synapses: 10^{14}
- Synapses/neuron 10^3
- Surface area of each hemisphere: $25 \times 30 \text{ cm}^2$
- Most connections are local (10-100 μm); some span many cm
- Neurons/ mm^3 : 10^4 - 10^6
- Axon length/ mm^3 : 3 km

Magnetic Resonance Scanners Can Be Used To Measure Brain Activity

(Wandell, 1999)

Functional MRI

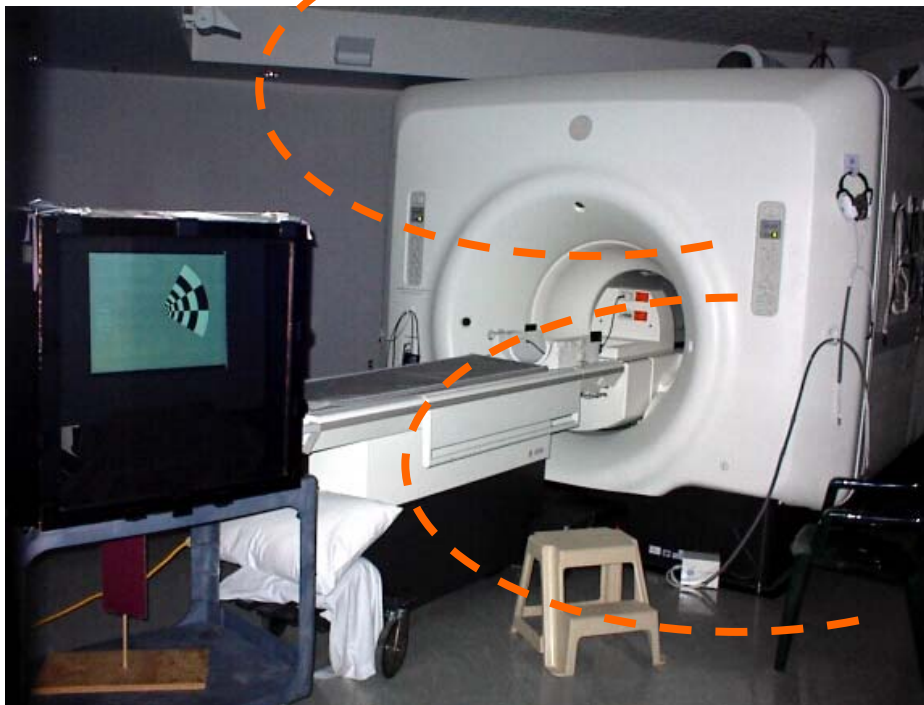

- Non-invasive
- Measures intrinsic signal (dipole relaxation)
- Spatial resolution ~ 2 mm
- Temporal resolution ~ 5 sec
- Can study individual subjects in detail

The fMRI Signal Is Based On Measurements Of Hydrogen Atoms Bound to Water

T2 Relaxation

Transverse magnetization of dipoles

RF pulse

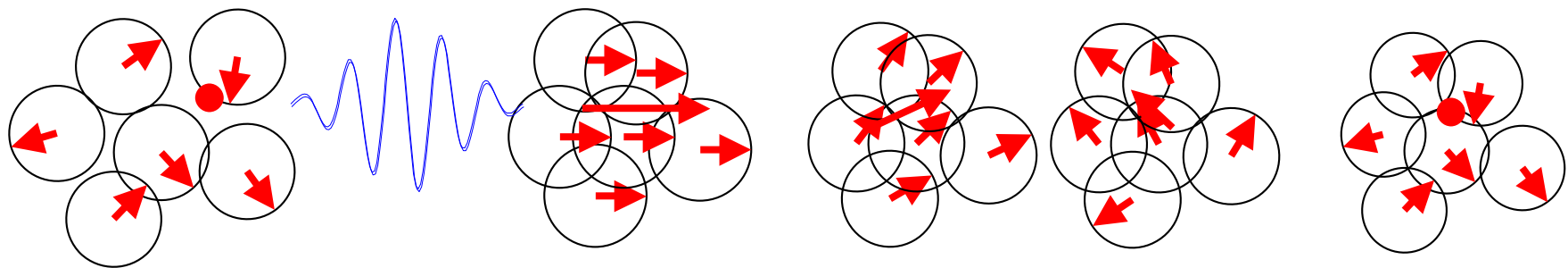

Time

200 ms

There Is An Increase In Oxygenated Blood Flow To Active Regions of Cortex

J.F. Fulton, M.D. (1928)

- *Subject noted that ‘the noise in the back of his head increased in intensity when he was using his eyes.’*
- *No increase for hearing, touch or smell*
- *Increased more when he tried harder*

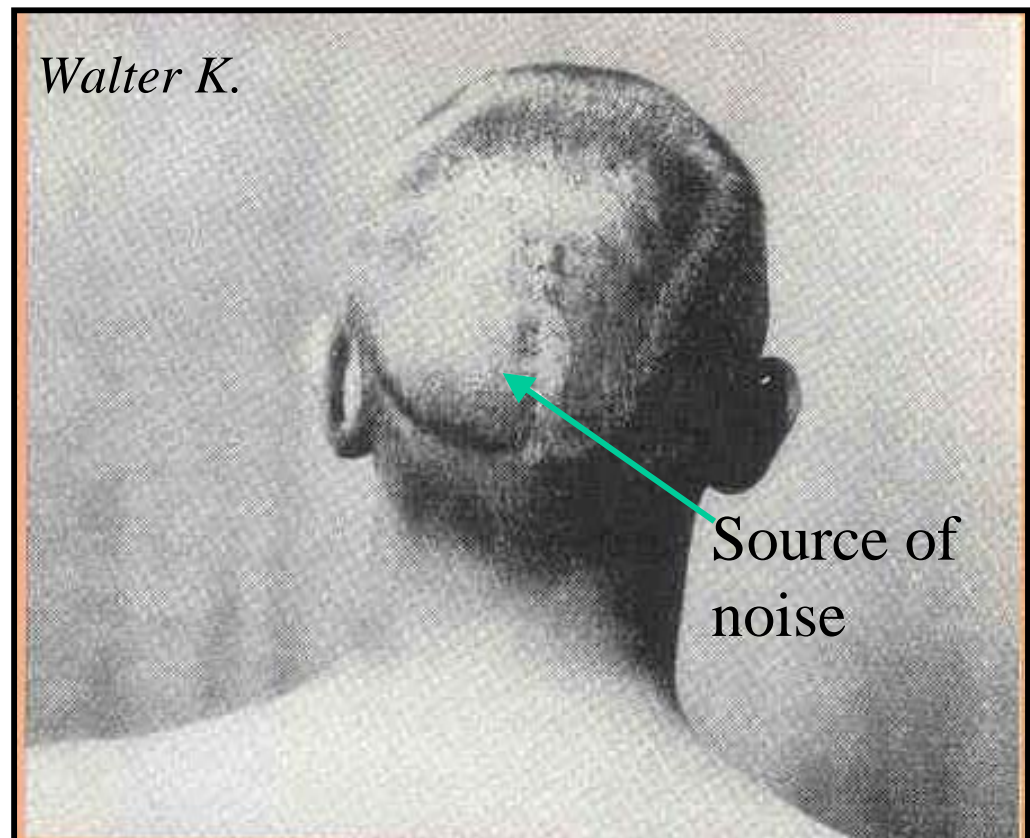

The fMRI Signal Measures Blood Oxygenation

Control state

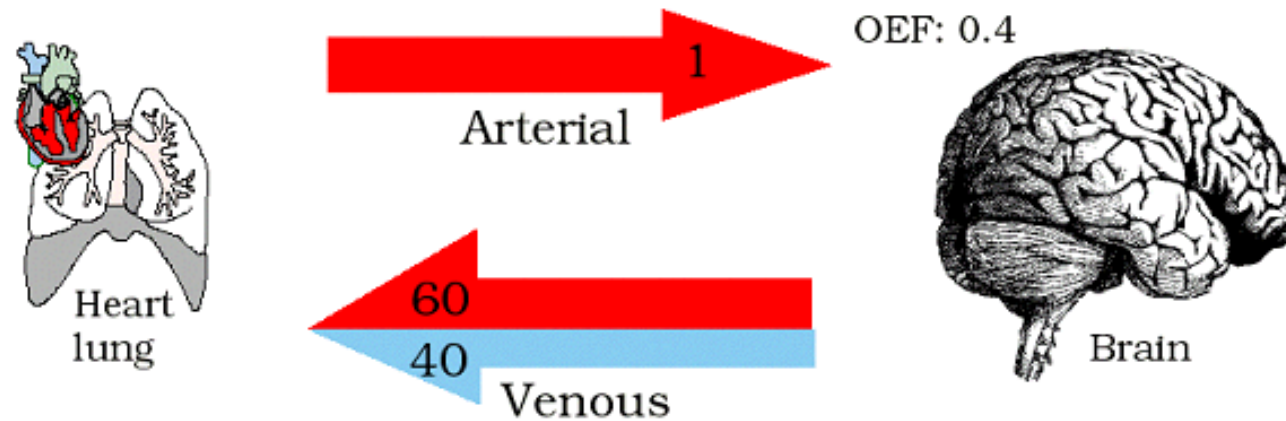

Active state

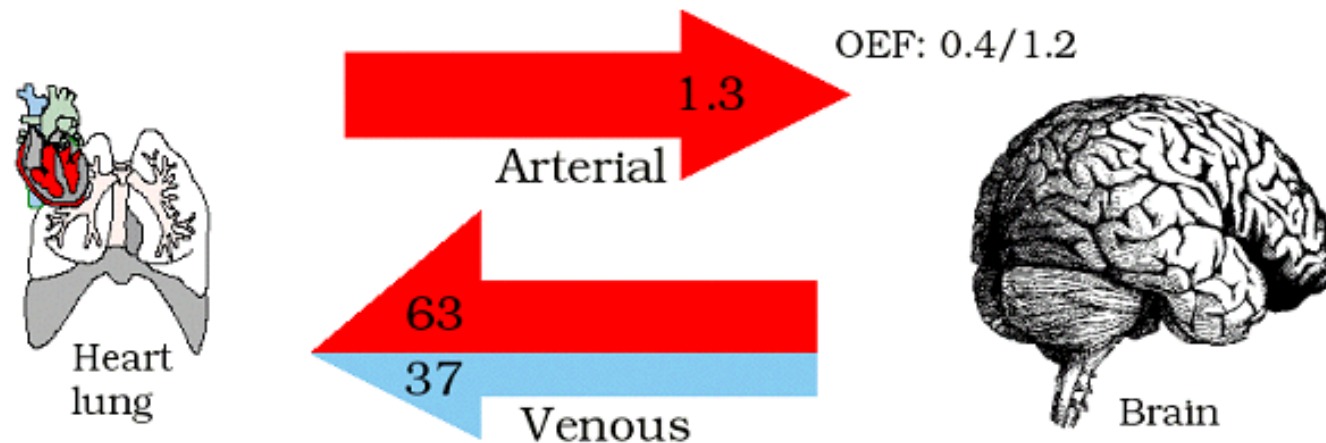

Cortex Contains Multiple Visual Maps That Can Be Measured Using fMRI in Human and Macaque

(Brewer, Press, Logothetis, Wandell)

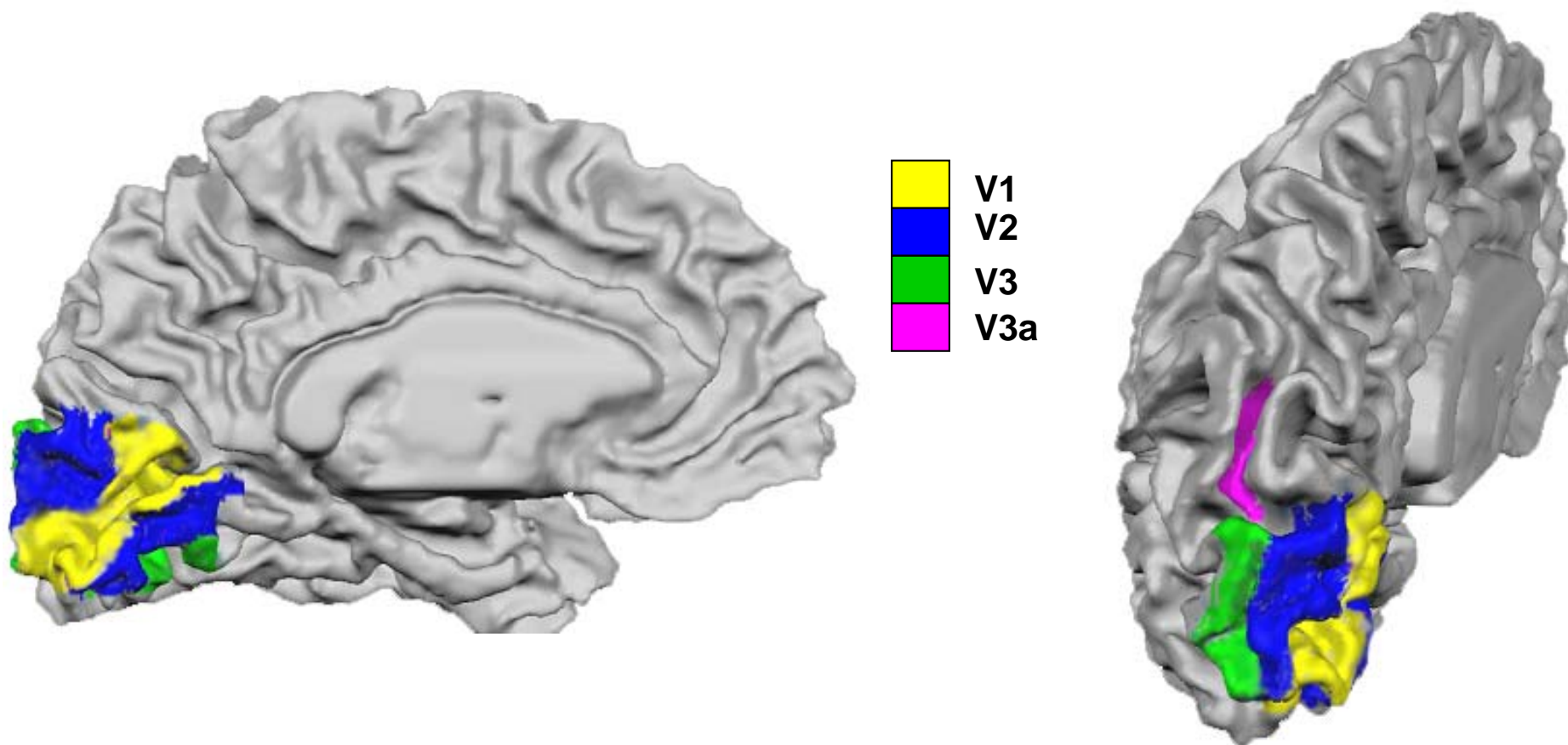

Color Responsivity in V1 Is Similar To Behavioral Sensitivity

(Engel, Zhang, Wandell, 1997)

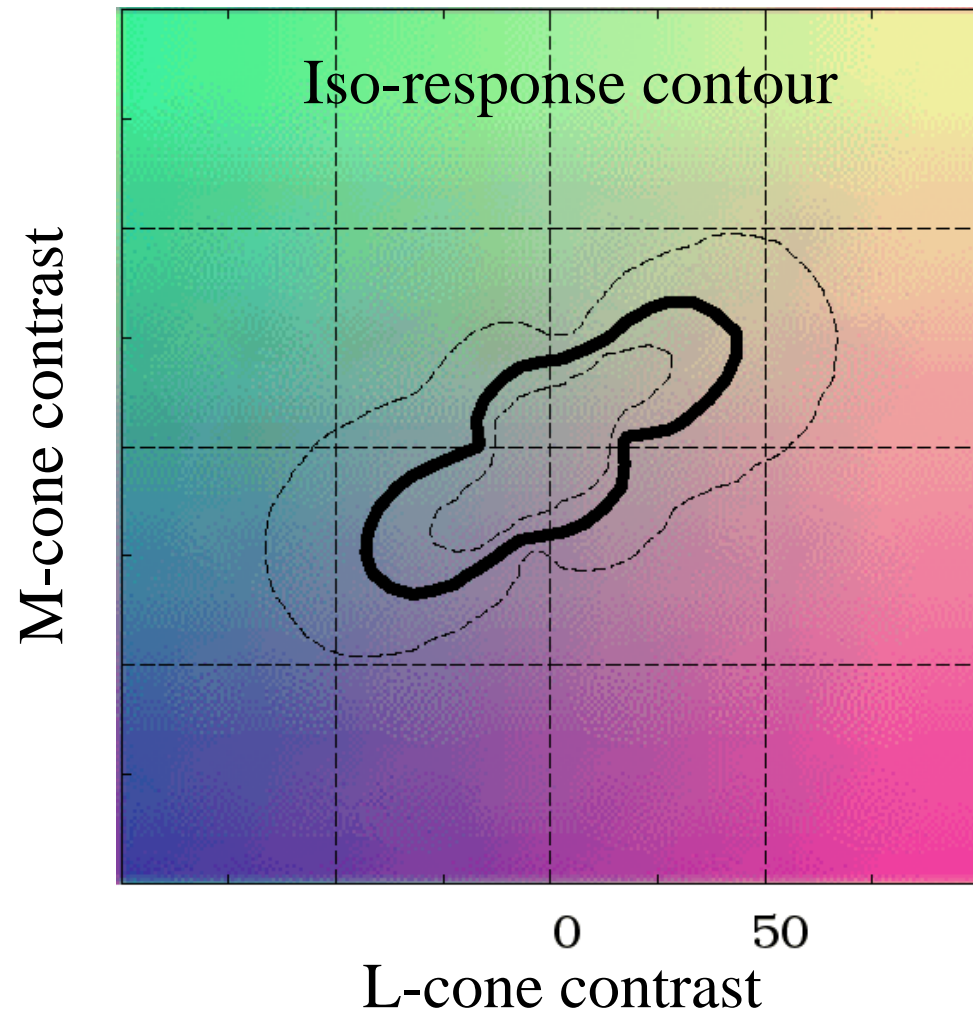
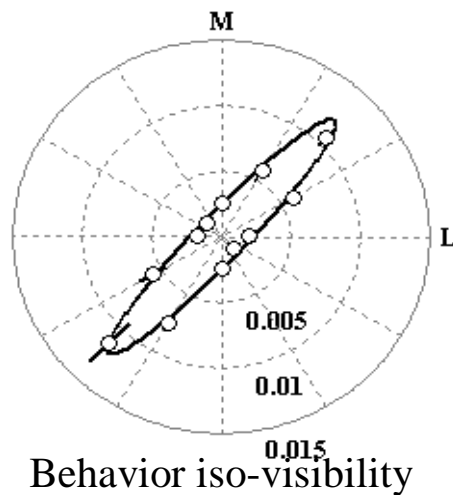

Color Responses Exceed Achromatic Responses Primarily In Ventral Occipital Cortex

(Wade, Brewer, Rieger, Wandell, 2002)

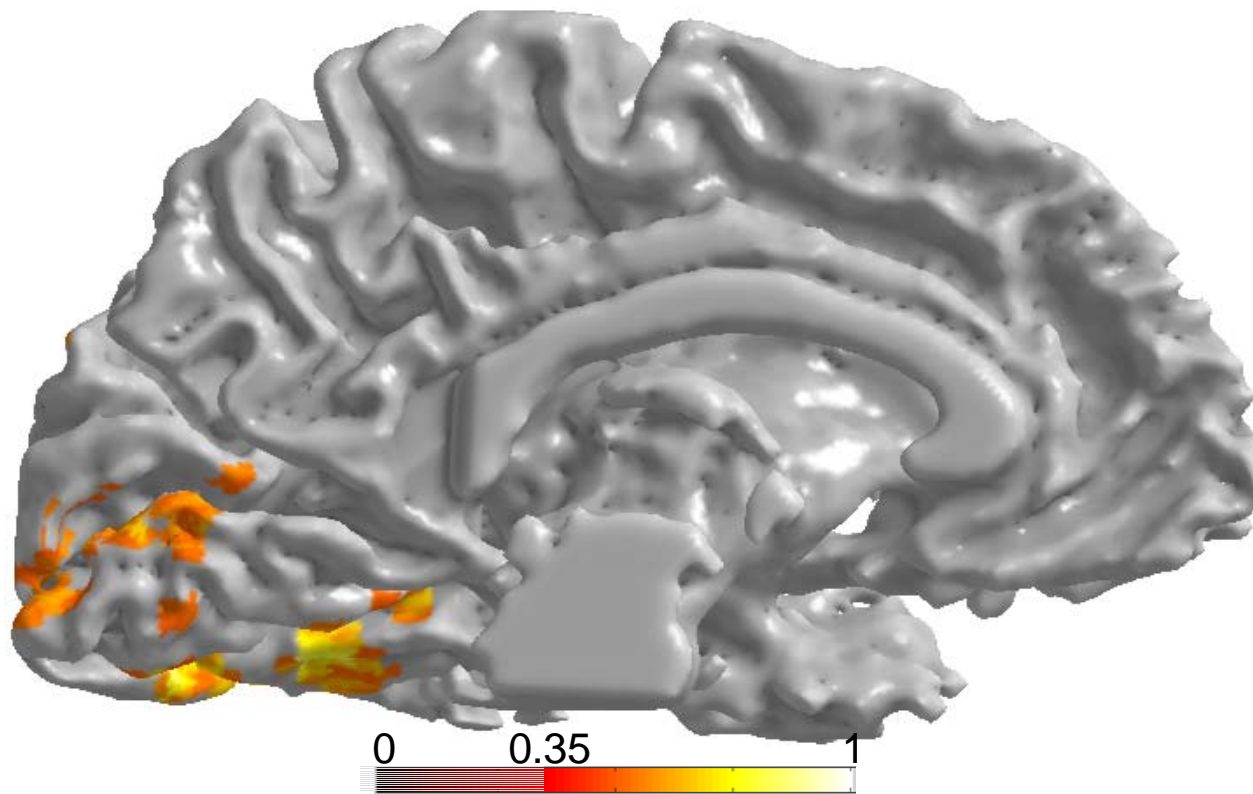

Human Ventral
Occipital
Cortex, Near
hV4, Responds
Powerfully to
Color Signals;
Damage Can
Cause A
Hemifield Loss
of Color
Perception

Ventral Surface Human Brain

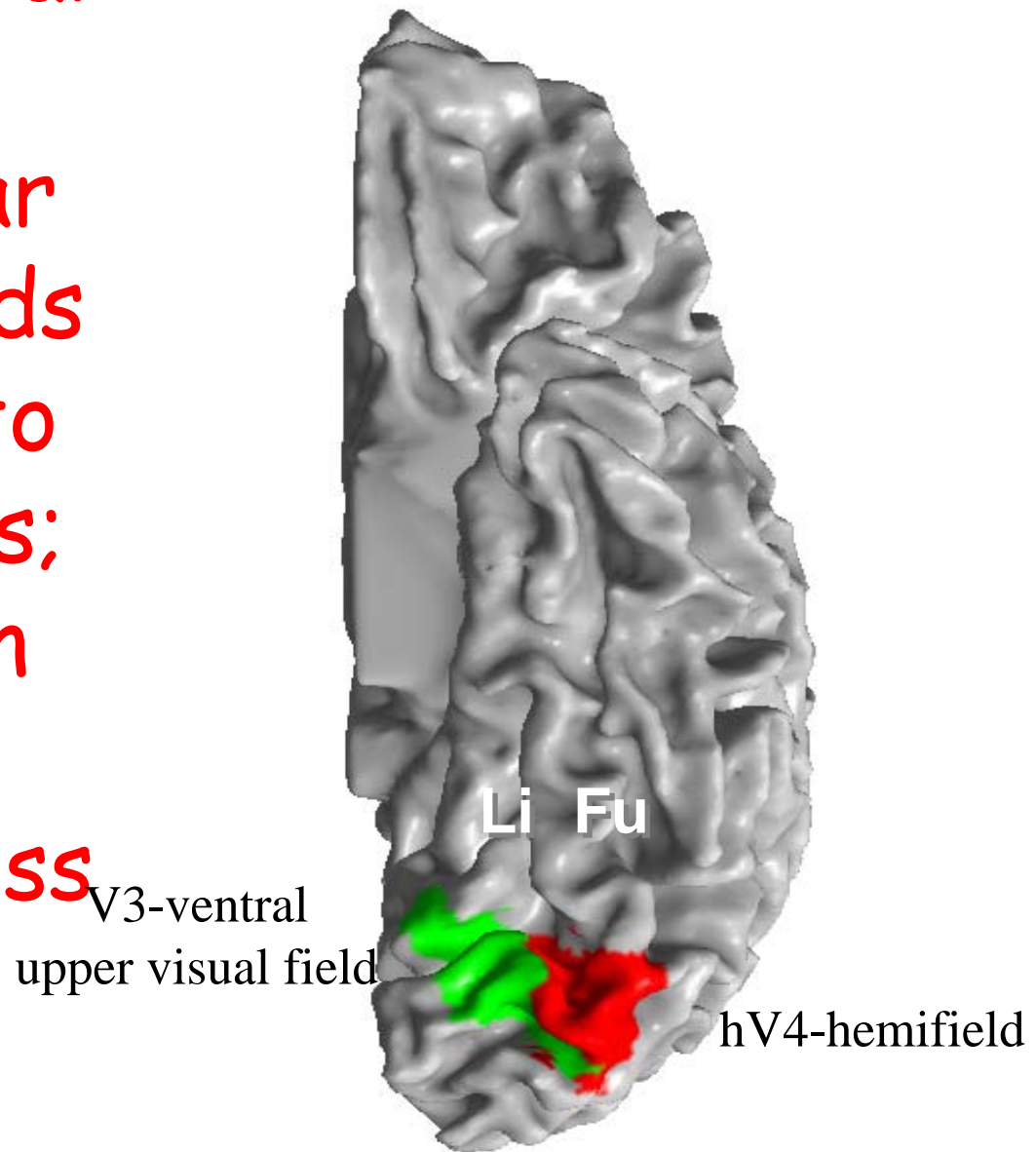

Variations in
Illumination
Change The
Light
Scattered
To Our Eyes
From An
Object

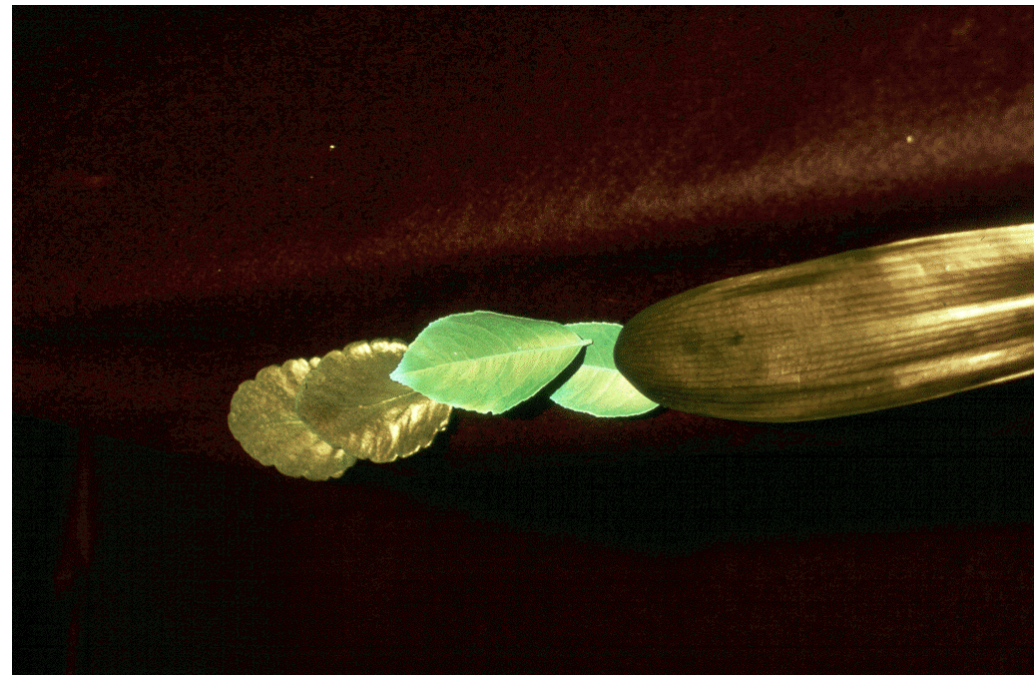

© 2002

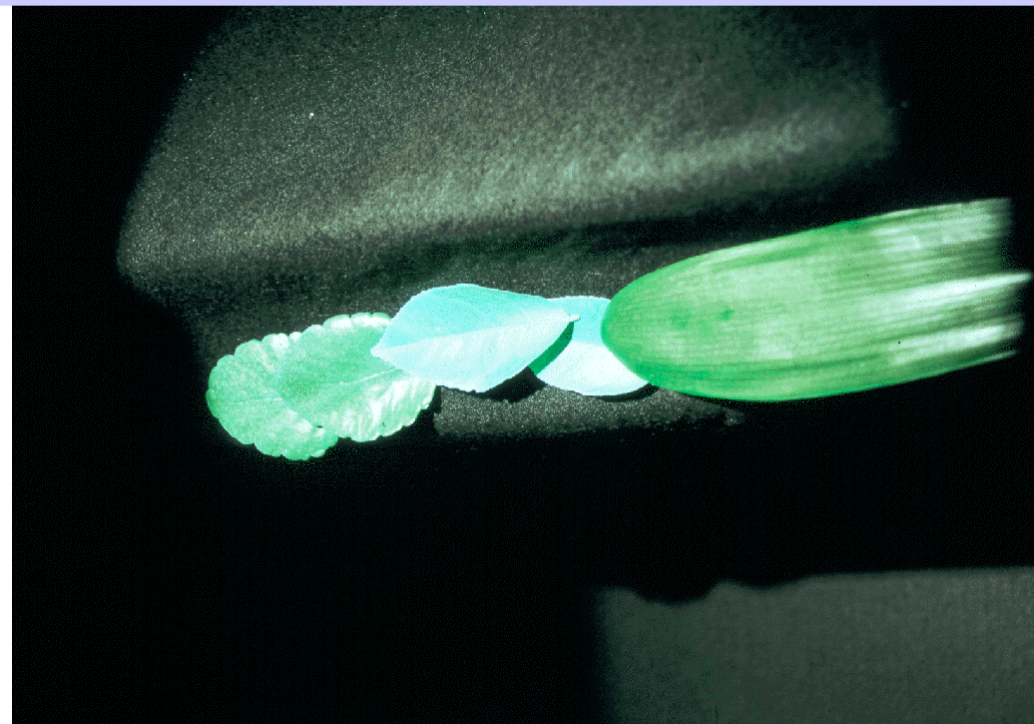

Courtesy S. Tominaga

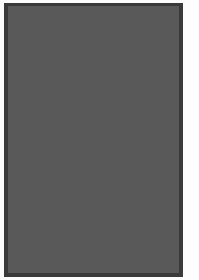
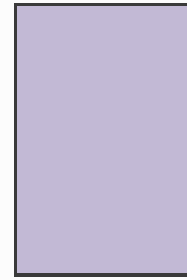
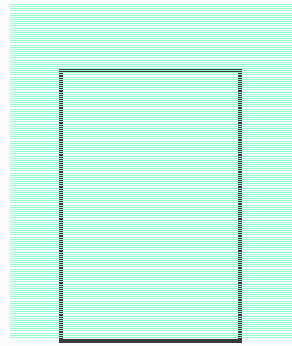
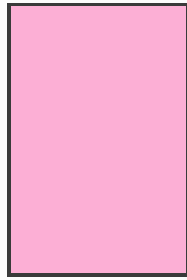
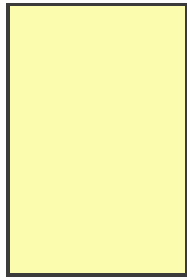
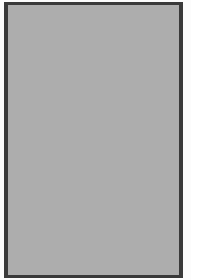
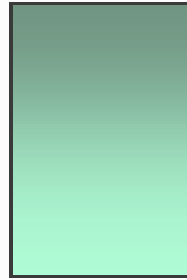
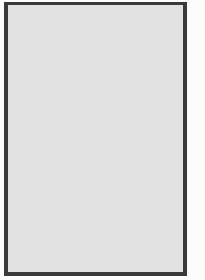
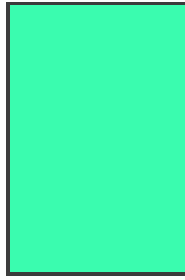
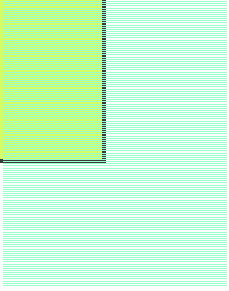
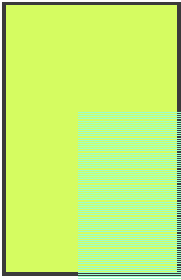

*Color Appearance is
Calculated Across Space*

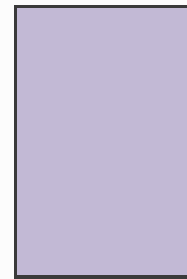
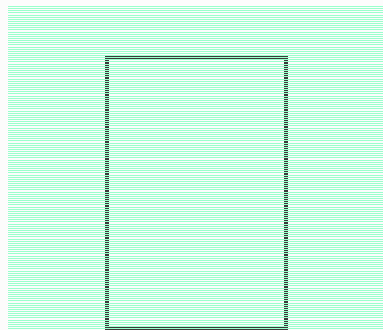
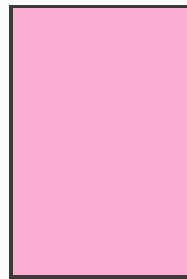
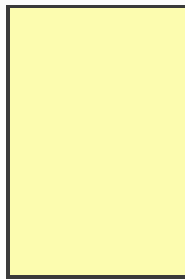
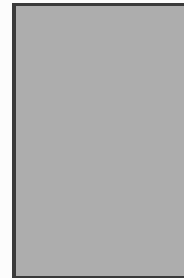
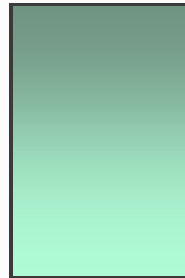
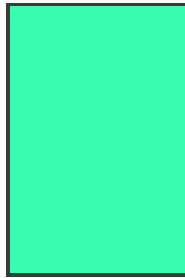
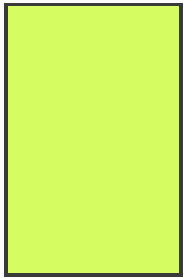



Demonstration of Adaptation



It Is Desirable To Associate Color Appearance With The Surface Scattering, Not The Reflected Light

Illuminant 1



Illuminant 2



Appearance

Color balancing solutions

Two components.

1. Make an estimate of the spectral composition of the illumination.
2. Use a method to transform the acquired data into appropriate display values.

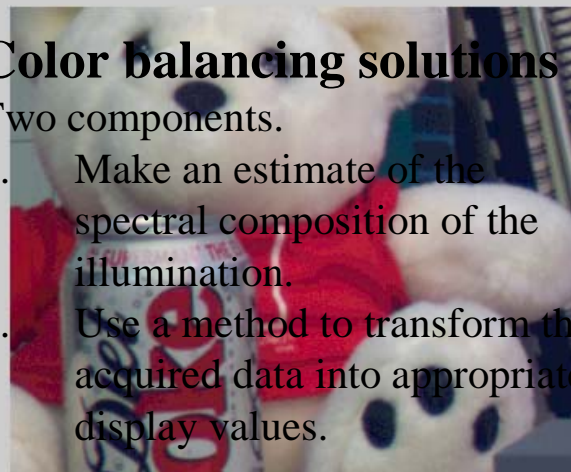

If Color Balancing Fails, The Appearance Can Be Very Wrong

Unknown

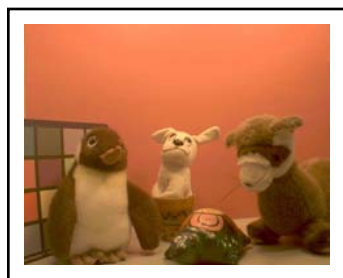

Camera responses

Transform 1

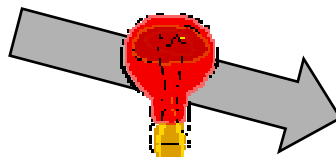
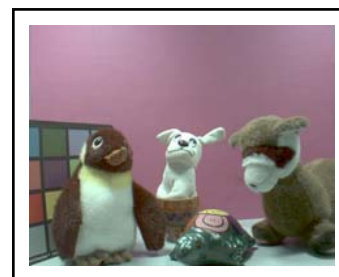
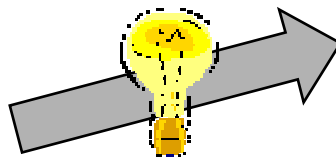

Transform 2

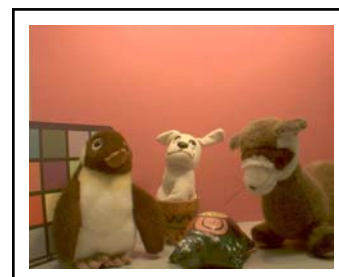

Transformed responses

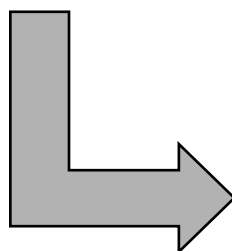

Estimate



Ambient illuminant

Best Information About the Illumination Is In Light Regions

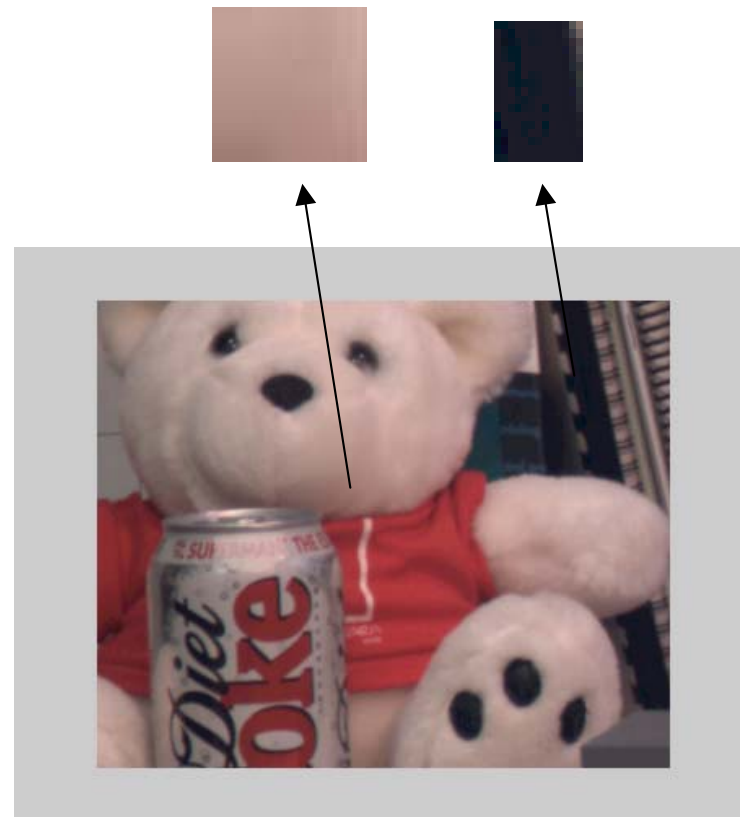
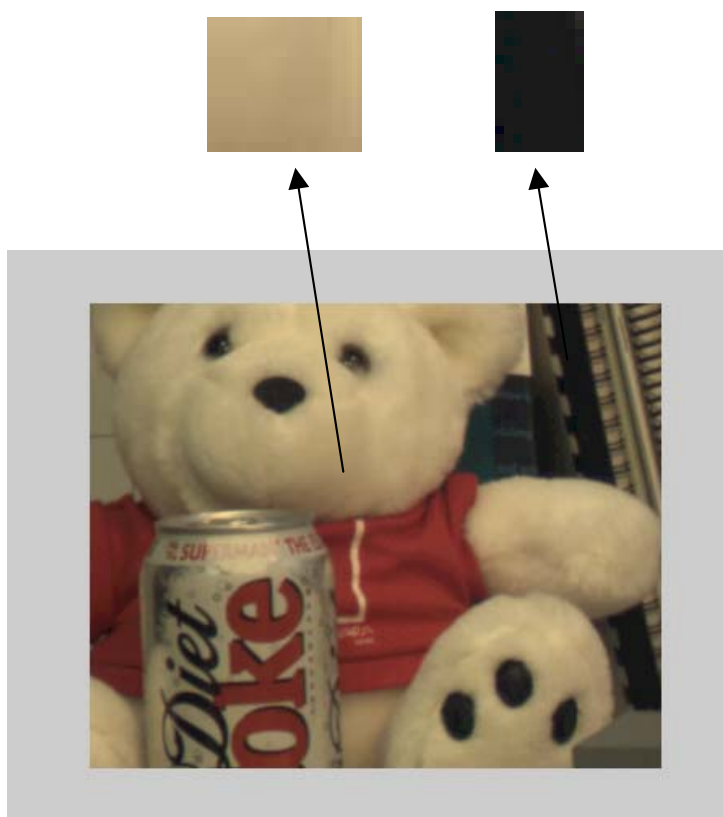

Various Methods Have Been Used To Measure Adaptation In People

Chichilnisky and Wandell

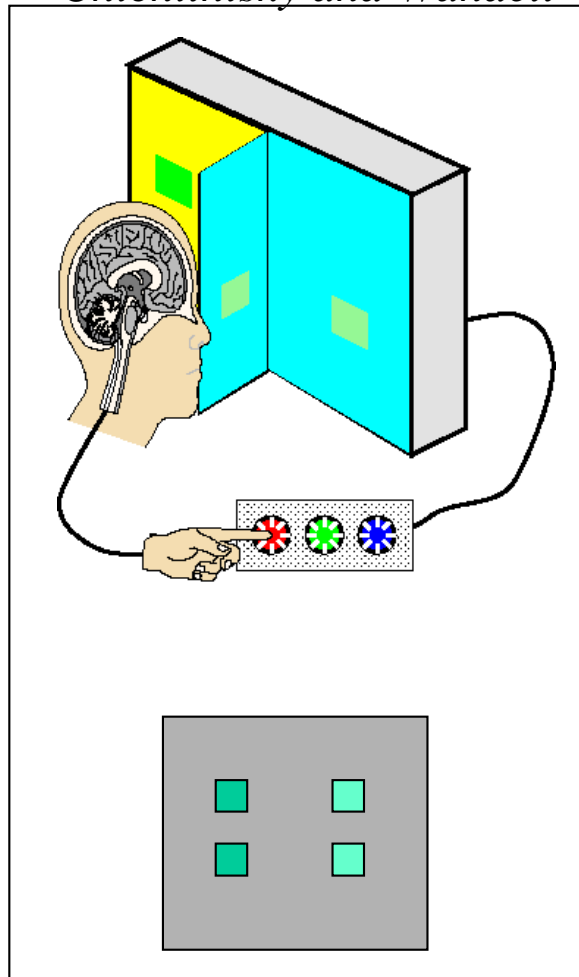

Kraft and Brainard

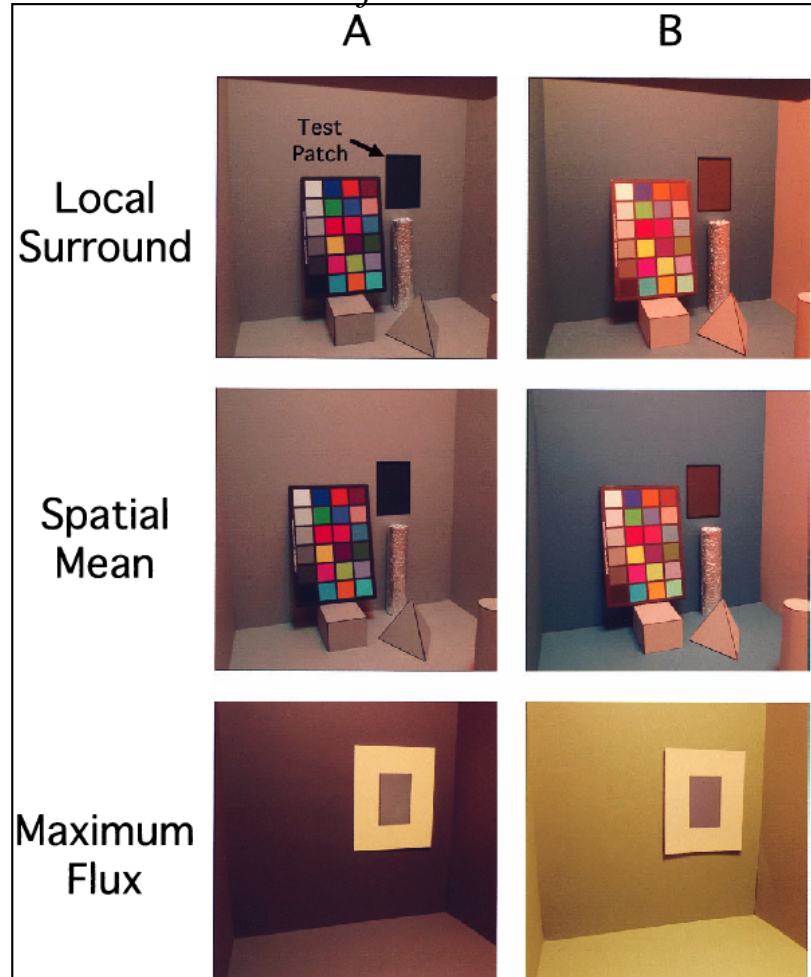

*He, Makous, MacLeod
Bauml
Fairchild and Berns
Delahunt and Brainard
...
Many others*

Dichoptic Color
Matching Data
Support A
Simple Gain
Control Model
As a 1st
Approximation

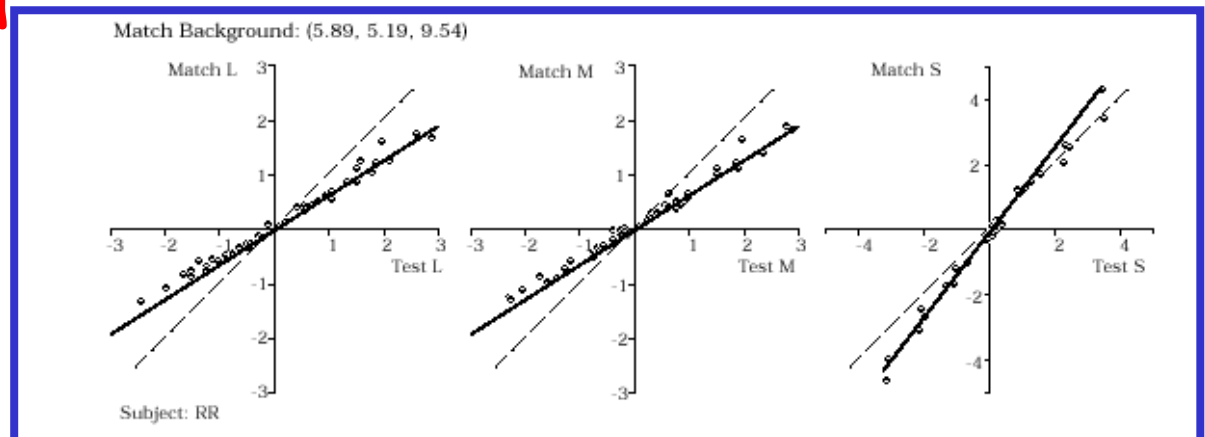
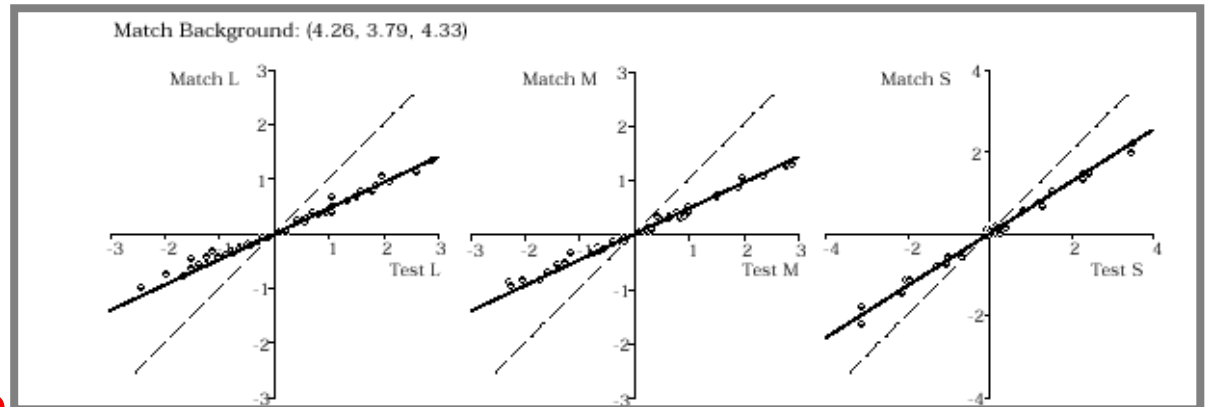
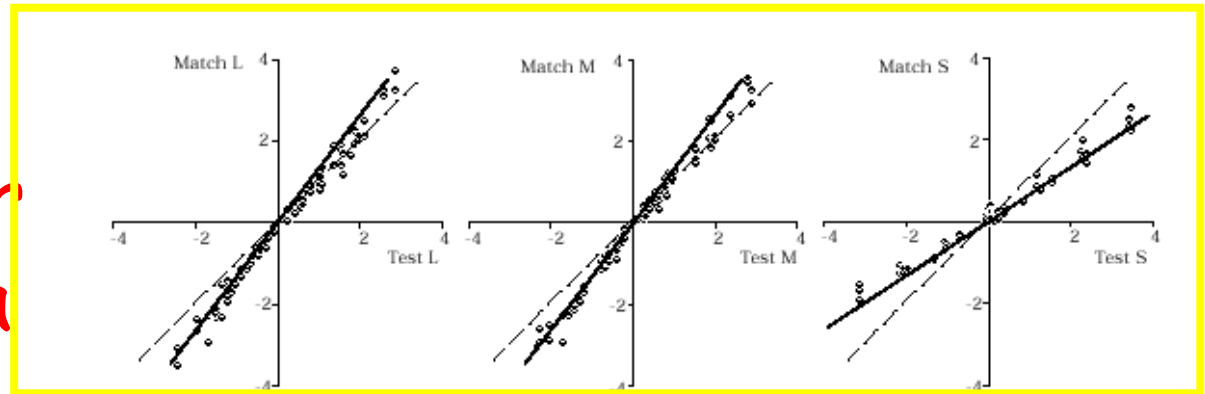

The Gain Control Model Is Also Called von Kries Adaptation And Can Be Expressed In Simple Mathematical Form

Match context

Test context

$$\begin{pmatrix} \Delta L' \\ \Delta M' \\ \Delta S' \end{pmatrix} = \begin{pmatrix} G_L(T, M) & 0 & 0 \\ 0 & G_M(T, M) & 0 \\ 0 & 0 & G_S(T, M) \end{pmatrix} \begin{pmatrix} \Delta L \\ \Delta M \\ \Delta S \end{pmatrix}$$

*Where G is the receptor gain. Its value depends on the properties of the **T**est and **M**atch contexts*

Von Kries Adaptation Still Leaves Unanswered Questions About How The Gain Is Set

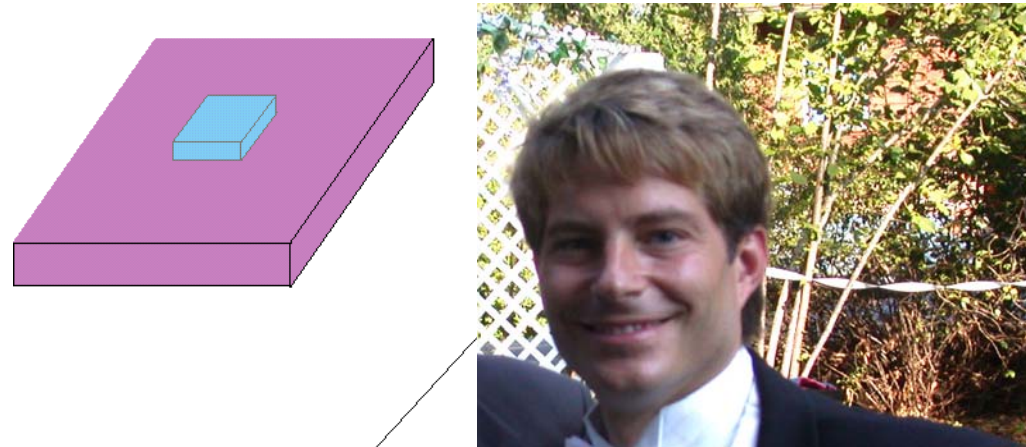

What determines the scale factors?

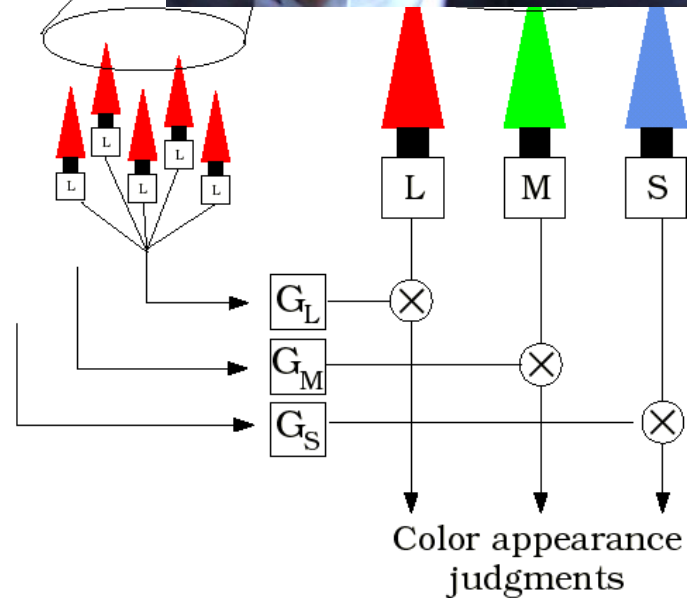

It Is Possible To Measure Color Sensitivity Changes In Human Cortex

(Wade and Wandell, 2002)

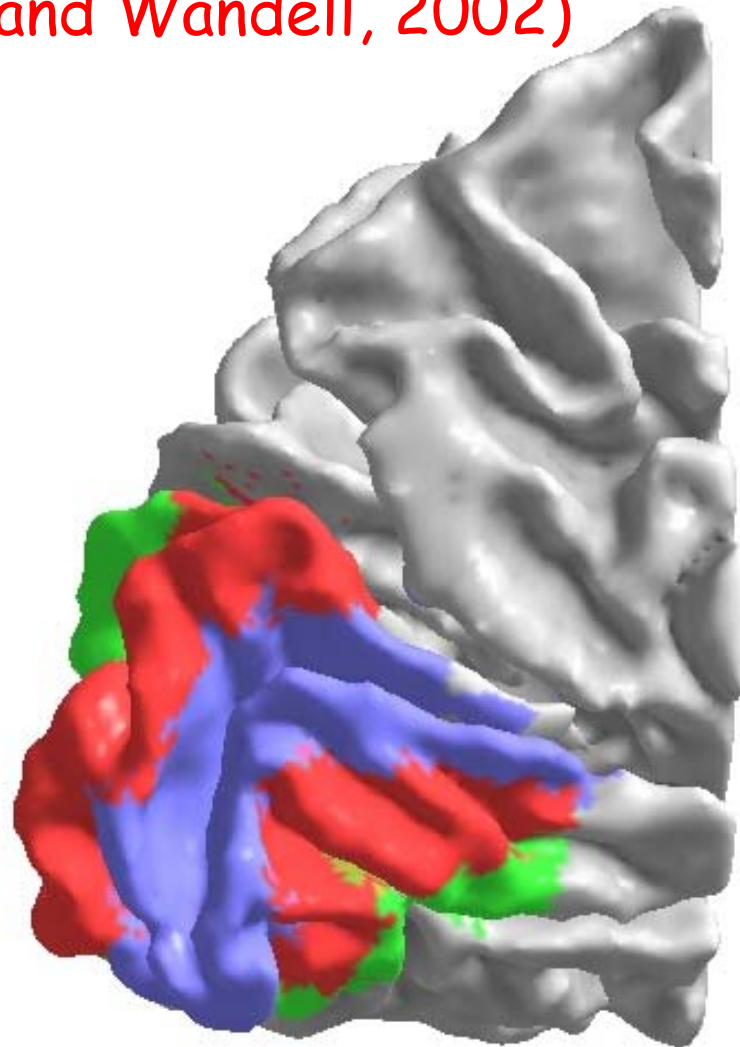
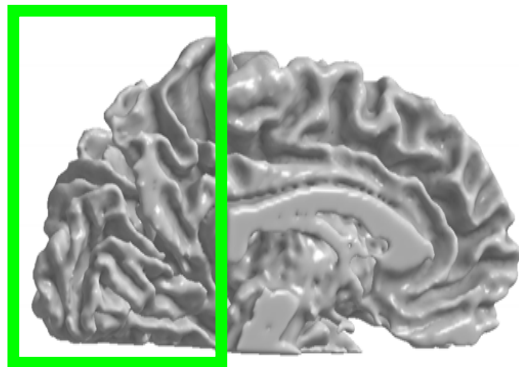

Visual area

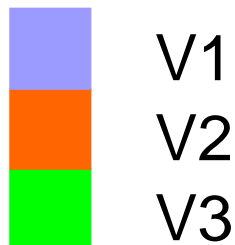

An FMRI Paradigm Used To Measure Gain Control

- Block design
- Test Probe:
 - Low contrast dartboard
 - Flickering at 2Hz
 - Constant amplitude (small)
 - S-cone or L,M-cone probes
 - Background
 - Large (30 deg diameter)
 - Changing very slowly
 - S-cone or L,M-cone change

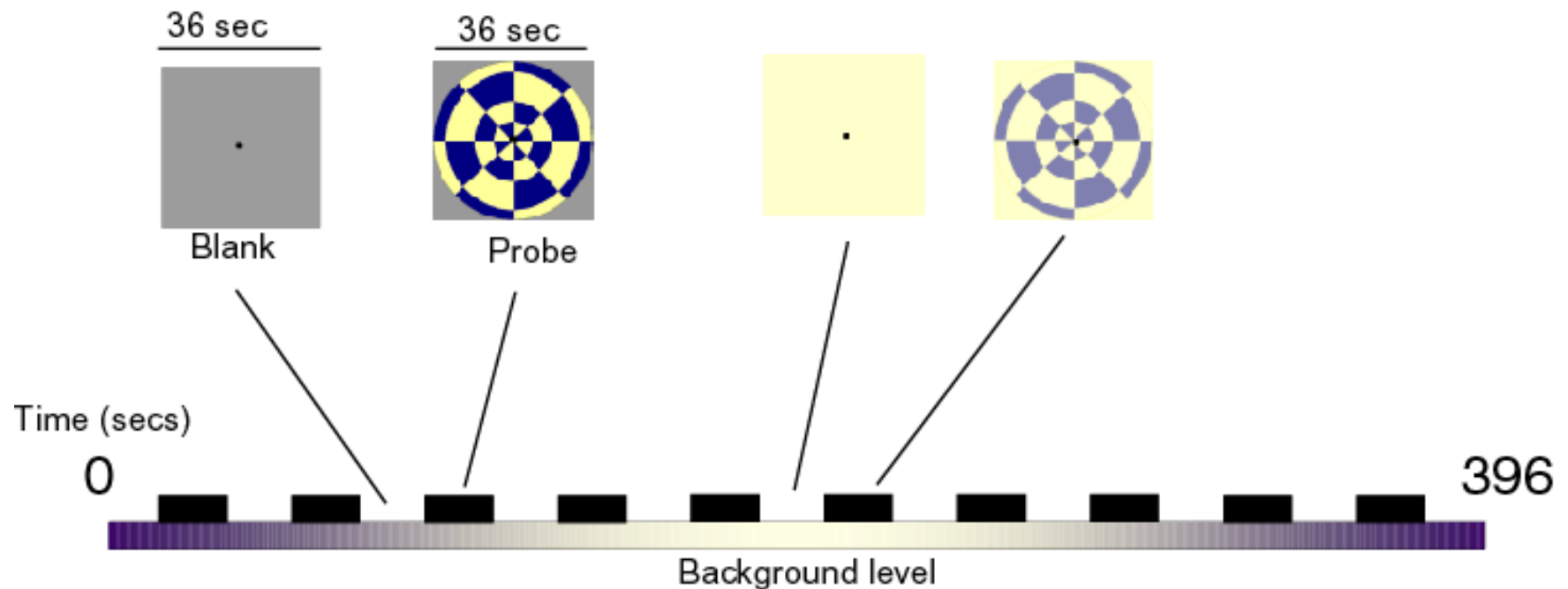

Changes In
Sensitivity
Can Be
Measured in
the fMRI
Time Series
And
Compared
With
Behavior

Probe

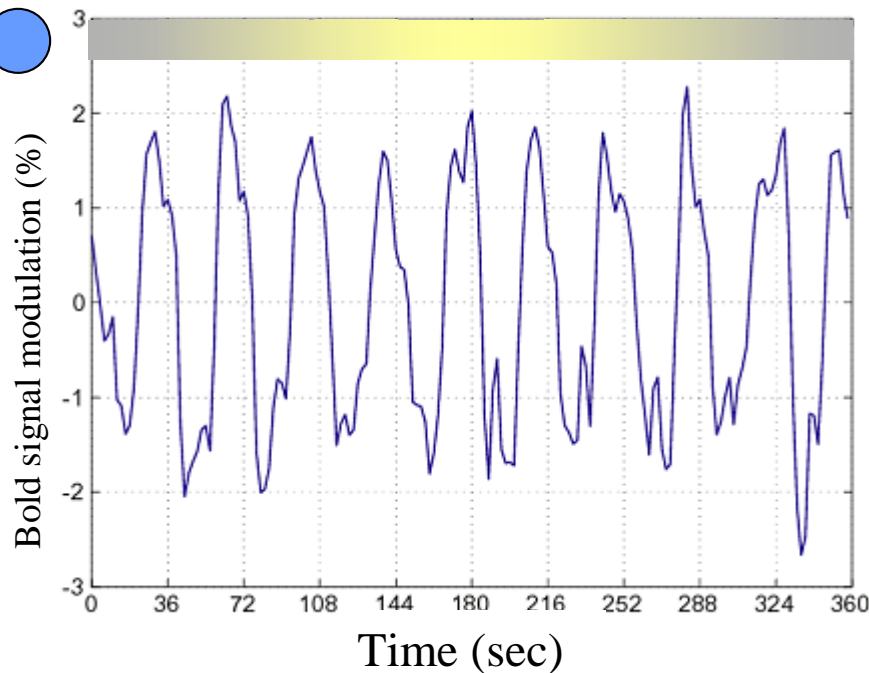
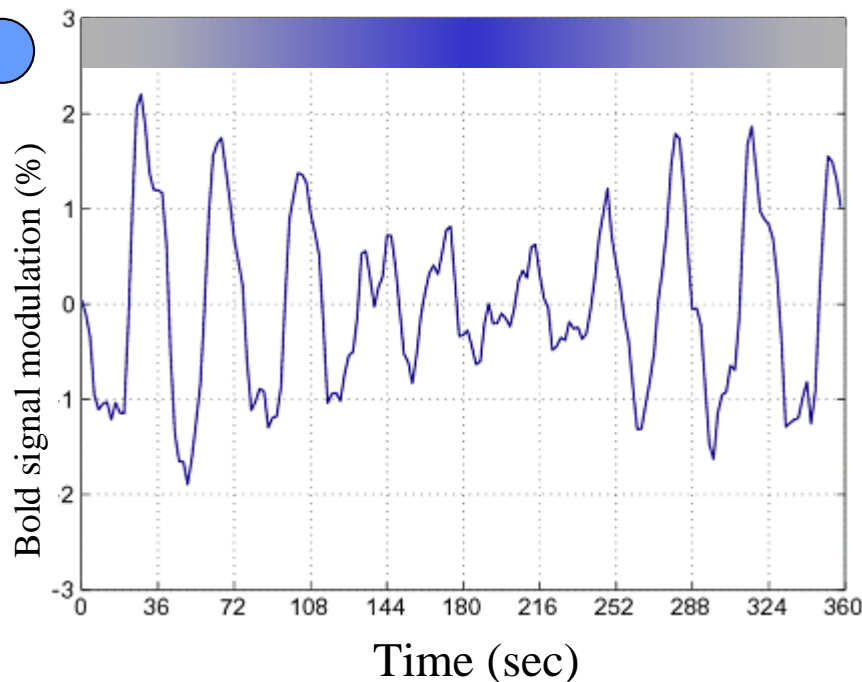

Tutorial Outline

- Introduction: Appearance and Computation
- Wavelength encoding and the photoreceptors
- Spatiotemporal sensitivity and the retina
- Color coding and visual cortex
- Visual Adaptation

Suggested Readings and Reference Volumes

Vision Science

Foundations of Vision (B. A. Wandell)

The First Steps in Seeing (R.W. Rodieck)

A Vision of the Brain (S. Zeki)

Eye, Brain and Vision (D. Hubel)

Color vision : from genes to perception (Ed. Gegenfurtner and Sharpe)

Color Science and Engineering

Color science : concepts and methods, quantitative data and formulae (Wyszecki and Stiles)

Color in business, science, and industry (Deane B.Judd and Guenter Wyszecki)

Principles of Color Technology (Berns, Billmeyer and Saltzman)

Reproduction of Colour (R.W.G. Hunt)

Perception

Goldstein's Sensation and Perception

Neuroscience

The astonishing hypothesis : the scientific search for the soul (Francis Crick)

The New cognitive neurosciences (Ed. Michael S. Gazzaniga)

The Human Components of Image Systems

Brian Wandell
Psychology and EE
Stanford University

Web-sites

www.imageval.com

www.vischeck.com

white.stanford.edu



*Many of the images in this tutorial are from
Wandell, Foundations of Vision, Sinauer Press*